

RISA-2D

Rapid Interactive Structural Analysis – 2-Dimensional

Tutorials



RISA Tech, Inc.

27442 Portola Pkwy, Suite 200

Foothill Ranch, California 92610

(949) 951-5815

(949) 951-5848 (FAX)

risa.com

Copyright © 2022, RISA Tech, Inc. All Rights Reserved. RISA is part of the [Nemetschek Group](#).

RISA, the RISA logo and RISA-2D are registered trademarks of RISA Tech, Inc. All other trademarks mentioned in this publication are the property of their respective owners.

No part of this publication may be reproduced or transmitted in any form or by any means, electronic or mechanical, including photocopying, recording, or otherwise, without the prior written permission of RISA Tech, Inc.

Every effort has been made to make this publication as complete and accurate as possible, but no warranty of fitness is implied. The concepts, methods, and examples presented in this publication are for illustrative and educational purposes only, and are not intended to be exhaustive or to apply to any particular engineering problem or design. The advice and strategies contained herein may not be suitable for your situation. You should consult with a professional where appropriate. RISA Tech, Inc. assumes no liability or responsibility to any person or company for direct or indirect damages resulting from the use of any information contained herein.

Table of Contents

Introduction	1
How to Use this Book.....	1
Document Conventions	2
Technical Support Information	4
Before You Begin	5
RISA-2D Overview	5
License Agreement	7
Installation	8
RISA-2D Customization–Important Assumption!	8
First Look at RISA-2D.....	9
Starting RISA-2D	9
Windows and Dialog Boxes.....	9
Menus and Toolbars	11
Managing Windows, Model Views, and Spreadsheets.....	15
Tutorial 1 – Modeling.....	17
Overview	17
Starting a New File	18
(Global) Model Settings	19
Members.....	23
Material Properties.....	34
Design Rules – Size/UC.....	36
Section Sets Spreadsheet.....	39
Multiple Windows.....	48
Entering Spreadsheet Data	51
Boundary Conditions.....	55
Tutorial 2 – Modifying.....	59
Overview	59
Modifying an Item.....	60
Editing the Model View.....	62
Model Display Options.....	64
Selection Tools	65
Modify Members	68
Model Merge	71
Modify Members	79
Wall Panels.....	83

Tutorial 3 – Loading	93
Overview	93
Load Cases, Categories, and Combinations	94
Joint Loads	95
Distributed Loads	97
Basic Load Case Spreadsheet	99
Self-weight	102
Load Combinations	103
Displaying Loads.....	111
Tutorial 4 – Solving & Results	113
Overview	113
Solve the Model	114
Graphic Results	116
Deflected Shapes	117
Color-Coding Member Results	119
Member Detail Report	121
Printing Graphic Results.....	123
Code Check Results	125
Optimizing Member Sizes	127
Printing Results and Spreadsheets	129
Appendix A – RISA-2D Toolbar Button Quick Reference	133
RISA Toolbar.....	133
Window Toolbar	135
Drawing Toolbar.....	139
Selection Toolbar	141

Introduction

How to Use this Book

Welcome to the *RISA-2D User's Guide*. If you are a first-time user of RISA-2D, we recommend that you start with this book. This book contains step-by-step tutorials that guide you through the entire modeling process using most RISA-2D features. You will create a real-world example of building and solving a model, making changes, and optimizing the model. Several tips and shortcuts will also be demonstrated along the way.

Begin by reviewing [First Look at RISA-2D](#) on page 9 to familiarize yourself with the RISA-2D menus, toolbars, and shortcuts. Then proceed to the step-by-step tutorials. There is also a handy reference included as *Appendix A – RISA-2D Toolbar Button Quick Reference* to help you reference toolbar buttons.

To complete all the tutorials will take only a few hours. However, you can speed up the process even further if you skip the supporting text and concentrate only on the action steps, which are indicated with diamond-shaped bullets, as shown below:

- ◆ In order for you to achieve accurate results, it is important that you do not miss any of these action steps while performing the tutorials.

The tutorials build upon themselves from start to finish. You have the option of performing them all at one time, or performing each one separately. To make this possible, RISA provides model files for you to load at the beginning of each tutorial. These starter files are located in the RISA folder under Tutorials, and are named RISA-2D Tutorial 2 Starter.r2d, RISA-2D Tutorial 3 Starter.r2d, etc.

After you have completed the tutorials in this guide, you can use the Help Menu and *RISA-2D General Reference* for complete, detailed information on every topic relating to RISA-2D. The topics are thoroughly indexed for quick reference.

If you are a more experienced user and are not sure which book will be most helpful for your situation, consider that the *RISA-2D User's Guide* covers how and when to apply RISA-2D features such as wall panels, but the specifics of how those wall panels are designed are covered in the Help Menu and the *RISA-2D General Reference*.

Where to Download RISA-2D Book Updates

Every effort has been made to ensure the accuracy of this book at the time of publication. The latest edition of all books and documents relating to this product are available in Adobe PDF format at <http://www.risa.com>. Click **Downloads**, **Product Documentation**, then **RISA-2D**.

Document Conventions

The following conventions are used throughout this book:

This convention: Indicates:

CAPITAL LETTERS Names of keys on the keyboard – for example, SHIFT, CTRL, or ALT.

KEY+KEY One key should be held down and then another key pressed – for example, CTRL+P or ALT+F4.

Italic text New terms, other publications, and variable expressions – for example, *filename.txt*.

Bold text User interface options – for example, **File** menu.

Boxed text Notes or modeling tip information.



Tutorial action item for building the model.

Using the Online Help

Whether you need help on general topics, specific features, or toolbars, it is all built in to the extensive RISA-2D online Help system. The RISA-2D Help was designed to enable you to pinpoint the Help information you need quickly, by offering different ways for you to access and locate that Help, as described below:

Help on general topics

On the RISA toolbar, click the **Help** button . This is the fastest way to get help on general topics. You can also go to the main menu and click **Help**, then select **Help Topics**.

Once you enter the Help, notice the three tabs on the left: **Contents**, **Index**, and **Search**. You can explore the Help by topic using either Contents or Index, or use Search to explore the Help with your own specific keywords.

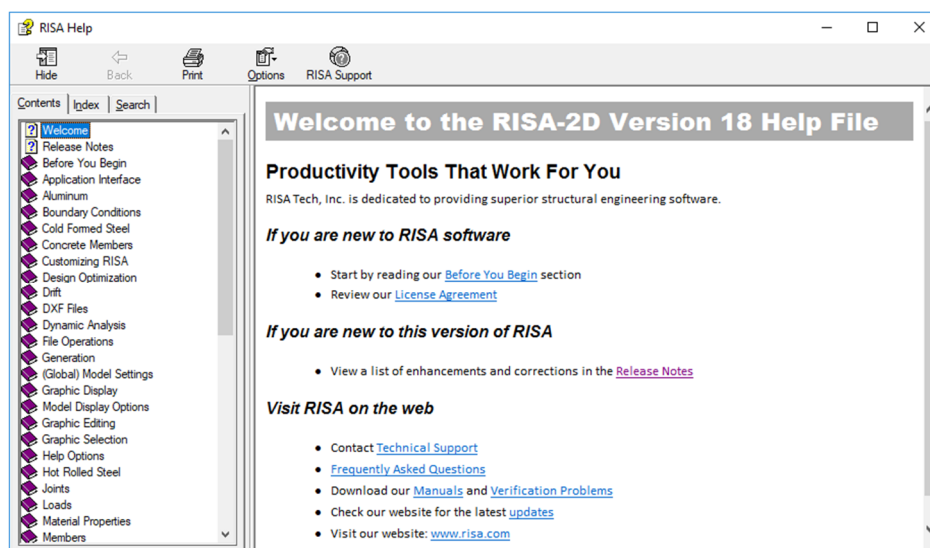

Help on a specific feature (context-sensitive help)

As you work, notice the **Help** buttons at the bottom of many of the dialog boxes. These provide direct access to the Help information related to the task you are performing.

This context-sensitive help may be accessed by pressing the **Help** button on the dialog box or by pressing the F1 key.

Help on toolbar buttons

Are you uncertain what a toolbar button is for? Simply hold your mouse pointer over that button (without clicking), and a description of that button will be displayed.

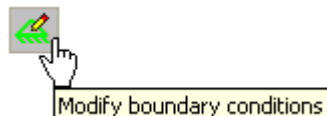

Technical Support Information

Technical support is an integral part of the software packages offered by RISA Technologies, and is available to all registered licensees at no additional charge. Our knowledgeable support team is ready to answer your most challenging questions.

Before contacting technical support, you may want to take a few minutes to do the following:

- Search the Help and all user documentation available for the product.
- Search our FAQ database by visiting our website at <http://www.risa.com>. Click **Education**, then **Frequently Asked Questions**, then choose the product.

When you are ready to make a support request, please be prepared to send us your model, and include the following information:

- Your name, company name, and phone number;
- Product name and serial number or Key ID;
- A detailed problem description; and
- Your model (filename.r3d) as an e-mail attachment. If your model contains multiple members, plates, or load combinations, please specify which ones we should look at.

You can contact Technical Support by e-mail or phone as follows:

E-mail: support@risa.com

E-mail is usually the best way to communicate with us when sending a model. Please include all the information listed above.

Phone: (949) 951-5815 or (800) 332-RISA (7472)

Technical support personnel are available from 6:00 A.M. to 5:00 P.M. Pacific Standard Time, Monday through Friday.

RISA Technologies Online

Visit RISA Technologies online at <http://www.risa.com> for:

- Answers to frequently asked questions.
- Downloads of user documentation and tutorials.
- Software updates – Any known problems are posted on the website, along with possible work-around procedures and/or service releases to update your software.
- Software verification problems.

Before You Begin

RISA-2D Overview

RISA-2D was designed to accelerate the time it takes to perform structural design. Computer-aided structural design is typically a three step process: (1) define your model, (2) solve the model to obtain solution results, then (3) review those solution results to see how the model performed and determine if changes are needed. Usually, this cycle must be repeated several times before arriving at a final, optimized design.

One main reason RISA-2D is able to speed up the design process so successfully is because of its unique ability to define the model and make revisions both graphically (using the drawing tools) and numerically (using the customized spreadsheets).

In RISA-2D, these two methods of entering and editing data work seamlessly together. Everything designed or drawn graphically is automatically recorded in the spreadsheets (which may be viewed and edited at any time)—and everything entered in the spreadsheets may be viewed and edited graphically at any time. As you perform the step-by-step tutorials in this guide, you will be exploring both methods using the drawing tools and the spreadsheets.

Hardware Requirements

Minimum

- Any Windows compatible computer with a Pentium 3 Processor or better
- Windows XP/Vista/7/8.1/10
- 256MB of RAM
- 200MB of hard disk space
- Two or three button mouse
- USB port (required for Stand-Alone version or Network Host computer)

Recommended

- Windows 7/8.1/10
- 256MB of RAM
- 200MB of hard disk space
- Two button mouse with wheel

Program Limits

Joints	1,000
Members	1,000
Plates	1,000
Materials	500
Section Sets	500
Custom Wood Species	500
Basic Load Cases	1,000
Loads	10,000
Moving Loads	500
Load Combinations	5,000
Mode Shapes	2,000

Demonstration Version: While you can open and solve a larger model, the largest model that can be saved to disk with the demonstration version is limited to 20 Joints, 20 Members, 20 Plates and 1 wall panel.

Also, the Demonstration Version will automatically shut down if left open for 24 continuous hours.

License Agreement

END-USER LICENSE AGREEMENT FOR RISA TECHNOLOGIES, INC. SOFTWARE

The RISA-2D software product (SOFTWARE PRODUCT) includes computer software, the associated media, any printed materials, and any electronic documentation. By installing, copying or otherwise using the SOFTWARE PRODUCT, you agree to be bound by the terms of this agreement. If you do not agree with the terms of this agreement RISA Technologies, Inc. is unwilling to license the SOFTWARE PRODUCT to you. In such event you must delete any installations and destroy any copies of the SOFTWARE PRODUCT and return the SOFTWARE PRODUCT to RISA Technologies, Inc. within 60 days of purchase for a full refund.

Copyright © 2022 by RISA Tech, Inc. All rights reserved. RISA is part of the [Nemetschek Group](#). The SOFTWARE PRODUCT is protected by United States copyright laws and various international treaties. All rights not specifically granted under this agreement are reserved by RISA Tech, Inc. "RISA" as applied to structural engineering software is a registered trademark of RISA Tech, Inc.

1. SOFTWARE LICENSE. The SOFTWARE PRODUCT is licensed, not sold. All right, title and interest is and remains vested in RISA Technologies, Inc. You may not rent, lease, or lend the SOFTWARE PRODUCT. You are specifically granted a license to the use of this program on no more than one CPU at any given time. The Network Version of the SOFTWARE PRODUCT is licensed for simultaneous use on a certain maximum number of network stations that varies on a per license basis. As part of the license to use the SOFTWARE PRODUCT, the program user acknowledges the reading, understanding and acceptance of all terms of this agreement. The SOFTWARE PRODUCT may not be reviewed, compared or evaluated in any manner in any publication without expressed written consent of RISA Technologies, Inc. You may not disassemble, decompile, reverse engineer or modify in any way the SOFTWARE PRODUCT. If the SOFTWARE PRODUCT was purchased at a discounted price for educational purposes it may in no event be used for professional design purposes. The terms of this license agreement are binding in perpetuity.

2. DISCLAIMER. We intend that the information contained in the SOFTWARE PRODUCT be accurate and reliable, but it is entirely the responsibility of the program user to verify the accuracy and applicability of any results obtained from the SOFTWARE PRODUCT. The SOFTWARE PRODUCT is intended for use by professional engineers and architects who possess an understanding of structural mechanics. In no event will RISA Technologies, Inc. or its officers be liable to anyone for any damages, including any lost profits, lost savings or lost data. In no event will RISA Technologies, Inc. or its officers be liable for incidental, special, punitive or consequential damages or professional malpractice arising out of or in connection with the usage of the SOFTWARE PRODUCT, even if RISA Technologies, Inc. or its officers have been advised of or should be aware of the possibility of such damages. RISA TECHNOLOGIES' entire liability shall be limited to the purchase price of the SOFTWARE PRODUCT.

3. LIMITED WARRANTY. RISA Technologies, Inc. warrants that the SOFTWARE PRODUCT will operate but does not warrant that the SOFTWARE PRODUCT will operate error free or without interruption. RISA Technologies sole obligation and your exclusive remedy under this warranty will be to receive software support from RISA Technologies via telephone, email or fax. RISA Technologies shall only be obligated to provide support for the most recent version of the SOFTWARE PRODUCT. If your version of the SOFTWARE PRODUCT is not the most recent version RISA Technologies shall have no obligation to provide support in any form. Except as stated above the SOFTWARE PRODUCT is provided without warranty, express or implied, including without limitation the implied warranties of merchantability and fitness for a particular purpose.

4. PROTECTION DEVICE. In the event the SOFTWARE PRODUCT requires the use of a PROTECTION DEVICE to operate, you are specifically prohibited from attempting to bypass the functionality of the PROTECTION DEVICE by any means. A lost or stolen PROTECTION DEVICE will not be replaced by RISA TECHNOLOGIES.

5. TERMINATION. RISA TECHNOLOGIES may terminate your right to use the SOFTWARE PRODUCT if you fail to comply with the terms and conditions of this agreement. In such event you must delete any installations and destroy any copies of the SOFTWARE PRODUCT and promptly return the SOFTWARE PRODUCT to RISA Technologies.

6. CHOICE OF LAW. By entering into this Agreement in accordance with Paragraph 1, above, you have agreed to the exclusive jurisdiction of the State and Federal courts of the State of California, USA for resolution of any dispute you have all relating to the SOFTWARE PRODUCT or related goods and services provided by RISA Technologies. All disputes therefore shall be resolved in accordance with the laws of the State of California, USA and parties to this Agreement expressly agree to exclusive jurisdiction within the State of California, USA. No choice of law rules of any jurisdiction apply.

Installation

Installation Instructions

To install RISA-2D, please follow these instructions:

- Contact RISA Technologies licensing department (license@risa.com) for a program installation link.
- Click on the link from the email that they will send you.
- Follow the on-screen instructions.

RISA-2D Customization—Important Assumption!

Please ensure that when performing these tutorials, RISA-2D has not been customized in any way, and is in the default, installed state. If the installation of RISA-2D has been customized, you may reset the program defaults as follows: on the **Tools** menu, click **Reset All Program Defaults**.

Maintenance

Program maintenance provides all upgrades to RISA-2D, discounts on new products, and top priority for technical support.

When your maintenance expires, you will be given the opportunity to continue program maintenance on an annual basis. You are under no obligation to continue program maintenance, of course, but if you decide to discontinue maintenance you will no longer receive RISA-2D program upgrades and you will not be eligible for technical support once the version of the program you ended with becomes obsolete.

First Look at RISA-2D

Starting RISA-2D

This section describes the RISA-2D user interface, the toolbars, and shortcuts. We recommend that you review this section before you begin the tutorials.

Start RISA-2D as follows:

- ◆ On the **Start** button, click **All Programs**, select **RISA**, then select **RISA-2D**.

Windows and Dialog Boxes

When you first start up RISA-2D, you will be presented with the following screen:

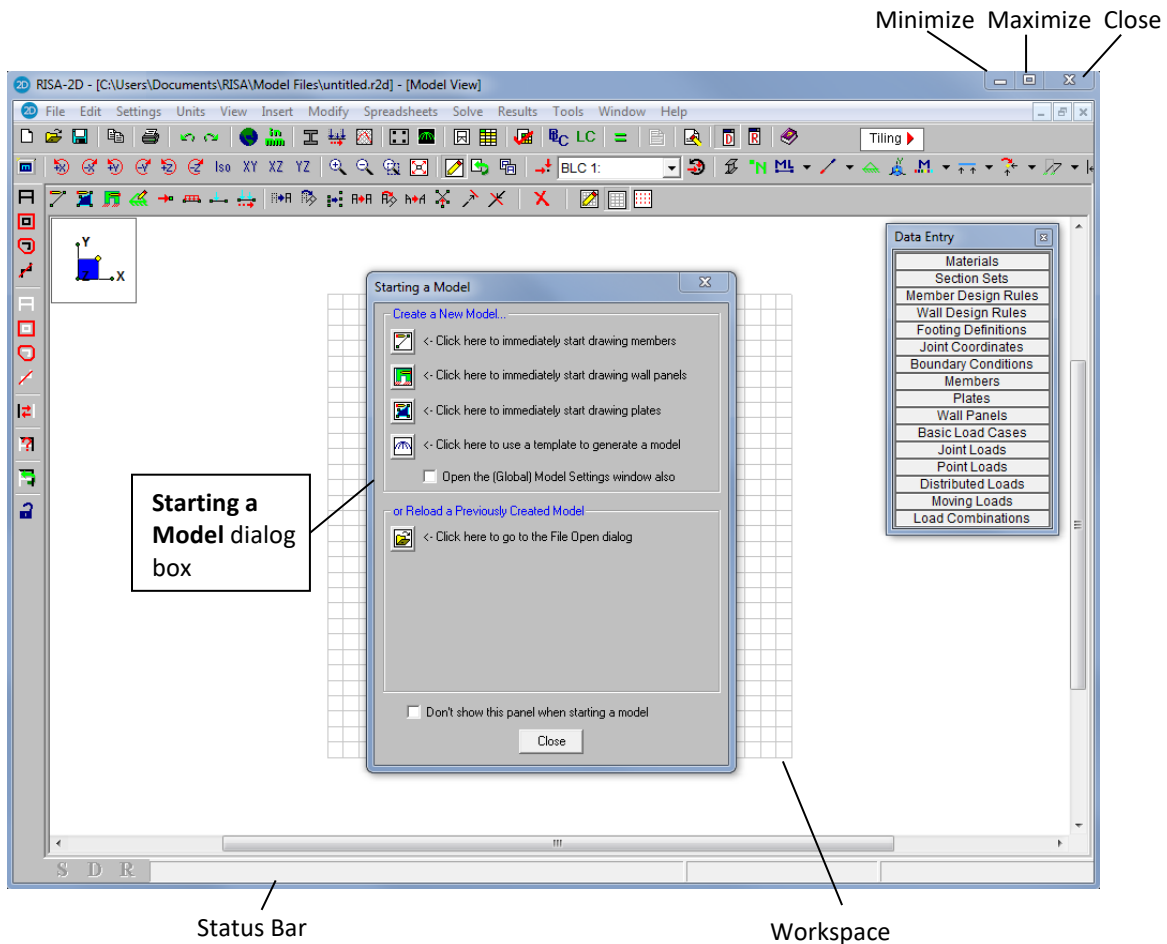



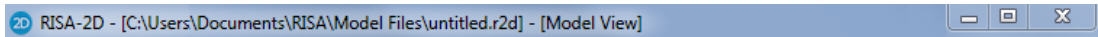

Title bar The title bar at the top of your RISA-2D window can be very useful. Besides containing the name of the file that is currently open, it can also be used to move the window and minimize, maximize, and resize the window.



To move the window, press and hold the title bar with your mouse, then drag to the desired location.

Minimize, Maximize, Close The three buttons  on the right of the title bar control the RISA-2D window as follows:

- Click **Minimize**  to minimize the window to a button on the taskbar.
- Click **Maximize**  to maximize the window to full screen. Once it is full screen, click **Restore Down**  to restore the window down to its original size.
- Click **Close**  to close the window.

Workspace The actual work that you do in RISA-2D will be in the main area on the screen, the workspace. Currently the workspace is empty except for the **Starting a New Model** dialog box. As you create new model views and spreadsheets they will also appear in the workspace.

Status bar The Status bar at the bottom of your screen will report information about your model as you work.

If the letter “S” is dimmed, a solution has not been performed. After a solution has been performed, the letter “S” will become blue in color with a red checkmark (as shown below). If the “S” is yellow, this means you have solution results but there have been modifications via the **Member Redesign** dialog box.

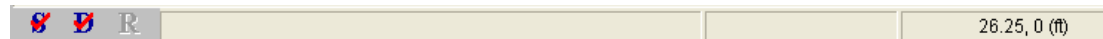

To the right of the “S” are 3 status boxes:

- The first status box displays general information relative to the task you are performing.
- The second (middle) status box reports the units of the current spreadsheet cell. As you move from cell to cell, look to the middle status box for the appropriate units. This box is empty if you are not working in a spreadsheet.
- The third status box (on the far right) reports the cursor coordinates as you work in the model view. This will be demonstrated throughout the tutorial.

Dialog boxes Dialog boxes are windows that help you perform a specific function within RISA-2D. For example, the **Starting a Model** dialog box is presented when you first open RISA-2D, which helps you find the file you wish to open.

Menus and Toolbars

Main Menu

File Edit Settings Units View Insert Modify Spreadsheets Solve Results Tools Window Help

The Main menu and its submenus provide access to all features RISA-2D has to offer, as summarized below:

File	Provides access to file operations such as opening, saving, and exporting files.
Edit	Provides editing tools that help you modify and manipulate the spreadsheets. You may use this menu to add or remove information from the spreadsheets or to sort and mathematically manipulate current spreadsheet data.
Settings	Provides access to the (Global) Model Settings dialog box which may be used to modify global solution and design settings.
Units	Allows you to set units or convert existing units.
View	Allows you to open a new model view or adjust the current model view.
Insert	Used to insert drawing grids, slabs, beams, footings, and loads into the model. All of these items may be drawn graphically or entered in the spreadsheets. This menu provides access to the graphical methods that RISA-2D provides, while the Spreadsheets menu gives you access to the spreadsheets.
Modify	Allows access to the graphic editing features and may be used to modify existing model elements.
Spreadsheets	Opens the spreadsheets.
Solve	Solves the model.
Results	Allows access to all analysis result spreadsheets. This button is dimmed when no results are available, such as before you run a solution.
Tools	Provides tools to help you organize, identify, and correct problems as you model the structure. Program Application Settings are also located here.
Window	Manages all of the windows that you have open in RISA-2D, whether they are spreadsheets or model views. Special tiling options are also available that relate to specific modeling tasks.
Help	Provides access to the RISA-2D online Help menu. For more information on Help, see <i>Using the Online Help</i> on page 3.

Toolbars

The most commonly used features available on the Main menu are also available on the toolbars as toolbar buttons. The toolbars are designed to speed up your workflow by placing these tools close to your workspace and making them easily visible.

Unlike some of the other toolbars, the RISA toolbar never changes. The other toolbars change, depending on whether you are in model (graphical) view or spreadsheet view.

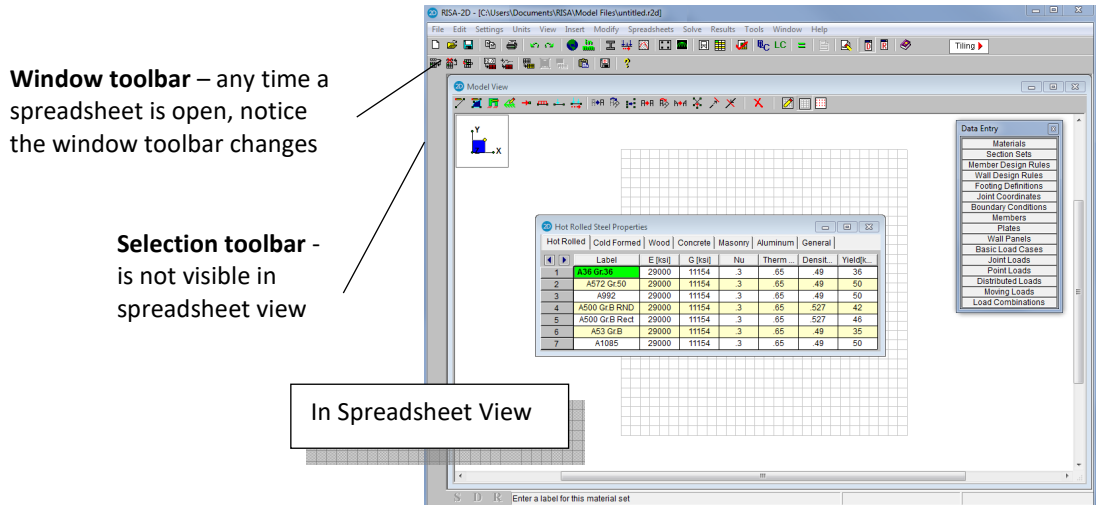
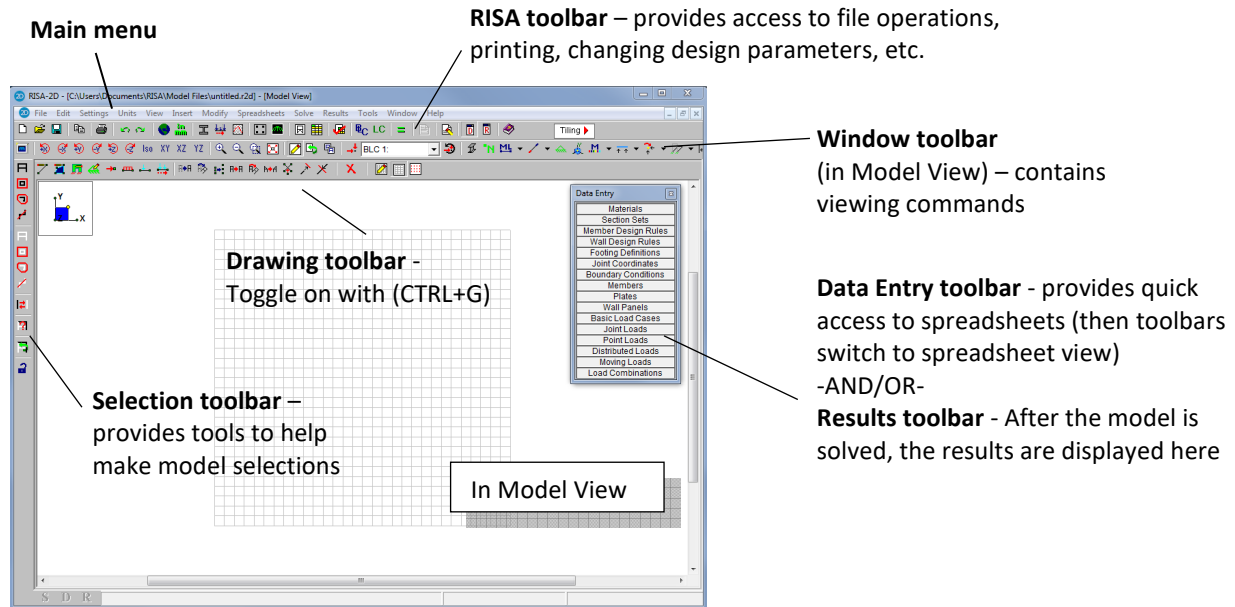

If you are not sure what a particular toolbar button does, simply position your mouse over the button and a short definition will display.

Note: You will discover many methods of accessing the tools available in RISA-2D. The methods you choose—whether menus, toolbars, or keyboard shortcuts—will simply be a matter of personal preference.

RISA Toolbar



The RISA toolbar is located directly below the Main menu. Unlike some of the other toolbars, the RISA toolbar never changes. These buttons perform general actions such as opening and closing files, changing design parameters, printing, and solving the model.

Window Toolbar

...in Model View



The Window toolbar is located directly below the RISA toolbar. When working in a graphic model view, the buttons provide model viewing tools, such as rotate and zoom, and others.

...in Spreadsheet View



When you are working in a spreadsheet, this toolbar provides spreadsheet editing tools, such as Sort, Block Fill and Block Math.

Drawing Toolbar



The Drawing toolbar provides tools to assist with creating and modifying your model graphically. This toolbar may be turned on and off (CTRL+G) as needed.





Selection Toolbar

...only visible in Model View

The Selection toolbar is the vertical toolbar along the left side of the screen. It provides tools to help you select and unselect parts of the model. You will need to make selections when you do things like graphically edit a part of the model or print only part of the results.

Spreadsheet Toolbars
(Data Entry and Results Toolbars)

These two toolbars provide access to the spreadsheets. You can turn them on and off on the RISA toolbar by clicking the **Data Entry** button  or the **Results** button .

The **Data Entry** toolbar is a vertical toolbar on the right of your screen. It looks different than the other toolbars because its buttons consist of text instead of images.

The **Results** toolbar is very similar. It appears after the model has been solved and provides quick access to the results spreadsheets.

Both toolbars allow you to access the spreadsheets very quickly while building and solving your model. The buttons appear in the general order as you may need them.

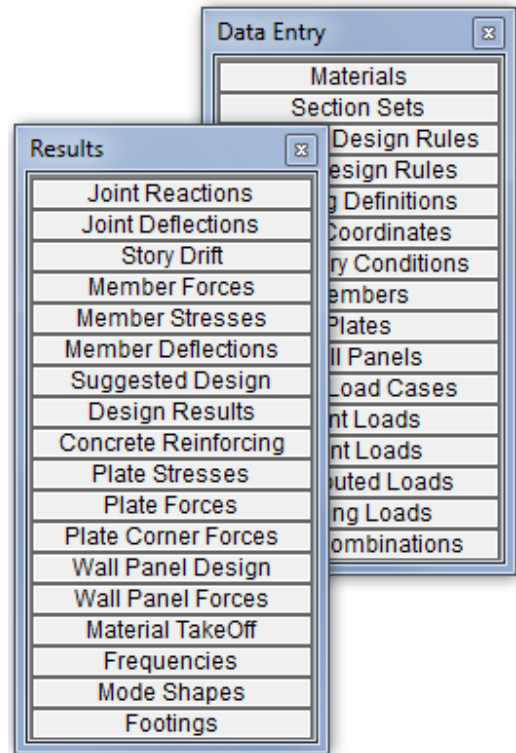

Managing Windows, Model Views, and Spreadsheets

Managing Windows

As you work in RISA-2D, you will be working within model views and spreadsheets, each in their own window that may be moved around the workspace and resized as you wish. A powerful feature of RISA-2D is the ability to have multiple model views and spreadsheets open at one time. The Window menu provides many options to help manage the display of these windows.

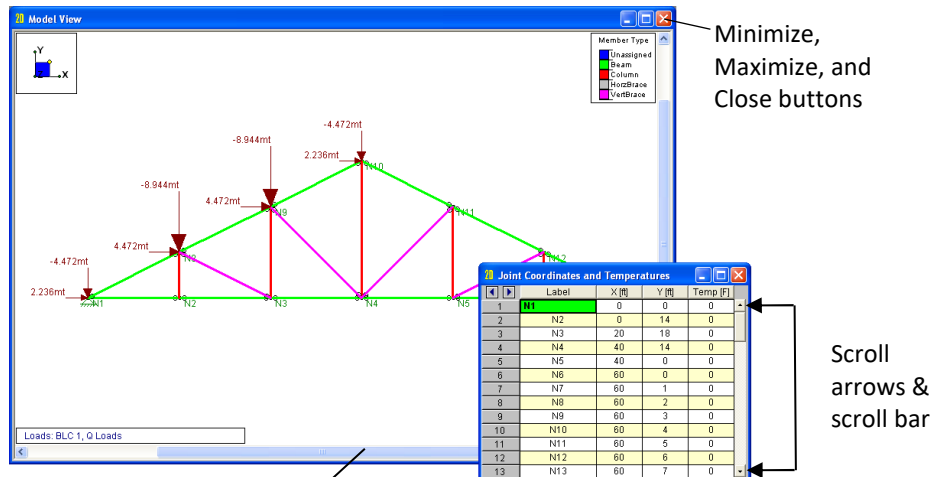

Scroll bar - to view information outside of the window's viewing area, click the scroll arrows or drag the scroll bar to move the display one way or the other.

Managing Model Views

You may open as many model view windows as you like. This is especially helpful when working zoomed in on large models. You might have one overall view and a few views zoomed in and rotated to where you are currently working. You may have different information plotted in each view.

Remember that the toolbars displayed by RISA-2D vary depending on which window is active (the window with a colored title bar is the active window).

For example, if your active window is a spreadsheet, and you are looking for the zoom toolbar, you will not be able to locate it until you click your model, switching to model view. Then you will be able to access the zooming tools, and all the other tools related to modeling.

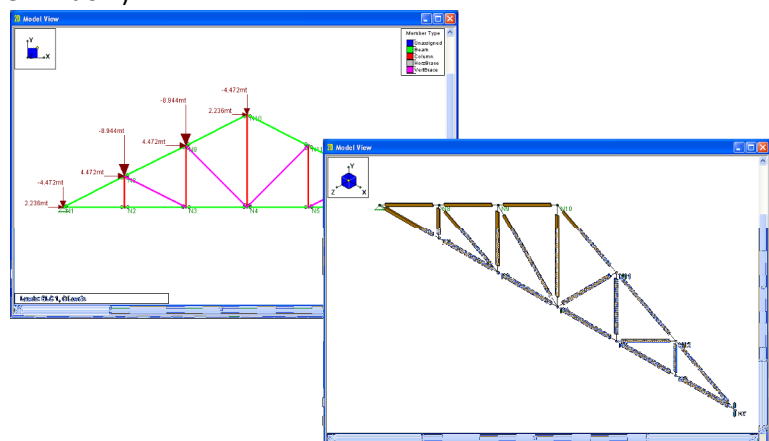

Working in Spreadsheets

Spreadsheets are comprised of rows and columns of data cells. To add or edit data in a cell, click the cell, making it the active cell, then type. Only one cell can be active at a time, and it is denoted in green. You can change which cell is active using the LEFT ARROW, RIGHT ARROW, PAGE UP, PAGE DOWN, HOME keys, etc.

You may also select blocks of cells to work on. To select a block of cells, click and hold the mouse button in the first cell in the block, drag to the last cell in the block, then release the mouse. To select an entire row or column, simply click the row or column label. To select multiple rows or columns, click and drag the mouse across multiple row or column buttons.

	Label	X [ft]	Y [ft]	Temp [F]
1	N1	15	75	0
2	N2	30	70	0
3	N3	0	70	0
4	N4	30	60	0
5	N5	15	60	0
6	N6	0	60	0
7	N7	30	50	0
8	N8	15	50	0
9	N9	0	50	0
10	N10	30	40	0
11	N11	15	40	0
12	N12	0	40	0
13	N13	30	30	0
14	N14	15	30	0
15	N15	0	30	0

Column label – Click the column label to select the entire column

Scroll bar

Column of cells

Row of cells – Click the row label (at left) to select the entire row

Click any cell. Notice the Status Bar displays an explanation of the current column.

Tutorial 1 – Modeling

Overview

The four tutorials contained in this User's Guide are designed to help you explore both the spreadsheet and graphic drawing capabilities of RISA-2D. The tutorials demonstrate not only how you build your model, but also how you make changes to the model to make it more efficient, or when design modifications become necessary.

The tutorials build upon themselves from start to finish. You have the option of performing them all at one time, or performing each one separately. To make this possible, RISA provides model files for you to load at the beginning of each tutorial. These starter files are located in the RISA program folder under **Tutorials**, and are named **RISA-2D Tutorial 2 starter.r2d**, **RISA-2D Tutorial 3 starter.r2d**, etc.

In Tutorial 1, you will create a frame comprised of two steel columns supporting a wood truss. In Tutorial 2, you will copy the frame into a 2-bay model and make modifications. Tutorial 3 will demonstrate how to define loads in the model. Tutorial 4 will illustrate how to run static solutions and review the results. When you finish all four tutorials, the final product will look like this:

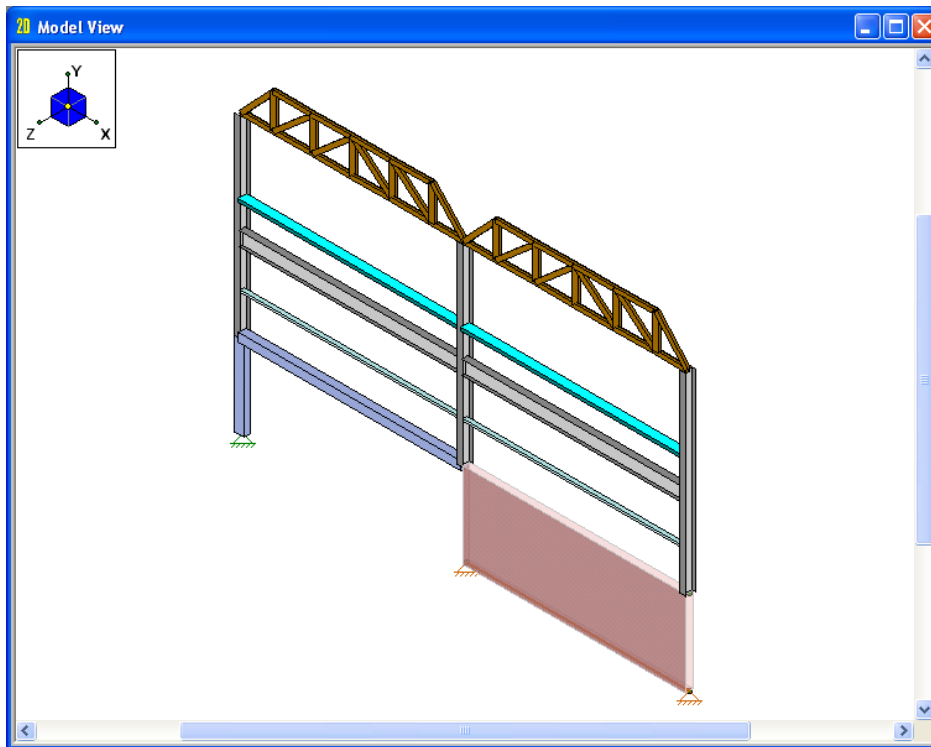

To complete all four tutorials will take only a few hours. However, you can speed up the process even further if you skip the supporting text and concentrate only on the action steps, which are indicated with diamond-shaped bullets, as shown below:

- ◆ In order for you to achieve accurate results, it is important that you do not miss any of these action steps while performing the tutorials.

Starting a New File

When you are ready to begin, start RISA-2D if you have not already done so:

- ◆ Double-click the **RISA-2D** icon to start the program. The **Starting a Model** dialog box will display, which allows you to create a new model or open an existing file.

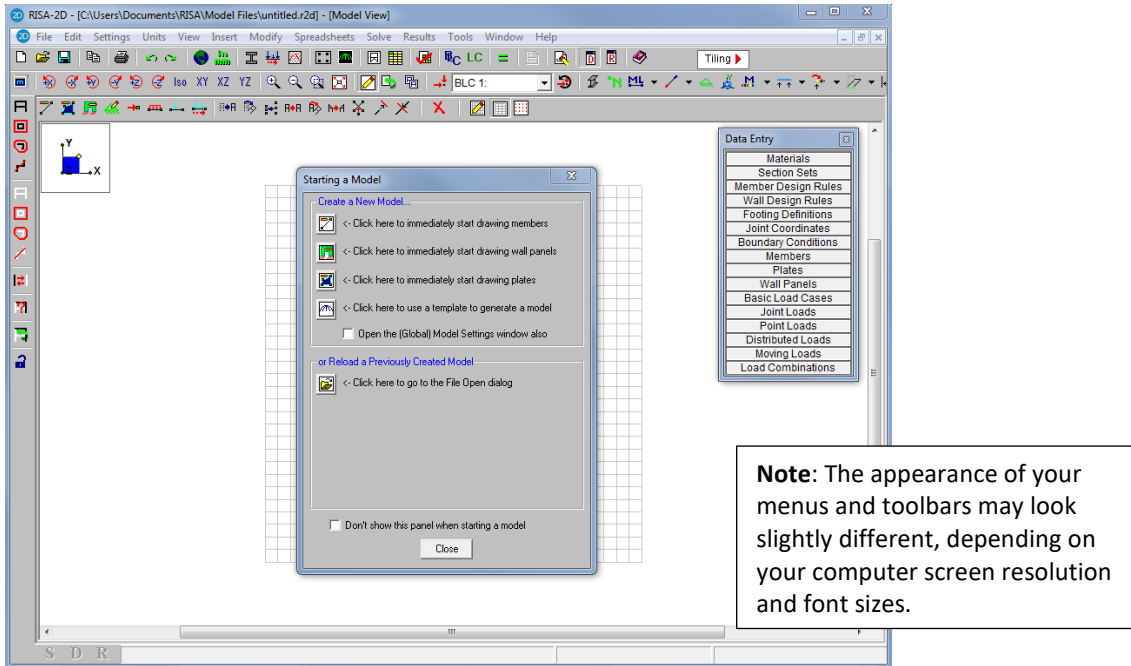

You have several startup options, along with a blank drawing grid placed in the workspace. You can choose to start drawing your model (either by defining members, or using a template to generate it automatically); you can open an existing model; or you can click **Close**  to work on your own.

Automatically Generating with Templates

RISA-2D has powerful templates that automate the generation of structures. Although you will not be using them for the tutorials, it is helpful to know a bit about them for future use. You may access these templates two ways: (1) on the **Starting a Model** dialog box, select  **Click here to use a template to generate a model**; or, (2) on the **Insert** menu, click **Structure(Generate)**.

Some of the templates are very specific (such as the **Parabolic Arc** template), while others are general (such as the **Circular Disk With Plates**). Using these templates, you can generate almost any typical or repetitive model or model component.

Once you complete the tutorials and learn how to build structures without the templates, you will be able to more easily understand how and when to use templates. This will speed up your day-to-day workflow and make RISA-2D even more powerful.

Start Modeling

Begin creating your model by drawing members:

- ◆ Under **Create a New Model**, select the **Open the (Global) Model Settings window also check** box. This will save you a step by opening the **(Global) Model Settings** dialog box after you make your starting selection.
- ◆ Select  **Click here to immediately start drawing members.**

Because you selected the **Open (Global) Model Settings** check box option, the **(Global) Model Settings** dialog box opens first.

(Global) Model Settings

This dialog box provides access to global settings that apply to the model as a whole.

Set the **(Global) Model Settings** as follows:

- ◆ Type a model title, company name, and your name, as shown below.
- ◆ Click **Apply**. The dialog box will remain open.

The (Global) Model Settings dialog box:

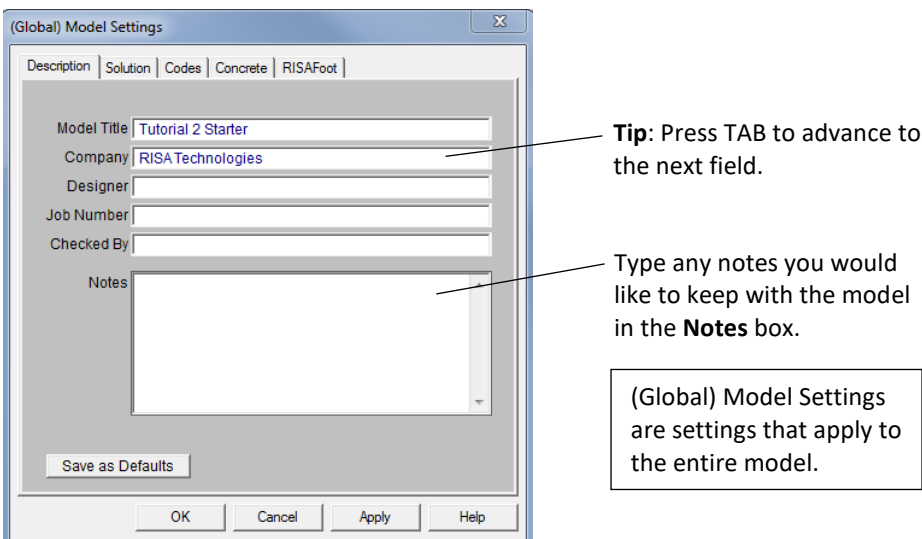

Review and modify the **Solution** parameters:

- ◆ In the **(Global) Model Settings** dialog box, click the **Solution** tab.
- ◆ In the **Number of Sections** box, type **7** (or you may use the up/down arrows to increase/decrease the value).
- ◆ Click **Apply**.

The dialog box will remain open, and should now look like this:

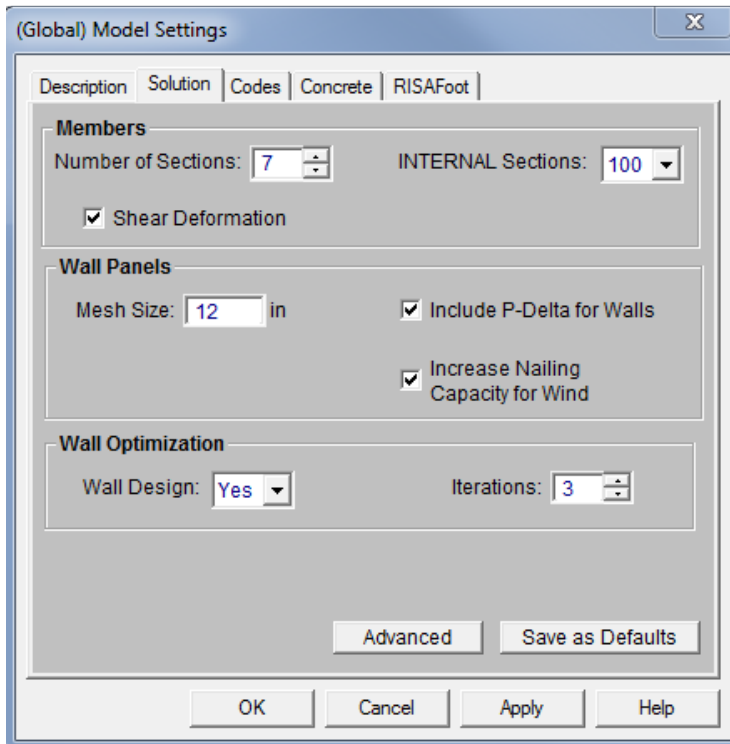

Below is a description of all the available solution parameters:

Number of Sections	Specify how many locations along each member are to be used for the reporting of forces, stresses, and deflections.
INTERNAL Sections	Controls how many places along each member RISA-2D calculates and stores results, such as deflections and code checks. The member force diagrams displayed in the model view and the detail plot are also drawn from these results.
Shear Deformation	This check box indicates whether or not shear deformation considerations are to be included in the model solution.
Wall Mesh Size	Defines the base wall panel mesh size.
Include P-Delta for Walls	This is used to enable P-Delta analysis for wall panels. Note that this will only be performed on load combinations that have P-Delta included.
Increase Nailing Capacity for Wind	Selecting this option will automatically increase the shear capacity of wood wall and diaphragm panels by 1.4 for all wind load load combinations. Note that load combinations with both seismic and wind loads will <i>not</i> receive this increase.
Wall Design	This selection indicates whether or not you want your wall panel design to be optimized.
Iterations	This designates the number of iterations that the wall design feature will go through for the wall optimization.

Review the options for the **Code** parameters:

- ◆ In the **(Global) Model Settings** dialog box, click the **Codes** tab.

For this tutorial, the default settings will be used.

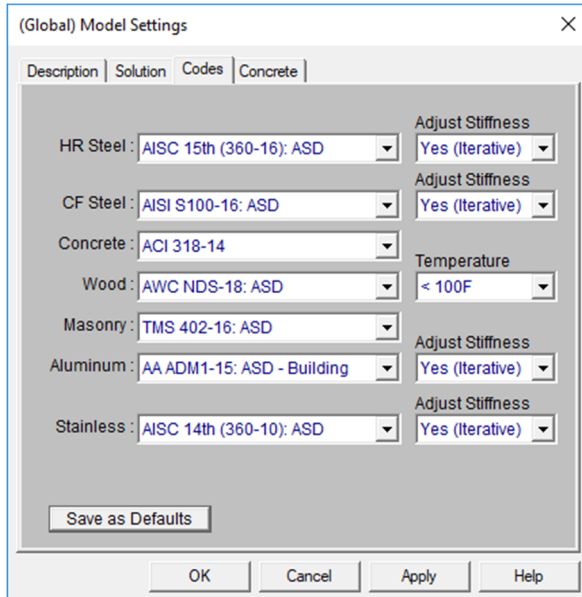

These settings control how code checking is performed, as described below:

Hot Rolled Steel	Code choices include <i>AISC 15th (360-16) ASD & LRFD, 14th (360-10) ASD & LRFD, 13th (360-05) ASD & LRFD, 9th Edition ASD, 2nd Edition LRFD, 3rd Edition LRFD</i> , and several international steel codes. If the AISC 360 code is selected, the Adjust Stiffness menu will appear. The options in this menu control the stiffness reduction provisions per App. 7 of the code.
Cold Formed Steel	Code choices are <i>AISI S100-16 (ASD&LRFD), AISI S100-12 (ASD&LRFD), AISI S100-10 (ASD&LRFD), AISI S100-07 (ASD&LRFD), AISI NAS-04 (ASD&LRFD), AISI NAS-01 (ASD&LRFD), AISI 99 (ASD & LRFD)</i> , and several international codes. If the AISI S100-16 code is selected, the Adjust Stiffness menu will appear. The options in this menu control the stiffness reduction provisions of the code.
Concrete	Code choices include the <i>99, 02, 05, 08, 11, & 14 Editions of ACI</i> along with several international codes.
Wood	Code choices include the <i>97, 01, 05/08, 12, 15 & 18 Editions of the NDS</i> .
Wood Temperature	This selection is used to calculate the temperature factor (Ct) used in the design of wood members.
Masonry	Code choices include <i>TMS 402-16 (ASD & Strength), ACI 530-13 (ASD & Strength), ACI 530-11 (ASD & Strength), ACI 530-08 (ASD & Strength), ACI 530-05 (ASD & Strength), ACI 530-02 (ASD & Strength)</i> along with several international codes.
Aluminum	Code choices include <i>AA ADM1-15 ASD (ASD&LRFD Building & ASD Bridge), AA ADM1-10 ASD (ASD&LRFD Building & ASD Bridge), and AA ADM1-05 ASD (Building & Bridge)</i> .

Tutorial 1 – Modeling

Adjust Stiffness	Determines whether or not the stiffness adjustments per <i>AA ADM1</i> are applied to your members.
Stainless	Code choices include the <i>AISC 14th (360-10) ASD & LRFD</i> . The options in the Adjust Stiffness menu control the stiffness reduction provisions of the code.

Review and modify the options for the **Concrete** parameters:

- ◆ In the **(Global) Model Settings** dialog box, click the **Concrete** tab.
- ◆ Under **Concrete Stress Options**, click **Parabolic Stress Block**. This method is the more accurate of the two methods.
- ◆ Click **Apply**.

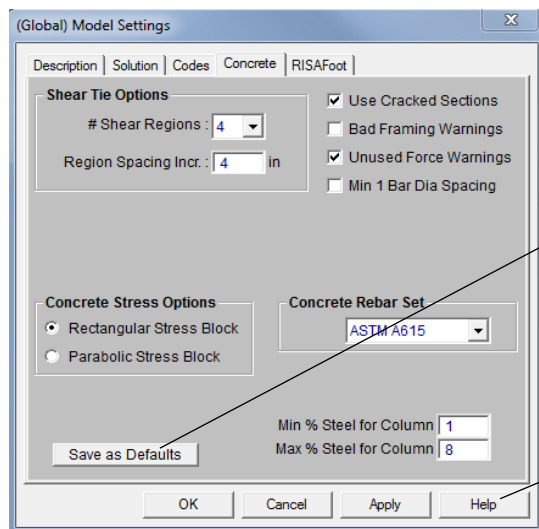

Click **Save As Defaults** any time to save all current settings to become the new default settings for all future models.

Click the **Help** button to open the Help Menu to the relevant topic.

These settings contain options related to the analysis and design of concrete members as described below:

Shear Tie Options	Allows you to control the number of shear regions that will be used when detailing a beam or column span. It also allows you to specify an increment when increasing or reducing the spacing of the shear ties.
Concrete Stress Options	Allows you to choose what type of stress block to consider in your analysis. The options are the constant Rectangular Stress Block and the Parabolic Stress Block .
Concrete check boxes	<p>Use Cracked Sections - modifies the member stiffnesses by the Icr Factor. For more information, refer to <i>RISA-2D General Reference</i>.</p> <p>Bad Framing Warnings - helps you detect modeling errors during solution. It produces a message in the error log whenever an unsupported member is detected at either of its end joints (can be common for models that contain cantilevers, rafters, etc.)</p> <p>Unused Force Warnings - produces messages on the member detail report when weak axis and torsional moments have been neglected.</p>

	Minimum 1 Bar Dia Spacing - allows a minimum spacing of one bar diameter between parallel bars. Otherwise, RISA-2D will default to a two bar diameter or one inch clear spacing, whichever is greater, to allow for lap splices and continue to maintain adequate spacing between parallel bars.
Concrete Rebar Set	Allows you to specify the grade of rebar you wish to use. You can also specify a Minimum % Steel and Maximum % Steel for column reinforcement.

Before closing the **(Global) Model Settings** dialog box, notice you will also see a tab labeled **Footings**. If you have RISAFoot installed, this will allow you control over footing design input. If you do not have RISAFoot installed, this tab will only state that you need to install the program in order to utilize the integration. For more information on this integration, please click **Help** or refer to *RISA-2D General Reference Manual*.

You may now close the **(Global) Model Settings** dialog box.

- ◆ Click **OK** to exit.

Members

Once you close the **(Global) Model Settings** dialog box, the **Draw Members** dialog box will display:

Before drawing the members, first define the material type to be used, either: Hot Rolled, Cold Formed, Wood, Concrete, Aluminum, Stainless or General. Once the materials are stored in RISA-2D, the spreadsheets and solution results will be sorted based on that material. When performing a solution, RISA-2D will only analyze and/or design members for load combinations that are appropriate for that material (this will be discussed in more detail in *Tutorial 3 – Loading*).

Tutorial 1 – Modeling

Define Hot Rolled Steel as the material type for the new members you will be creating:

- ◆ Under **Member Material Type and Shape**, click **Hot Rolled**.

Next, you need to decide how you want to define the cross-sectional properties of the member. You can assign a shape directly, or define your properties based on section sets.

For now, start with a 12x53 column, and assign your concrete shapes directly. (Later you will use section sets for your wood truss and concrete members.)

- ◆ Click **Assign Shape Directly**.

This bypasses the section sets and allows you to assign an explicit shape for these new members:

- ◆ Under **Start Shape**, highlight and type **W12x53**.
- ◆ Under **Type**, select **Column**.
- ◆ Under **Design List**, select **Wide Flange**.
- ◆ Under **Material**, select **A992**.

The dialog box should now look like this:



The screenshot shows the 'Draw Members' dialog box with the following settings:

- Member Material Type and Shape:**
 - Hot Rolled** (selected)
 - Assign a Section Set (HR1A)
 - Cold Formed
 - Wood
 - Concrete
 - Aluminum
 - Stainless
 - General
 - Assign Shape Directly
 - Start Shape: W12x53
 - Type: Column
 - Design List: Wide Flange
 - Material: A992
 - Design Rule: Typical
- Member Label Prefix:** M
- Joint Label Prefix:** N
- Release Codes:**
 - Fully Fixed at Both Ends (selected)
 - Pinned at Both Ends
- Both Ways:** Both Ways
- Physical Member
- Top of Member
- Orientation:** Rotate Section: 0
- Drawing Options:**
 - Draw Point to Point
 - Draw Beam to Beam (1st Offset: 1 ft, %; 2nd Offset: 1 ft, %)
 - Draw Point to Beam (Beam Offset: 1 ft, %)
- Keep this dialog open
- Buttons: Apply, Close, Help

The release codes are used to designate whether the forces and moments at the ends of the member are considered fixed to or released from the member's points of attachment (the end joints).

Verify the settings, then prepare to start drawing:

- ◆ Click **Apply**.

Note: After you click **Apply**, your cursor changes to , indicating that you are now in the drawing mode. Also notice that on the Drawing toolbar, the **Draw New Members**  button is pressed in.

Drawing Grid

Before you begin drawing, notice that RISA-2D will always open a default 30x30 grid spaced at one foot. To make it easier to find your column and beam locations for this tutorial, redefine the grid as follows:

- ◆ On the Drawing toolbar, click the **Modify Drawing Grid**  button to redefine the grid. The **Drawing Grid** tab should already be selected.

Change the grid increments as follows:

- ◆ Under **Rectangular Grid Increments**, in the first column under **X Axis**, highlight and delete any current data and type: **3,4@3.75,3** (including the commas).
- ◆ In the first column under **Y Axis**, highlight and delete any current data and type: **10,8,5,4** (including the commas).

The dialog box should now look like this:

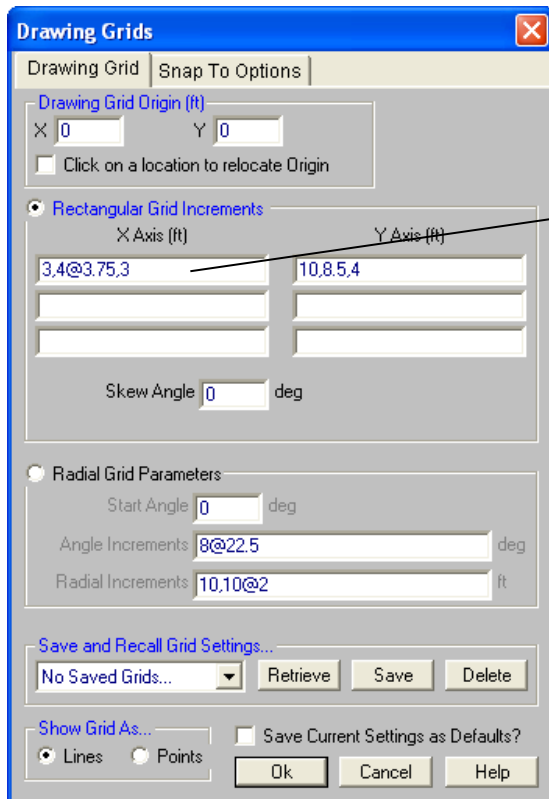

These settings define a drawing grid with an initial X-increment for the truss points of 3 ft, followed by 4 equal increments of 3.75 ft each (denoted by the "@" symbol), and a final increment of 3 ft.

Other options available: you may specify a radial grid, you may save the grid layout to use in other models, and you may make this the default grid layout.

Close the **Drawing Grids** dialog box and the **Data Entry** toolbar.

- ◆ Click **OK** to close the dialog box.
- ◆ Click **Close**  to close the **Data Entry** toolbar (upper right corner of your workspace).

Drawing Members

As you move your cursor around the drawing grid (specifically over grid intersections), notice RISA-2D displays the coordinate location of the cursor in the lower right corner of the Status bar.



The coordinates displayed on the Status bar are the coordinates of the grid point or joint location closest to the cursor. Notice the coordinates change as you move the mouse around. Also, when you are in the drawing mode (as you are now), the points are highlighted by a red dot any time the tip of your mouse approaches the point.

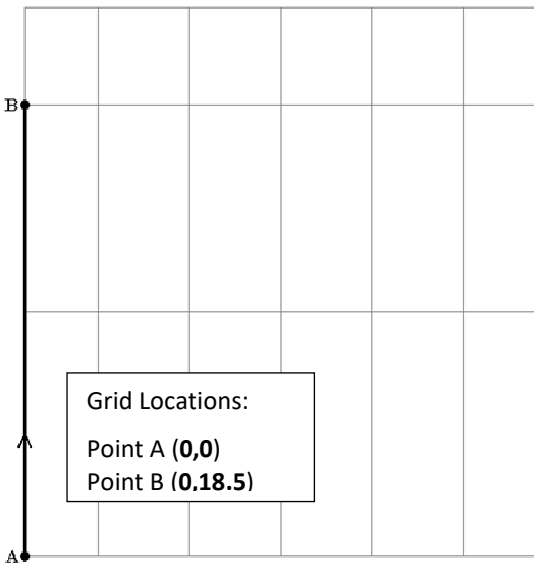

As you continue the tutorial, ensure that you draw the members in the specified location by watching the Status bar to verify the exact coordinate location.

Start by drawing a line from point **A** to point **B**, as shown in the image above:

- ◆ Place the cursor on the lower left corner of the grid to create point **A** (coordinates **0,0**) and click once. (Notice a joint has been created and labeled **N1**.)
- ◆ Next, move the mouse straight up to point **B** (coordinates **0,18.5**) and click again. (Another joint has been created and labeled **N2**.)

Note: After drawing a member, your cursor remains linked until you either draw another member or terminate drawing. To terminate drawing, right-click the mouse or press ESC.

Your screen should now look like this:

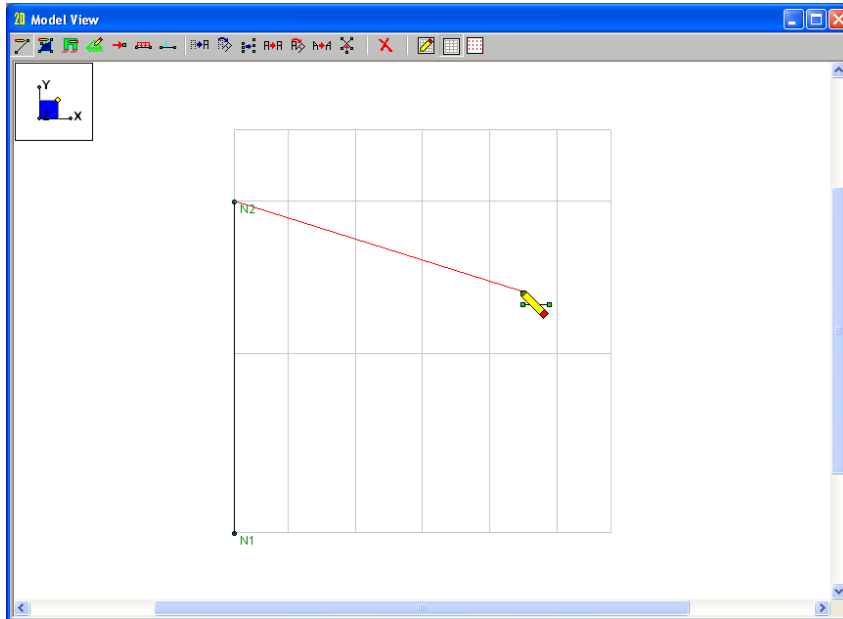

To release the mouse:
Right-click the mouse or
press ESC when finished
drawing.

To undo any mistakes:
Press the **Undo** button or
CTRL+Z.

- ◆ When finished drawing the line, right-click to release the mouse.

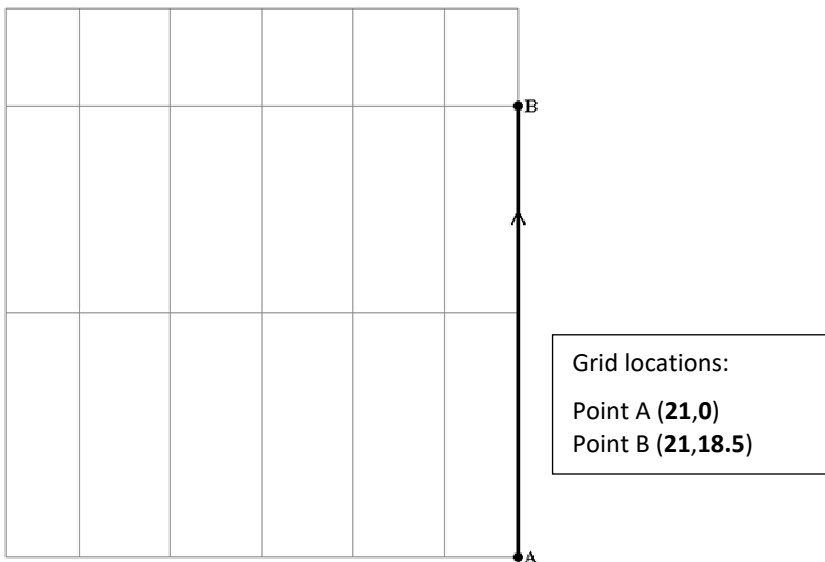

Draw another line from point **A** to point **B**, as shown in the image above:

- ◆ To create point **A**, place the cursor on the lower right corner of the grid (coordinates **21,0**) and click once. (The new joint has been created and labeled **N3**.)
- ◆ Next, move the mouse straight up to point **B** (coordinates **21,18.5**) and click again. (The new joint has been created and labeled **N4**.)
- ◆ When finished drawing the line, right-click to release the mouse. Right-click a second time to exit the drawing mode.

Tutorial 1 – Modeling

Now you should have a column on the left, extending from joint **N1** to joint **N2**, and another on the right, from joint **N3** to **N4**.

Before drawing the truss, take a moment to change the way that members are shown and color-code them by their section sets.

- ◆ On the Window toolbar, click **Model Display Options** .

The Model Display Options will be discussed in more detail later. For now, just change the color coding:

- ◆ In the dialog box, click the **Members** tab.
- ◆ Click **Color Coded**. Under **Color Basis**, select **Section Set**. Under **Labeling**, select **No Labeling**.

Now the dialog box looks like this:

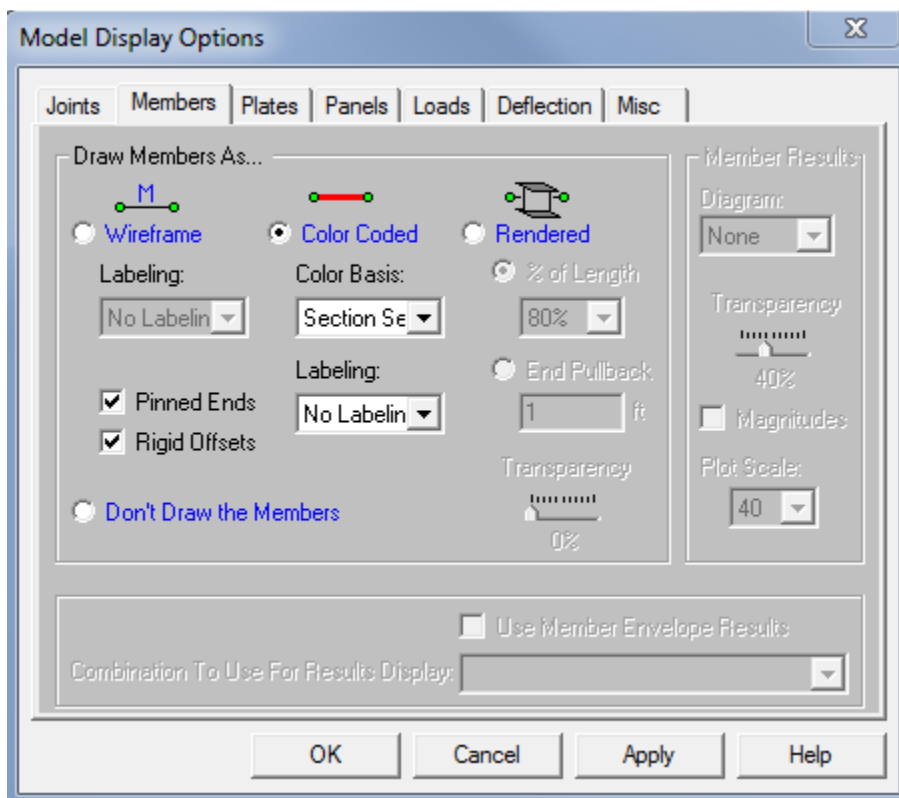

These settings will color code the members by their section sets. Close the dialog box and return to your model:

- ◆ Click **OK**.

The members should now be displayed in color and a legend is now displayed in the upper right corner of the workspace. Notice that the description appears in the legend as “na” because the section sets have not yet been defined.

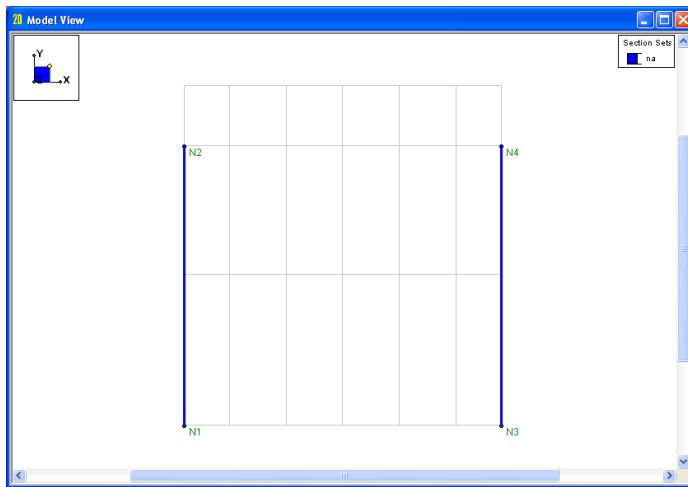

Now that the columns are defined, move ahead to the truss members. To resume drawing:

- ◆ On the Drawing toolbar, click the **Draw New Members** button .

You will now define your truss members as you would a section set. This allows you to group similar members for easier modeling and modifying. Because you have not yet defined any section sets, you will first place the members in the sets as you build the model, then define the properties (section sets) later.

- ◆ Under **Member Material Type and Shape**, click **Wood**.
- ◆ Then click **Assign a Section Set** to assign a section set for your new members. (The available options for Wood will appear.)

The dialog box should now look like this:



Tutorial 1 - Modeling

Return to the model view and resume drawing:

- ◆ Click **Apply**.

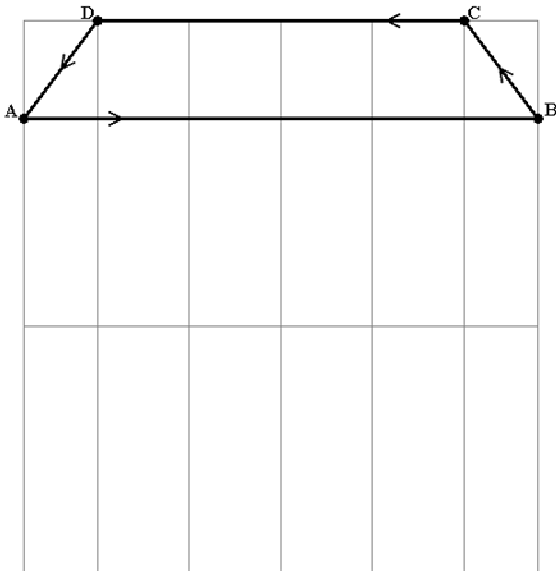

Grid Locations:

Point A (**0,18.5**)
Point B (**21,18.5**)
Point C (**18,22.5**)
Point D (**3,22.5**)

Note: Because the truss chords were defined as a section set, they will display in a different color than the columns.

Using the grid locations shown above, draw the truss chord:

- ◆ Draw members from points **A** to **B**, then **B** to **C**, then **C** to **D**, and lastly from **D** to **A**.
- ◆ Right-click the mouse or press ESC two times to release the mouse and exit the drawing mode.

Next, you will draw the web members using the section set again. Later, you will modify this to differentiate the web members from the truss chords using separate section sets. Another way to get back to the **Member Properties** dialog box is to use the shortcut menu:

- ◆ Right-click the mouse (from anywhere in your workspace) to activate the Shortcut menu.

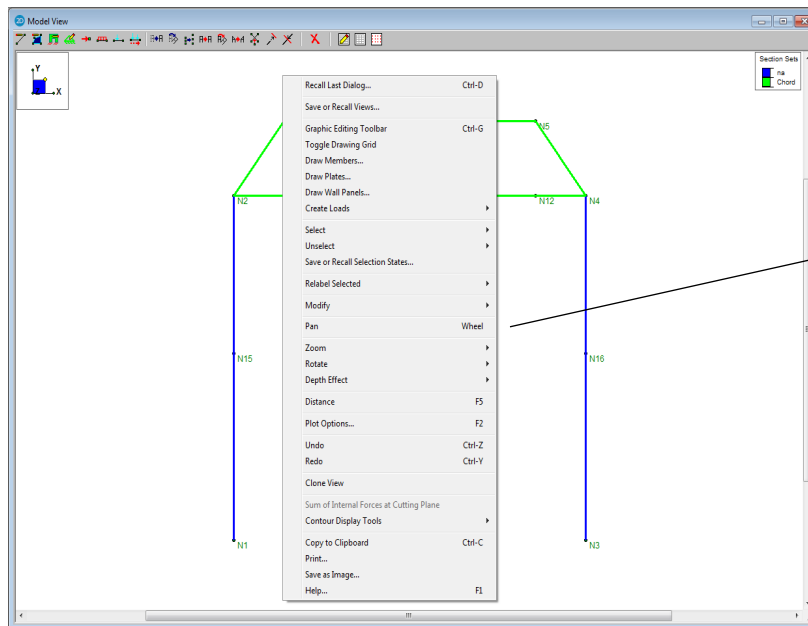

To activate the Shortcut menu, right-click the mouse from anywhere on the workspace.

The shortcut menu displays options available that relate to the tasks you are performing. These options are specific to your current view. For example, if you were viewing a spreadsheet, the choices would be relevant to spreadsheets.

Next, recall the **Draw Members** dialog box and redefine the web members to be pinned at both ends:

- ◆ On the shortcut menu, click **Recall Last Dialog** to display the **Draw Members** dialog box again.
- ◆ Under **Release Codes**, click **Pinned at Both Ends**.

The dialog box should now look like this:

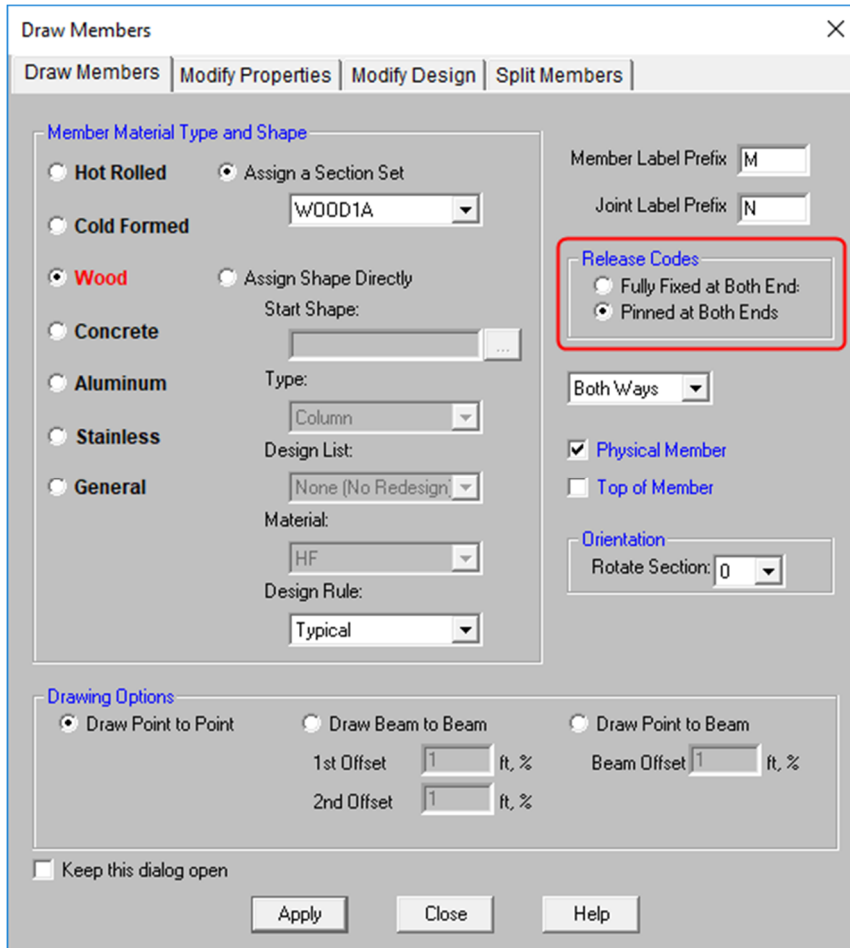

Exit the dialog box:

- ◆ Click **Apply**.

Tutorial 1 - Modeling

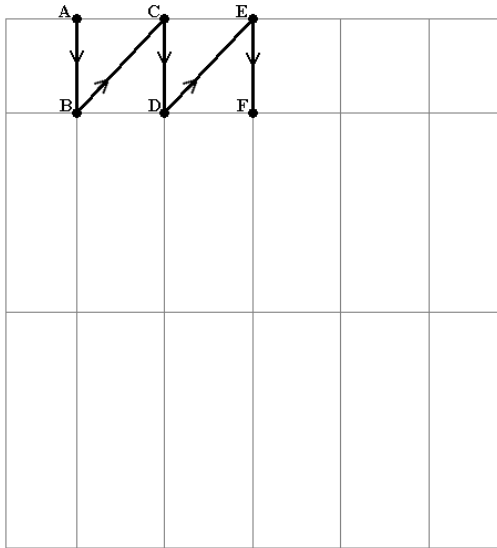

Grid Locations:

Point A (3,22.5)
Point B (3,18.5)
Point C (6.75,22.5)
Point D (6.75,18.5)
Point E (10.5,22.5)
Point F (10.5,18.5)

Using the grid locations shown above, draw the web members:

- ◆ Draw members from points **A** to **B**, **B** to **C**, **C** to **D**, **D** to **E**, then **E** to **F**.
- ◆ Right-click the mouse or press ESC to release the mouse.

Use a new starting point for the next series of members.

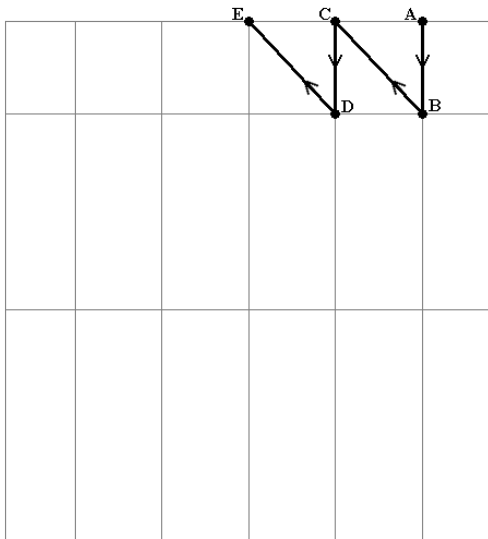

Grid Locations:

Point A (18,22.5)
Point B (18,18.5)
Point C (14.25,22.5)
Point D (14.25,18.5)
Point E (10.5,22.5)

Use the grid locations shown above to draw the next series of members:

- ◆ Draw members from points **A** to **B**, **B** to **C**, **C** to **D**, then **D** to **E**.
- ◆ Click the right mouse button or press ESC to release the mouse.

Your model should now look like this:

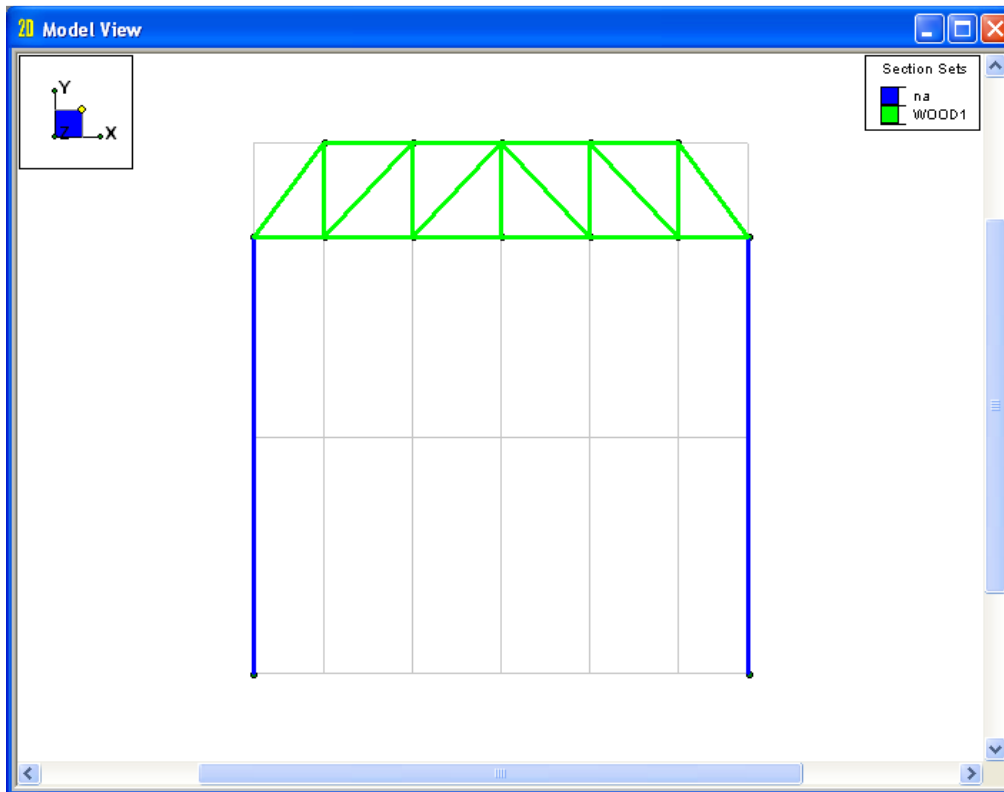

Physical Members

Notice that you have defined your truss chords with one member, rather than multiple members between each joint. RISA-2D's Physical Member feature allows you to quickly draw in members this way, rather than making you draw every member as split between nodes.

Physical Members automatically connect the members and nodes that frame into them along their midspan. Therefore, you do not have to use multiple members to model what is one Physical Member in the field. Therefore, if you later have to make changes to your model, you do not have to apply changes to multiple smaller members. Most important, the results values for this continuous member will not be spread out over multiple members, making it difficult to find design values--it will instead be presented as that of only one member.

Material Properties

RISA-2D provides default section sets for each basic material type. Later, you will create some additional section sets using the **Section Sets** spreadsheet. You will then define the section properties for all the truss members that you have defined so far.

Using the **Materials** spreadsheet, review your material properties.

- ◆ On the RISA toolbar, click the **Data Entry** toolbar  button to display the **Data Entry** toolbar.
- ◆ On the **Data Entry** toolbar, click **Materials**.

The **Materials** spreadsheet will display:

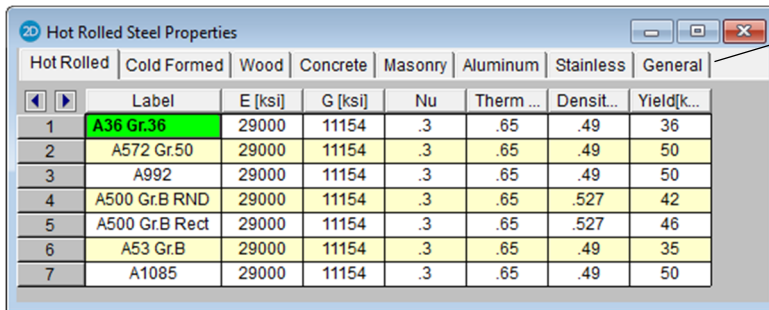

	Label	E [ksi]	G [ksi]	Nu	Therm ...	Densit...	Yield[k...
1	A36 Gr.36	29000	11154	.3	.65	.49	36
2	A572 Gr.50	29000	11154	.3	.65	.49	50
3	A992	29000	11154	.3	.65	.49	50
4	A500 Gr.B RND	29000	11154	.3	.65	.527	42
5	A500 Gr.B Rect	29000	11154	.3	.65	.527	46
6	A53 Gr.B	29000	11154	.3	.65	.49	35
7	A1085	29000	11154	.3	.65	.49	50

Notice the tabs contain the various material types. Click to review the information under each tab.

When you click any cell, notice the Status bar (bottom of the screen) gives an explanation of the current column.

Note: The United States default material values are built in to RISA-2D. However, you can create new default values for your future models by adding those materials into any spreadsheet and, on the Window toolbar, by clicking **Save as Defaults** .

For example, if you are working on a Canadian job with a steel that conforms to the G40.21 specification, you can add that material and save it for use on future models. On the Window toolbar, click **Save as Defaults** . Any new models will start with this steel material automatically.

Wood Properties

Next, modify the wood material for the truss members. The complete NDS species database is built into RISA-2D. Therefore, when defining the wood properties, you can select any valid species/grade combination, and RISA-2D will provide the design values.

Modify the grade of wood to be used:

- ◆ On the **Materials** dialog box, click the **Wood** tab.
- ◆ Go to the bottom of the spreadsheet and press ENTER.
- ◆ Type **DFL Select** as the **Label**.
- ◆ Press the TAB key three times.

The active (green) cell should now be in the **Species** column.

- ◆ Click in the **Species** menu. Review the list of available species by dragging the scroll bar up and down.
- ◆ Select **Douglas-Fir Larch**.

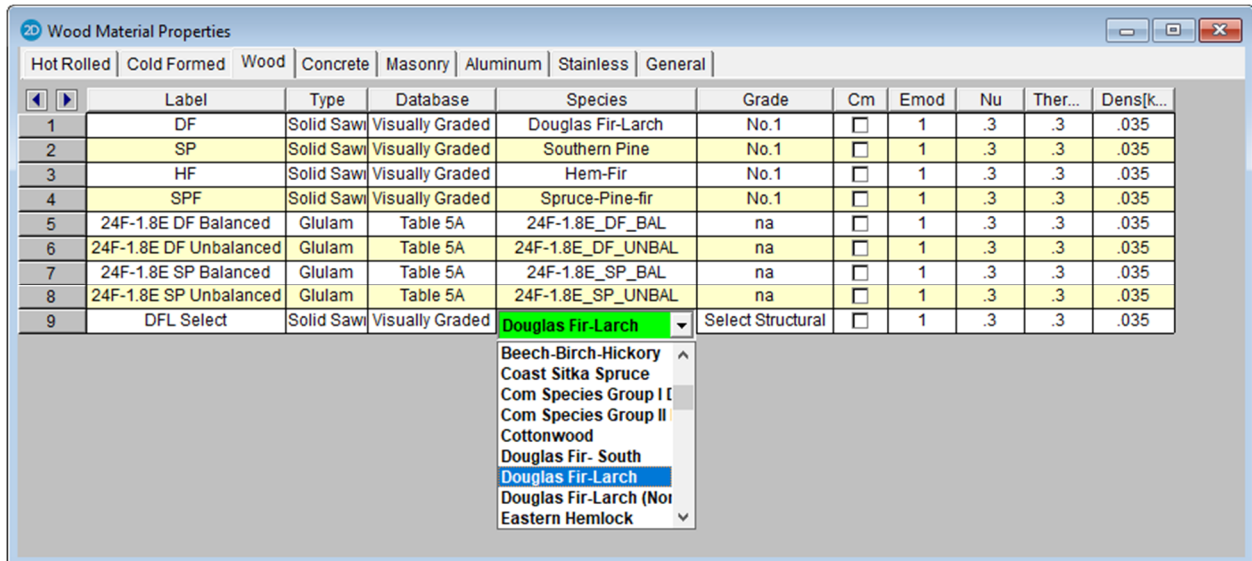

- ◆ Press the TAB key once to advance one column to the right.

The active (green) cell should now be in the **Grade** column.

- ◆ Click in the **Grade** menu. Review the list of available grades by dragging the scroll bar up and down.
- ◆ Click **Select Structural**.

Note: In the future, you may save any changes for future default values for new models by clicking the **Save as Defaults**  button. This button is located on the Window toolbar.

Now that you have defined the material properties, you will use them to define the members and section sets.

Design Rules – Size/UC

In an effort to optimize hot rolled, cold formed, wood, concrete, aluminum, and masonry members, RISA-2D will suggest a lighter, more efficient shape for each of the members. When suggesting an alternate shape, RISA-2D will only consider shapes that are included in the designated Design List. The Design List is a set of members that will be used in the design and optimization of a member.

For example, a section set could be defined with the Wide Flange Design List. This list references the redesign list which contains the US list of Wide Flange sections from the *AISC Manual of Steel Construction*. In this case, RISA-2D will never suggest that a Channel or H Pile would be a more efficient shape. For information about editing the existing Design Lists or creating your own custom Design Lists, refer to *RISA-2D General Reference*.

You may edit the default redesign lists at any time to create custom lists of your own. These lists are contained in *C:\RISA\risa_redesign_lists* and you may open/edit them in a text formatting program, such as Notepad.

Next, using the **Design Rules** spreadsheet, specify some additional restrictions as to what type of sections RISA-2D can select for redesign:

- ◆ On the **Data Entry** toolbar, click **Member Design Rules**.

The **Design Rules** spreadsheet will display:

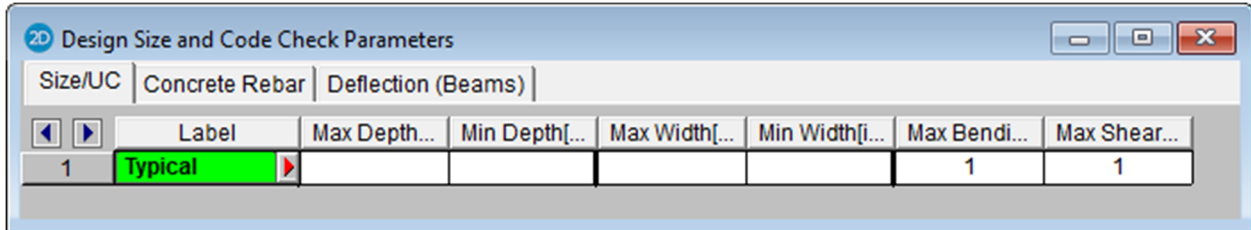

Enter the following data in row 1:

- ◆ In row 1, under **Label**, type **Col-Rules**. (Press the TAB key two times.)
- ◆ Under **Min Depth**, type **12**. (Press the TAB key two times.)
- ◆ Under **Min Width**, type **10**.
- ◆ Press ENTER.

Enter the following data in row 2 (continue pressing the TAB key to advance between columns):

- ◆ In row 2, under **Label**, type **Steel-Bms**.
- ◆ Under **Min Depth**, type **12**.
- ◆ Press ENTER.

Enter the following data in row 3:

- ◆ In row 3, under **Label**, type **Conc-Bms**.
- ◆ Under **Min Depth**, type **12**.
- ◆ Under **Min Width**, type **10**.
- ◆ Press ENTER.

Enter the following data in row 4:

- ◆ In row 4, under **Label**, type **Truss-Rules**.
- ◆ Under **Max Depth**, type **10**.
- ◆ Under **Min Depth**, type **3.5**.
- ◆ Under **Max Width**, type **6**.
- ◆ Under **Min Width**, type **1.5**.
- ◆ Press ENTER.

Enter the following data in row 5:

- ◆ In row 5, under **Label**, type **Alum-Rules**.
- ◆ Under **Max Depth**, type **6**.
- ◆ Under **Max Width**, type **6**.

Tutorial 1 – Modeling

When finished, the spreadsheet should look like this:

	Label	Max Depth...	Min Depth[...]	Max Width[...]	Min Width[ji...]	Max Bendi...	Max Shear...
1	Col-Rules		12		10	1	1
2	Steel-Bms		12			1	1
3	Conc-Bms		12		10	1	1
4	Truss-Rules	10	3.5	6	1.5	1	1
5	Alum-Rules	6		6		1	1

Notice there are several parameters available to control the suggested alternate shapes. You can define acceptable member depth and width ranges, and also code check ranges.

Design Rules – Concrete Rebar

In addition to controlling the size of your concrete members, RISA-2D also allows you to control the type of reinforcement and cover to be used.

- ◆ On the **Design Size and Code Check Parameters** spreadsheet, click the **Concrete Rebar** tab.

This spreadsheet controls the size and placement of the flexural and shear reinforcement used in the design of your concrete beams and columns.

Change the minimum bar size for **Col-Rules**:

- ◆ In row **1** (labeled **Col-Rules**), click the first cell in the **Min Flex Bar** column. Click a second time in the cell to reveal the list of options, and select **#6**.

Note: It may be helpful to lengthen the column heading to read the full column label.

Change the maximum bar size for **Conc-Bms**:

- ◆ In row **3** (labeled **Conc-Bms**), click the cell in the **Max Flex Bar** column. Click a second time in the cell to reveal the list of options, and select **#9**.

	Label	Optimize ...	Min Flex Bar	Max Flex Bar	Shea...	Legs per ...	Top (Colu...	Bottom Co...	Side Cove...	Top/Botto...	Add'l Side ...	Shear ...
1	Col-Rules	Optimize	#6	#10	#4	2	1.5	1.5	1.5	2	1	12
2	Steel-Bms	Optimize	#5	#10	#4	2	1.5	1.5	1.5	2	1	12
3	Conc-Bms	Optimize	#5	#9	#4	2	1.5	1.5	1.5	2	1	12
4	Truss-Rules	Optimize	#5	#10	#4	2	1.5	1.5	1.5	2	1	12
5	Alum-Rules	Optimize	#5	#10	#4	2	1.5	1.5	1.5	2	1	12

Note: Although rules for concrete rebar are given for each Design Rule that you have created, these rebar entries will be ignored if they are applied to anything other than concrete members.

Section Sets Spreadsheet

RISA-2D provides default section sets for each basic material type. You will now use this spreadsheet to define your new section sets. While in this spreadsheet, you will also define the section properties for the members you have defined so far.

Open the **Section Sets** spreadsheet.

- ◆ On the **Data Entry** toolbar, click **Section Sets**.

The **Section Sets** spreadsheet should look like this:

	Label	Shape	Type	Design List	Material	Design Ru...	A [in2]	I (90,270...	I (0,180)...
1	HR1A	W10X33	Beam	None	A36 Gr.36	Col-Rules	9.71	36.6	171

Section sets provide an easy way to manage members that are repetitive. This will become even more apparent when you have RISA-2D choose new and/or optimized member sizes.

So far, your truss has only nine web members. But, what if you had three trusses and were required to change the section (as you will do in *Tutorial 2*). Changing 27 member properties one at a time could take some time. By defining section sets, you will be able to globally change the truss web member properties by changing only one section on the spreadsheet.

Hot Rolled Sections and Database

You currently have one section set for each material type. Next, you will add some section sets and change the labels so that they are more useful. The active cell (denoted by green color) should contain the text **HR1**. You have not yet defined any members with this section, but you will be using it for the beams in your steel moment frame.

Give the section a more descriptive label and change the material:

- ◆ In row **1**, under the **Label** column, type **Stl-Beam**.
- ◆ Also in row **1**, Under the **Material** column, select **A992**.
- ◆ Press ENTER.

The spreadsheet should now look like this:

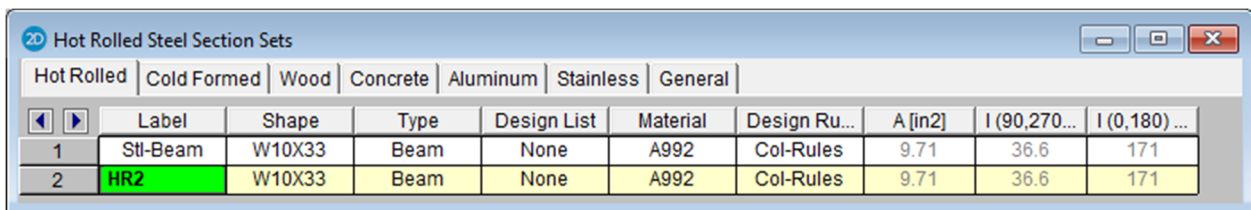

	Label	Shape	Type	Design List	Material	Design Ru...	A [in2]	I (90,270...	I (0,180) ...
1	Stl-Beam	W10X33	Beam	None	A992	Col-Rules	9.71	36.6	171
2	HR2	W10X33	Beam	None	A992	Col-Rules	9.71	36.6	171

When you press ENTER, a new row will be created (which you do not need for this model). Delete the newly created row:

- ◆ On the Window toolbar, click **Delete Line**  (now that you are in spreadsheet view, notice the Window toolbar has changed).

Notice that the Section Set data consists of a number of other entries. The **Shape** entry indicates the current size that will be used for the member. The **Type** entry indicates whether the member is a beam, column, or brace. This is especially important for the design of concrete sections.

The **Design List** and **Design Rules** entries define the list of shapes to be used and the design restrictions to impose when redesigning and/or optimizing the member. For more information on customizing design lists, refer to Appendix A in *RISA-2D General Reference*.

Finally, the **A**, **Iyy** and **Izz** columns list the area and moments of inertia for the current shape.

Modify the Design Rules:

- ◆ In row **1**, under **Design Rules**, click the cell to reveal the list of available options. Select **Steel-Bms**.

By default the current shape is a W10x33. If you know what shape you want to use, you may type it in directly. Or, if you are not sure, you may open the database and review the full list of available shapes.

Define the Hot Rolled shape:

- ◆ In row **1**, under **Shape**, click the cell to make this the active cell.

	Label	Shape	Type	Design List	Material	Design Ru...	A [in2]	I (90,270...	I (0,180) ...
1	Stl-Beam	W10X33	Beam	None	A992	Steel-Bms	9.71	36.6	171

- ◆ Click the red arrow on the right to open the **Hot Rolled** Shape Database.

The **Hot Rolled** Shape Database dialog box looks like this:

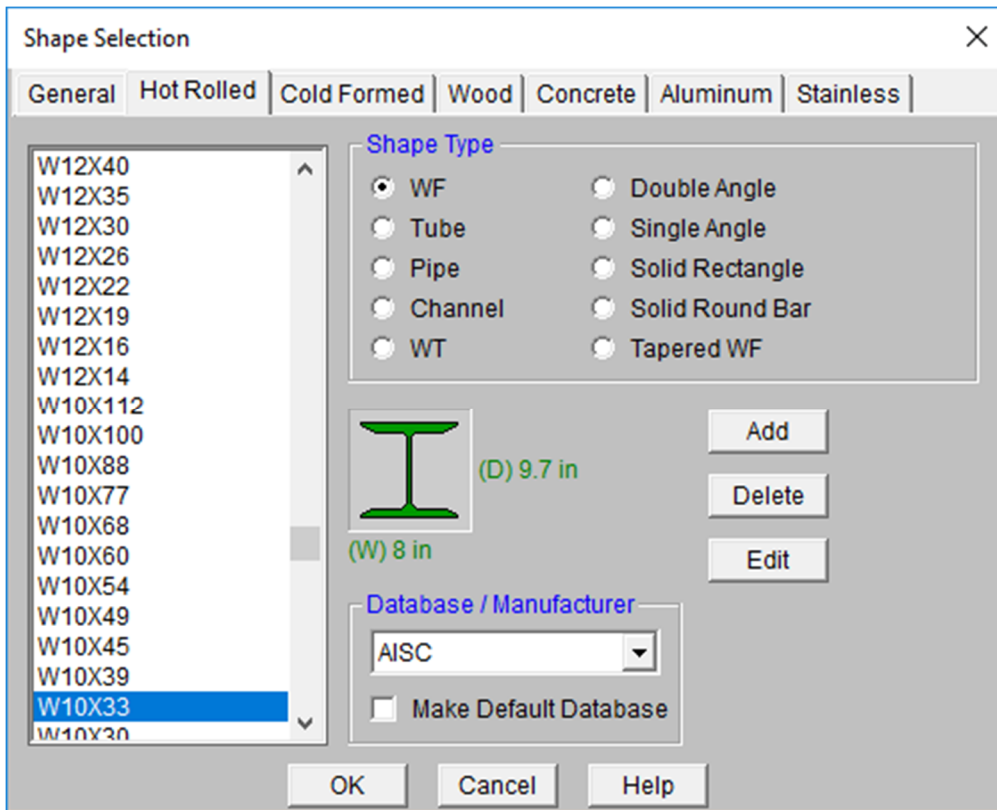

The left side of the dialog box contains a list of available shapes. The selected shape is currently W10x33. Change the shape selection:

- ◆ In the **Shape Type** list (on the left), select **W12X19**. Use the PAGE UP and PAGE DOWN keys on your keyboard to quickly move through the list.
- ◆ Click **OK** to return to the spreadsheet.

On the **Section Sets** spreadsheet, notice that **W12X19** is now in the **Shape** column. The remaining properties will be updated as soon as you leave the cell:

- ◆ Press the TAB key to advance to the next cell and update the geometric properties.

Cold Formed Sections and Database

Now, you will add your Cold Formed Section Set. Open the **Cold Formed** spreadsheet:

- ◆ On the **Section Sets** spreadsheet, click the **Cold Formed** tab.
- ◆ Under **Label**, type **Girt** to make the label more descriptive.

Your screen should now look like this:

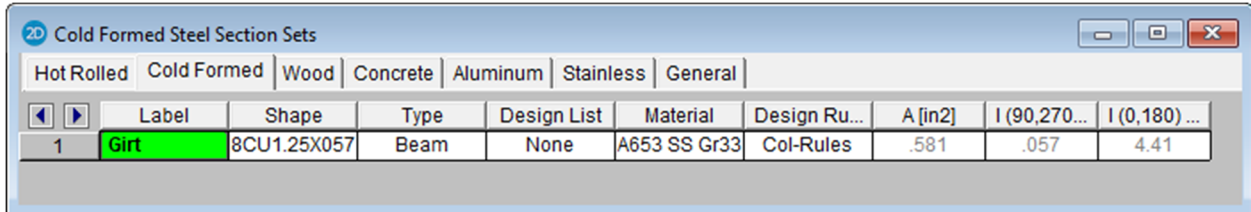

	Label	Shape	Type	Design List	Material	Design Ru...	A [in2]	I (90,270...	I (0,180)...
1	Girt	8CU1.25X057	Beam	None	A653 SS Gr33	Col-Rules	.581	.057	4.41

Once again, select your shape from the shape selection database.

- ◆ Click the first cell under the **Shape** column. Click the red arrow on the right to open the **Cold Formed** Shape Database.

The **Cold Formed** Shape Database is very similar to the Hot Rolled Shape Database, and looks like this:

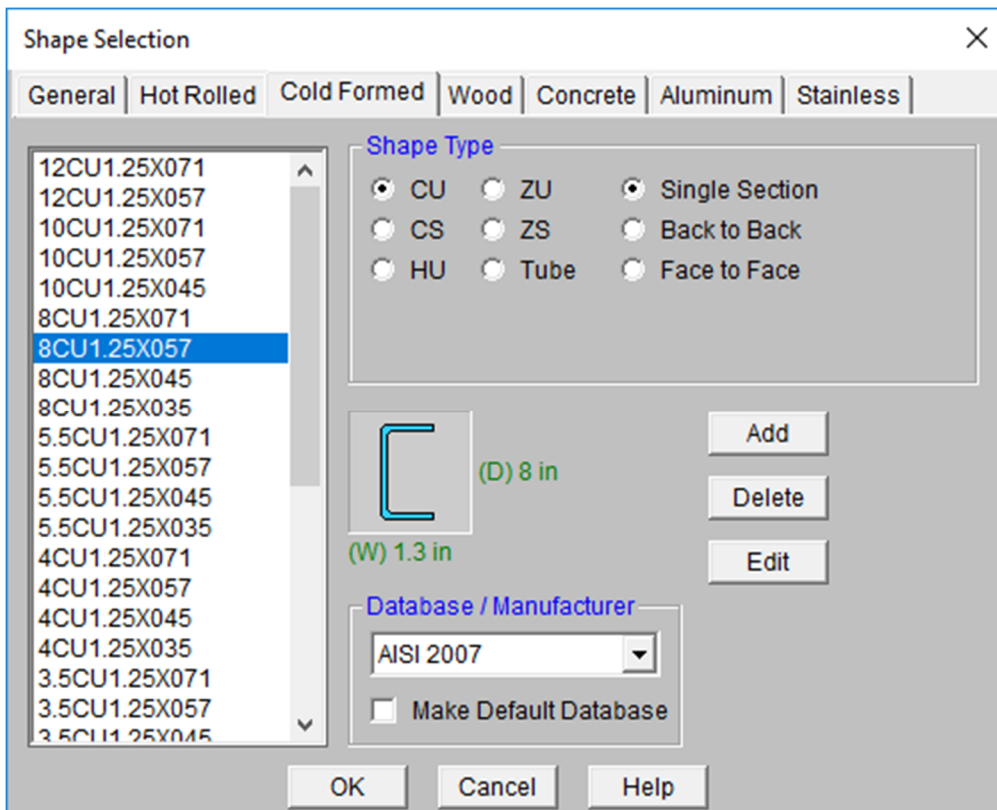

Review and modify the shape settings:

- ◆ Under **Shape Type**, click **CS**.
- ◆ Under **Database/Manufacturer**, select **AISI 2007**.
- ◆ Under the list of available shapes (on the left), select **12CS4X070**.
- ◆ Click **OK** to return to the spreadsheet.

On the Section Sets spreadsheet, notice the **A** and **I** properties will be updated as soon as you leave the cell:

- ◆ Click in the first cell under **Design List**, making this the active cell. Click the cell a second time to display the available design lists.
- ◆ Select **CS**.

This final step will ensure that when RISA-2D performs member redesign and/or optimization, it will suggest a new CS from within the appropriate parameters set in the Design Rule:

- ◆ Click in the first cell under **Design Rules** two times to display the available design lists.
- ◆ Select **Steel-Bms**.

Wood Sections and NDS Database

Moving now to wood, define the section used for the chords and webs of the wood truss.

- ◆ On the **Section Sets** spreadsheet, click the **Wood** tab.
- ◆ In row **1**, under **Label**, type **Chord**.
- ◆ Under the **Material** column, select **DFL Select**. Press ENTER to make a new row.
- ◆ In row **2**, under **Label**, type **Web**.

The spreadsheet should now look like this:

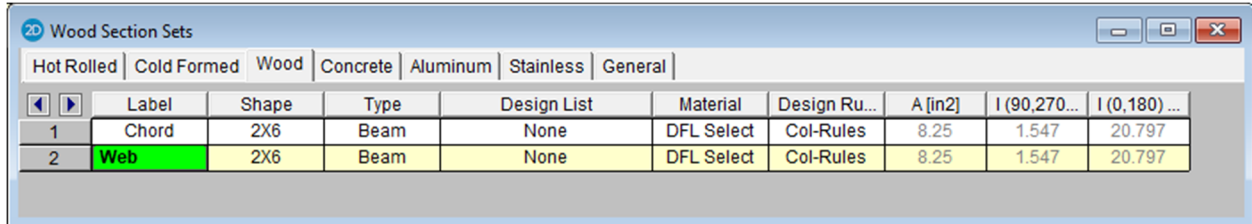

	Label	Shape	Type	Design List	Material	Design Ru...	A [in2]	I (90,270...	I (0,180) ...
1	Chord	2X6	Beam	None	DFL Select	Col-Rules	8.25	1.547	20.797
2	Web	2X6	Beam	None	DFL Select	Col-Rules	8.25	1.547	20.797

The **Shape** is currently set to **2x6** for both members. This is sufficient for the web members; but for the chords, it is preferable to use doubled members:

- ◆ In row **1**, click the first cell under the **Shape** column. Click the red arrow on the right to open the **Wood Shape Database**.
- ◆ Select **2** for the number of plies.

The dialog box should look like this:

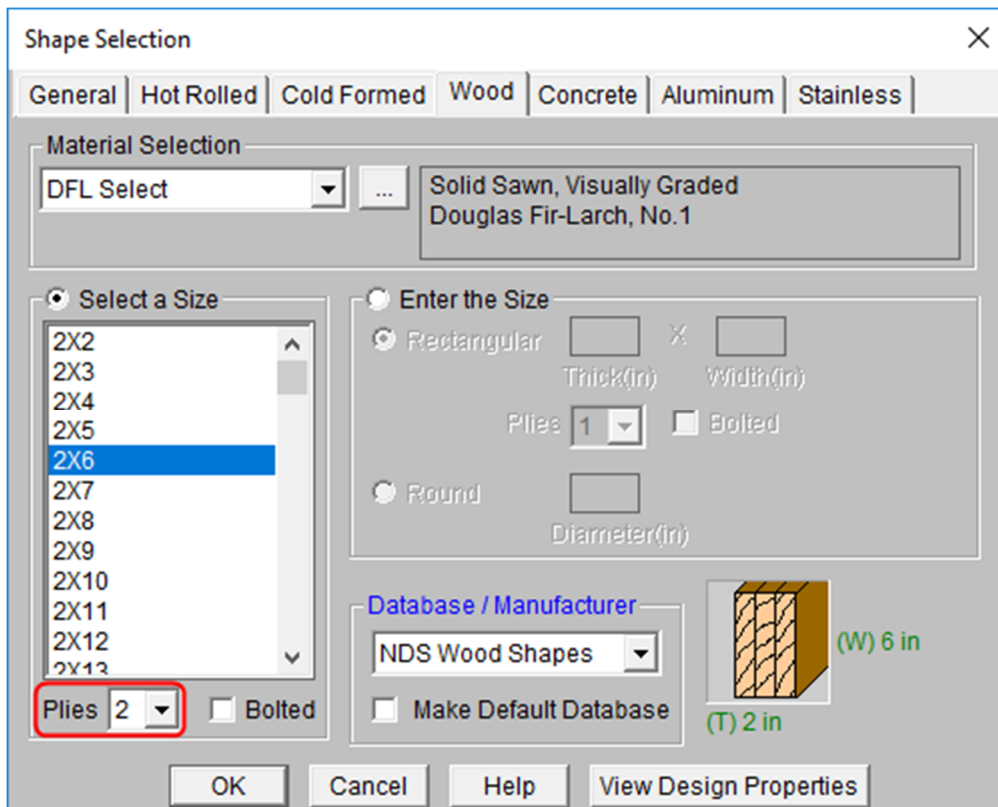

Return to the **Section Sets** spreadsheet:

- ◆ Click **OK**.

You have now changed the current shape to a double 2x6. To modify RISA-2D so that it will suggest Double Rectangles when performing member redesign and/or optimization, you must also change the Design List:

- ◆ In row **1** (labeled **Chord**), click the first cell under **Design List** two times to display the design lists.
- ◆ Select **Rectangular Double**.
- ◆ In row **2** (labeled **Web**), click the first cell under **Design List** two times to display the design lists.
- ◆ Select **Rectangular**.

This last step will ensure that the when RISA-2D performs member re-design and/or optimization, it will suggest another doubled up member for the chords. To also control the depth and thickness of the suggested shapes, modify the Design Rules.

Modify the **Design Rules**:

- ◆ In row **1** (labeled **Chord**), click the first cell under the **Design Rules** column two times to display the available design lists. Select **Truss-Rules**.
- ◆ In row **2** (labeled **Web**), click the cell under the **Design Rules** column two times to display the available design lists. Select **Truss-Rules**.

Your spreadsheet should now look like this:

2D Wood Section Sets										
Hot Rolled Cold Formed Wood Concrete Aluminum Stainless General										
	Label	Shape	Type	Design List	Material	Design Ru...	A [in2]	I (90,270...	I (0,180) ...	
1	Chord	2-2X6	Beam	Rectangular Double	DFL Select	Truss-Rules	16.5	12.375	41.594	
2	Web	2X6	Beam	Rectangular	DFL Select	Truss-Rules	8.25	1.547	20.797	

Concrete Sections

Open the **Concrete** tab:

- ◆ On the **Section Sets** spreadsheet, click the **Concrete** tab.

Take a minute to review the information listed under the **Concrete** tab. It is similar to the information in the other tabs for steel and wood.

Define the labels and the shapes:

- ◆ In row **1**, under **Label**, type **Conc-Col**.
- ◆ In row **1**, under **Shape**, type **CRECT12x12**. Press ENTER to create a new row.
- ◆ In row **2**, under **Label**, type **Conc-Bm**.
- ◆ In row **2**, under **Shape**, type **CRECT12x8**.

The spreadsheet should now look like this:

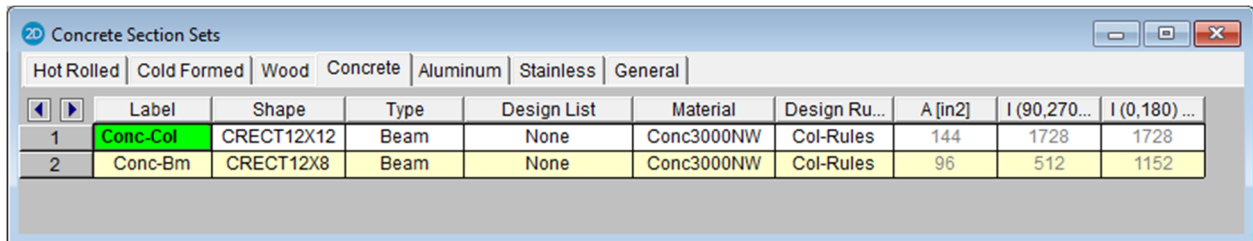

	Label	Shape	Type	Design List	Material	Design Ru...	A [in2]	I (90,270...	I (0,180) ...
1	Conc-Col	CRECT12X12	Beam	None	Conc3000NW	Col-Rules	144	1728	1728
2	Conc-Bm	CRECT12X8	Beam	None	Conc3000NW	Col-Rules	96	512	1152

Define the type and set the design list:

- ◆ In row **1**, under **Type**, click the cell two times to list the available types. Select **Column**.
- ◆ In row **1**, click the first cell under **Design List** two times to display the design lists.
- ◆ Select **Rectangular**.
- ◆ In row **2**, click the first cell under **Design List** two times to display the design lists.
- ◆ Select **Rectangular**.

Remember that your concrete reinforcing and cover information was specified as part of the **Design Rules**. This is currently set to **Col-Rules** for both sections. While this is correct for **Conc-Col**, use a different rule for the beams.

- ◆ In row **2** (labeled **Conc-Bm**), click the cell under **Design Rules** two times to display the list of available options. Click **Conc-Bms**.

Your spreadsheet should now look like this:

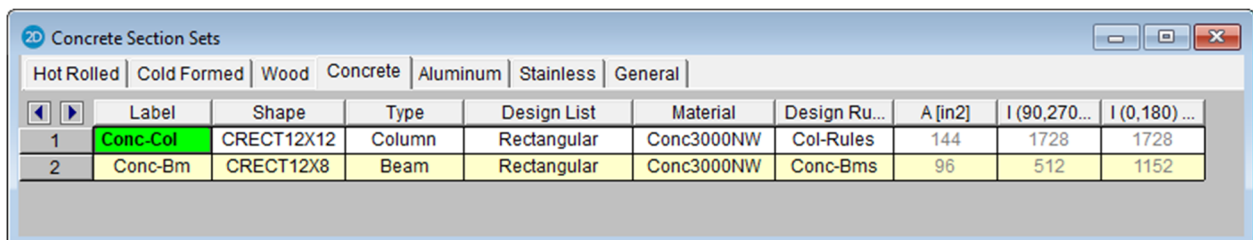

	Label	Shape	Type	Design List	Material	Design Ru...	A [in2]	I (90,270...	I (0,180) ...
1	Conc-Col	CRECT12X12	Column	Rectangular	Conc3000NW	Col-Rules	144	1728	1728
2	Conc-Bm	CRECT12X8	Beam	Rectangular	Conc3000NW	Conc-Bms	96	512	1152

Aluminum Sections

Lastly, open the **Aluminum** tab:

- ◆ On the **Section Sets** spreadsheet, click the **Aluminum** tab.

Take a minute to review the information listed under the **Aluminum** tab. It is similar to the information in the other tabs for steel and wood.

Define the shape:

- ◆ In row **1**, under **Label**, type **Alum-Bm**.
- ◆ In row **1**, click the cell under the **Shape** column. Click the red arrow on the right to open the **Aluminum** Shape Database.
- ◆ Under **Shape Type**, select **Rect Tube**.
- ◆ From the list of available shapes, select **RT6X6X0.125**.
- ◆ Click **OK** to return to the **Section Sets** spreadsheet.
- ◆ From the **Design List** menu, select **Rectangular Tubes**.
- ◆ From the **Material** menu, select **6061-T6**.
- ◆ And finally, select **Alum-Rules** from the **Design Rules** menu.

When complete your spreadsheet should look like the following:

	Label	Shape	Type	Design List	Material	Design Ru...	A [in2]	I (90,270...	I (0,180) ...
1	Alum-Bm	RT6X6X0.125	Beam	Rectangular Tubes	6061-T6	Alum-Rules	2.94	16.9	16.9

Multiple Windows

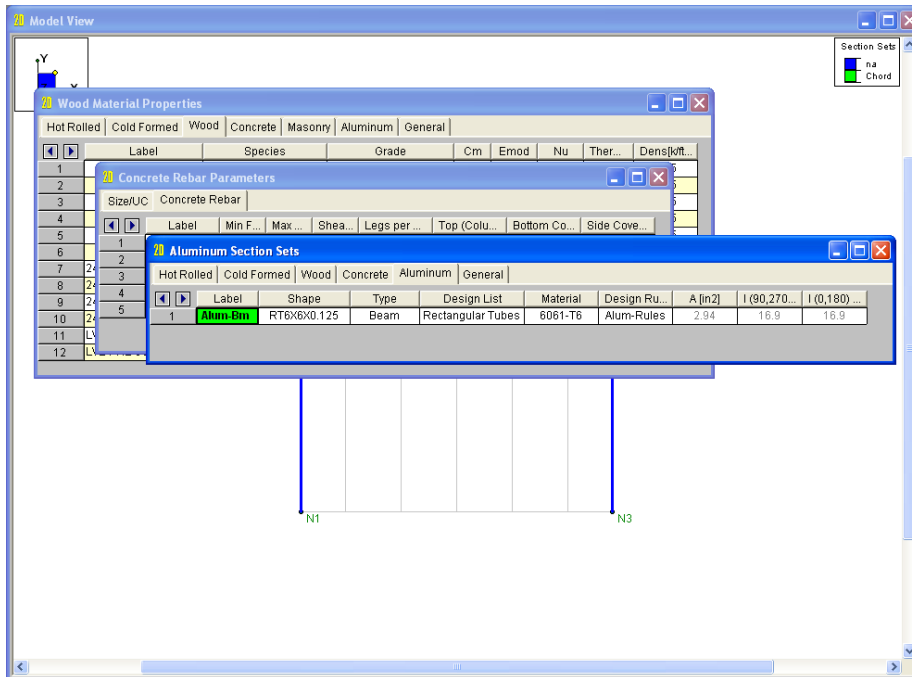

At this point, you should have a model view and three spreadsheets open and visible on your screen. Notice the “active window” is denoted by a colored title bar (in this case, the **Aluminum Section Sets** spreadsheet). The title bars of the other inactive windows are dimmed. The windows are tiled in the order that you opened them. You can return to any of the windows by clicking anywhere on them, preferably on the title bars, so you do not accidentally click a button or a grid point.

Note: To move a window, press and hold the title bar with your mouse, then drag to the desired location.

You can also access the open windows and dialog boxes through the **Window** menu. This menu allows you access to windows that may be hidden from view.

- ◆ Click the **Window** menu.

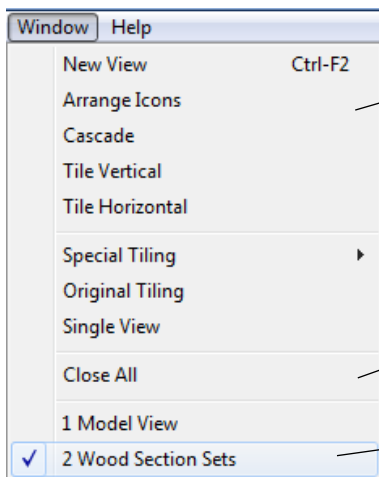

The **Window** menu presents some window arrangement and tiling options.

The open windows are listed in the order they were opened. You can select any of the open windows to make it active.

The active window is denoted by a check mark.

Change the active window to model view:

- ◆ On the **Window** menu, select **1 Model View**.

The model view becomes the active window and moves to the front of the other windows. The spreadsheets are still open beneath the model view window, but not currently visible.

You can also recall open windows the same way you originally opened them (by selecting from a menu or clicking a toolbar button). For example, to make the currently open **Section Sets** spreadsheet become the active window:

- ◆ On the **Data Entry** toolbar, click **Section Sets** to open the **Section Sets** spreadsheet.

Close the active window:

- ◆ Click **Close**  or press **CTRL+F4** to close the **Section Sets** spreadsheet.

Now, the model view should be your active window. Notice that RISA-2D resumes where you left off for all open windows. The cursor  indicates you are still in drawing mode for web members, so open the **Draw Members** dialog box and change the settings so that you can now draw the crossbeam:

- ◆ Press **CTRL+D** to recall the **Draw Members** dialog box.
- ◆ Under **Member Material Type and Shape**, click **Hot Rolled**.
- ◆ Click **Assign a Section Set**. On the list of available section sets, click **Stl-Beam** (if it is not already selected).
- ◆ Under **Release Codes**, click **Fully Fixed at Both Ends**.
- ◆ Under **Release Codes**, click **Fully Fixed at Both Ends**.

When you are finished, your screen should look like this:



Tutorial 1 - Modeling

Exit the dialog box and return to the model view:

- ◆ Click **Apply**.

Begin drawing the cross beams:

- ◆ Draw members from point **A** to point **B** using the grid locations shown below.
- ◆ Click the right mouse button or press ESC to release the mouse.

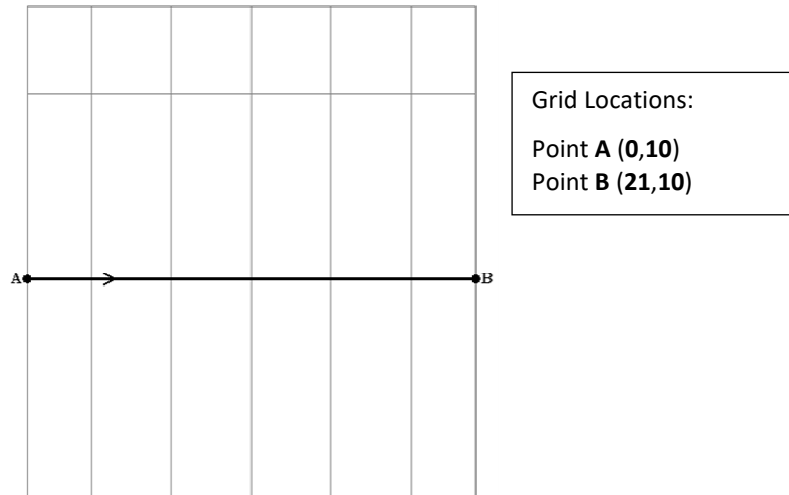

Your image should now look like this:

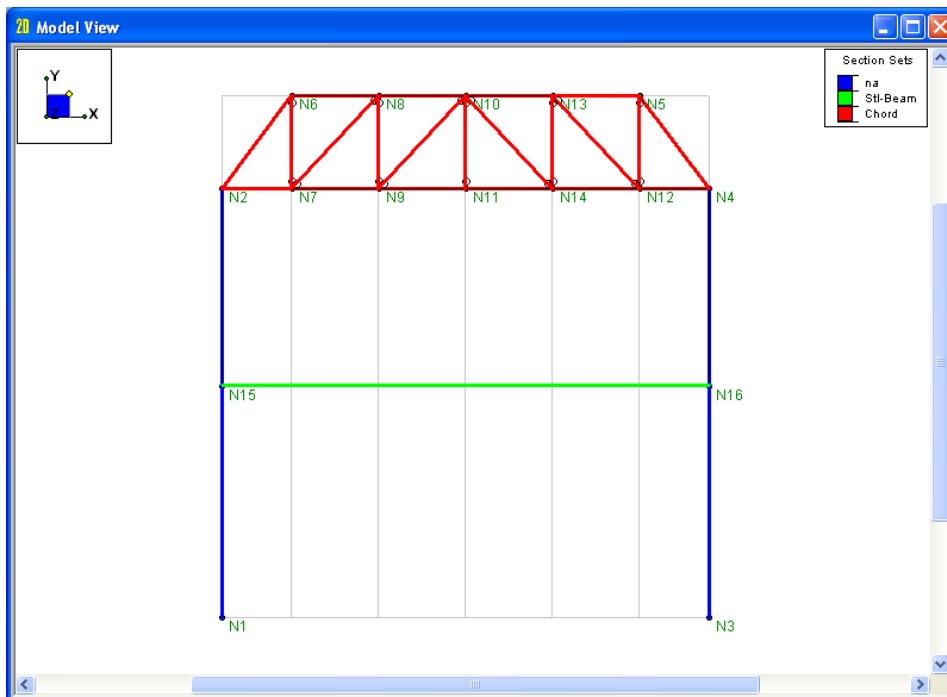

Entering Spreadsheet Data

In addition to its graphical editing features, RISA-2D allows you to add, organize or sort your data using a series of powerful spreadsheets.

Explore the **Joint Coordinates** spreadsheet:

- ◆ Click the **Spreadsheets** menu. Click **Joint Coordinates**.

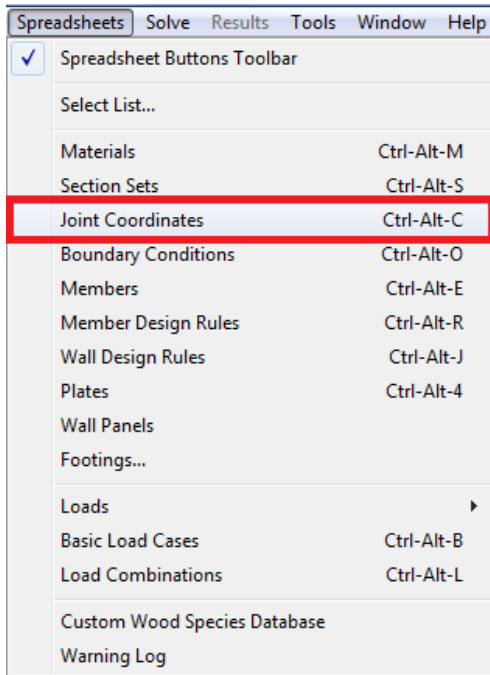

The **Joint Coordinates** spreadsheet will display:

	Label	X [ft]	Y [ft]	Temp [F]
1	N1	0	0	0
2	N2	0	18.5	0
3	N3	21	0	0
4	N4	21	18.5	0
5	N5	18	22.5	0
6	N6	3	22.5	0
7	N7	3	18.5	0
8	N8	6.75	22.5	0
9	N9	6.75	18.5	0
10	N10	10.5	22.5	0
11	N11	10.5	18.5	0
12	N12	18	18.5	0
13	N13	14.25	22.5	0
14	N14	14.25	18.5	0
15	N15	0	10	0
16	N16	21	10	0

Tutorial 1 - Modeling

Next, you will be adding a lower concrete frame and masonry shear wall to support the rest of your structure. You could modify the grid to help you draw in the new elements, but instead, you will use the spreadsheets to manually enter the additional joints that define the base of the frame.

Create a new row in the spreadsheet:

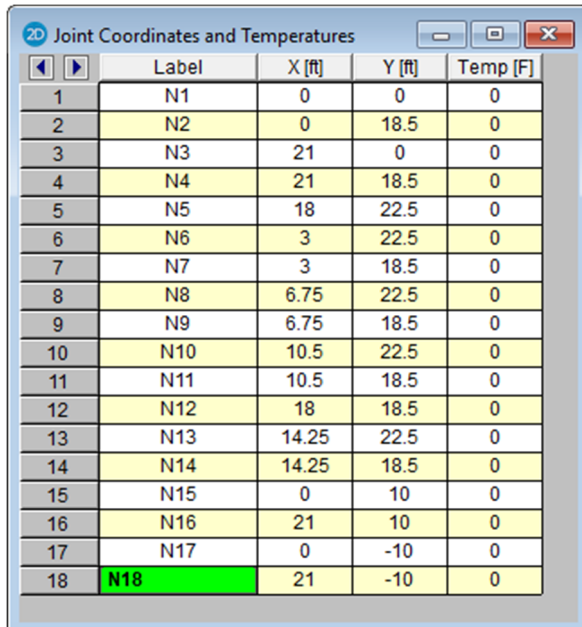

- ◆ In row **16**, click **N16**. Press the ENTER key to create a new row.
- ◆ In row **17**, under the **Y** column, type **-10**. Press the ENTER key to create another new row.
- ◆ In row **18**, under the **X** column, type **21**. Under the **Y** column, type **-10**.

Your image should now look like this:



	Label	X [ft]	Y [ft]	Temp [F]
1	N1	0	0	0
2	N2	0	18.5	0
3	N3	21	0	0
4	N4	21	18.5	0
5	N5	18	22.5	0
6	N6	3	22.5	0
7	N7	3	18.5	0
8	N8	6.75	22.5	0
9	N9	6.75	18.5	0
10	N10	10.5	22.5	0
11	N11	10.5	18.5	0
12	N12	18	18.5	0
13	N13	14.25	22.5	0
14	N14	14.25	18.5	0
15	N15	0	10	0
16	N16	21	10	0
17	N17	0	-10	0
18	N18	21	-10	0

You have now finished adding all the joints necessary for this tutorial. Close the spreadsheet and return to the model view to continue drawing members (the spreadsheets will be covered more in *Tutorials 2* and *3*):

- ◆ Click **Close**  to close the spreadsheet.
- ◆ On the Window toolbar, click **Redraw**  to redraw the full model view.

The new joints you created should now be visible below the existing columns.

Drawing Concrete Members

Open the **Draw Members** dialog box again:

- ◆ Press **CTRL+D** to reopen the **Draw Members** dialog box.

Notice that the dialog box retained the properties you entered when drawing your steel cross beam. Modify it now to be consistent with the new concrete member that you are going to enter.

- ◆ Under **Member Material Type and Shape**, click **Concrete**.
- ◆ Then, click **Assign a Section Set**. On the list of available section sets, click **Conc-Col** (if it is not already selected).

When you are finished, the dialog box should look like this:

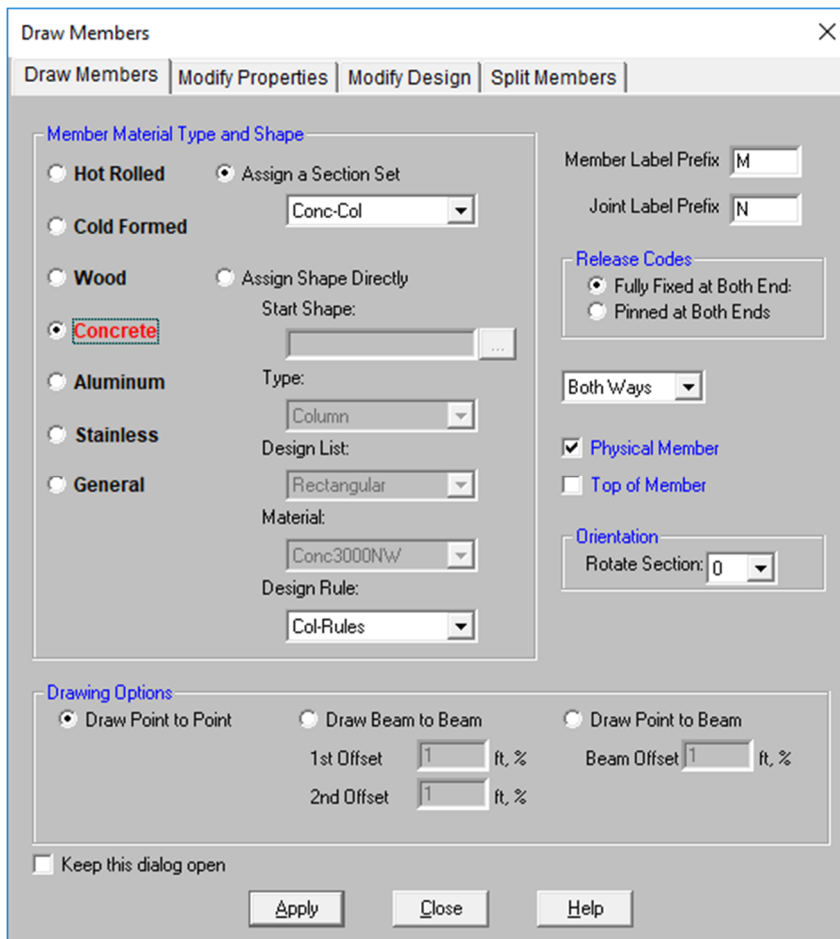

Exit the dialog box and resume drawing:

- ◆ Click **Apply**.

Tutorial 1 - Modeling

Next, draw in the new members:

- ◆ First, click joint **N17** and then **N1**.

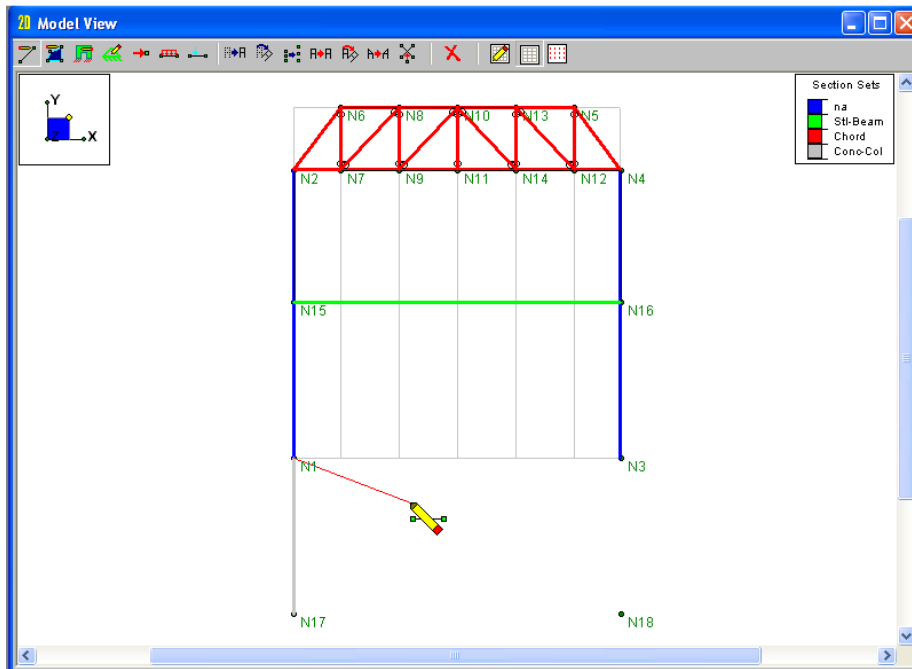

- ◆ Next, click on joint **N3** and finally **N18**.
- ◆ Right click to release the drawing tool.

This will create a new vertical member from N17 to N1, a new horizontal member from N1 to N3, and a new vertical member from N3 to N18.

Your screen should now look this:

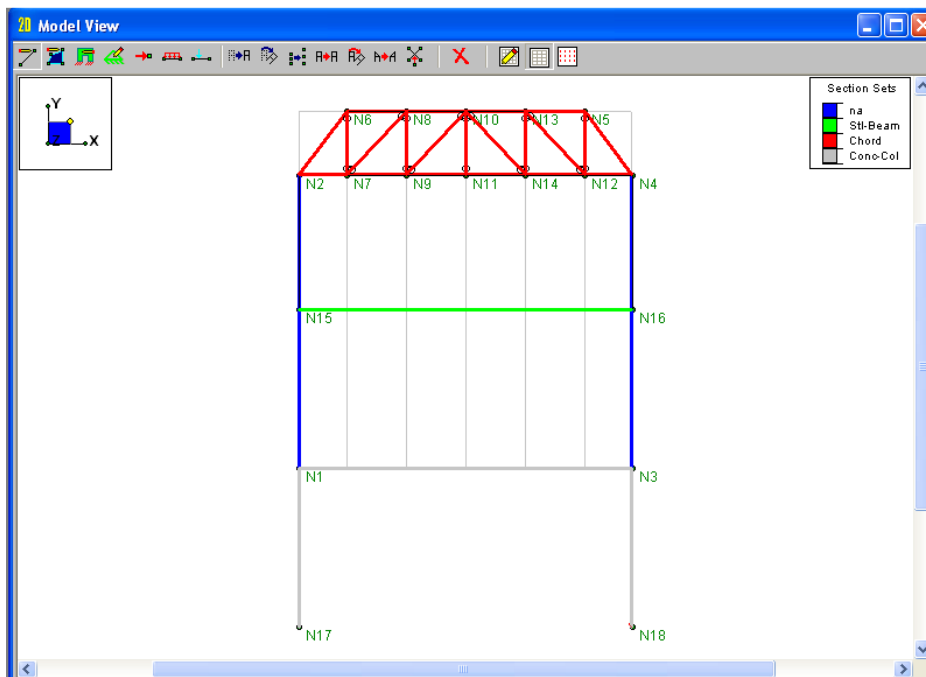

Boundary Conditions

Boundary conditions define how the model is constrained. All models must be attached to some external point(s) of support (otherwise an error message will display notifying you that your model is unstable).

Prepare to add boundary conditions at the base of the columns:

- ◆ On the Drawing toolbar, click **Boundary Conditions** .

This dialog box will display:

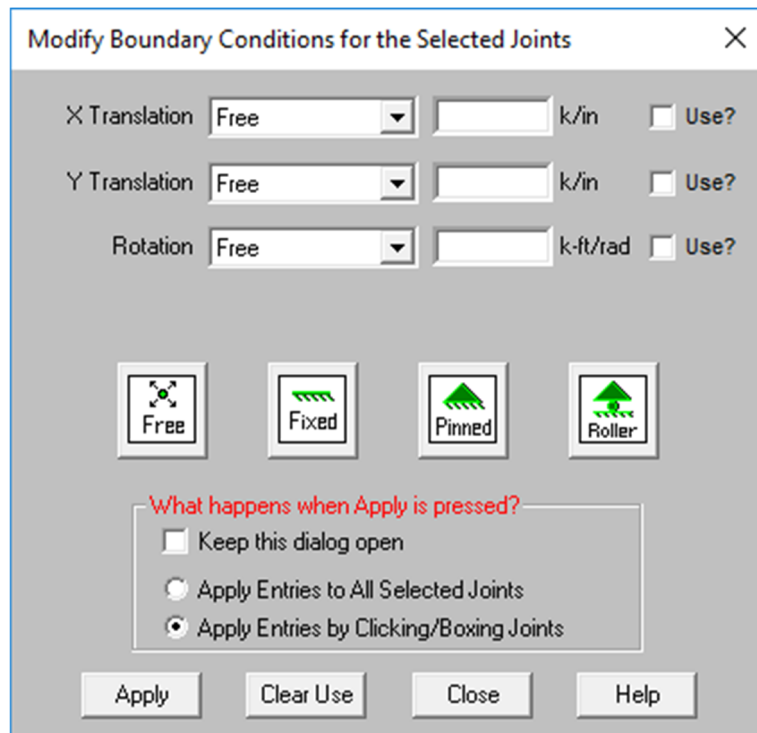

Boundary conditions can be applied to any joint. There are three degrees of freedom for each joint; therefore, there are three parameters provided; one for each direction.

Tutorial 1 - Modeling

Review the options for assigning boundary conditions. Each option is described below:

- ◆ In the **X Translation** list, click the down arrow to see the available boundary condition options.



Free	No restraint.
Reaction	Specifies full restraint for the indicated direction. No movement will be allowed in the indicated direction for this joint. A reaction force will be calculated and reported.
Fixed	Similar to Reaction, this option also specifies full restraint for the joint in the indicated direction; however, no reaction force is calculated. This setting actually removes the degree of freedom from the solution. If you are not interested in reactions, using this option will result in a slightly smaller model.
Spring	This option models a spring attached to the joint in the indicated direction and must be accompanied by a spring stiffness. The units for the spring stiffness depend on whether the spring is translational or rotational and are displayed next to the edit box. For example, to specify a spring of stiffness 100 kips per inch, select Spring from the list and type 100 in the adjacent box.
Compression Spring	This option models a compression-only spring and must be accompanied by a spring stiffness. This type of spring will only resist compression (negative displacement); if a tension force (positive displacement) is applied to it, it will release and provide no resistance.
Tension Spring	This option models a tension-only spring and must be accompanied by a spring stiffness. This type of spring will only resist tension (positive displacements); if a compression force (negative displacement) is applied to it, it will release and provide no resistance.
Slave	This option “slaves” the degree of freedom of one joint to another that you specify.

Next, specify pin supports at the base of your columns. For this tutorial, the X and Y translations will be restrained, but the rotation will be unrestrained. This is a common boundary condition that is built in to RISA-2D, and can be applied as shown below:

- ◆ Click the **Pinned** button and the boundary condition settings described above will be completed for you.

The dialog box should now look like this:

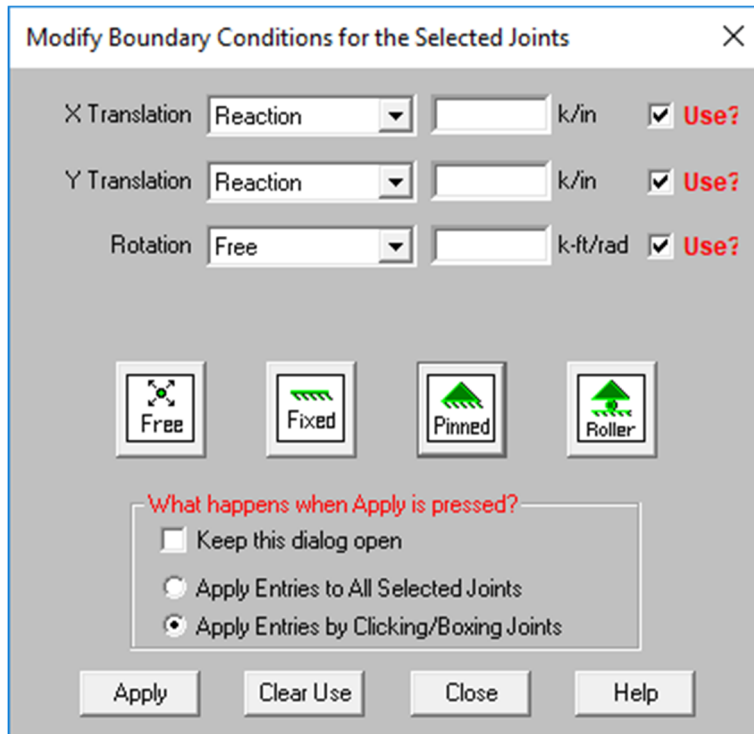

The **Use?** check boxes must be selected for a modification to be applied. This allows you to change a condition for just one of the parameters, instead of requiring all three to match.

Finish your selections and close the dialog box:

- ◆ Under **What happens when Apply is pressed?**, select **Apply Entries by Clicking/Boxing Joints** (this important feature will be discussed in more detail later).
- ◆ Click **Apply**.

Note: Your cursor will change to  , indicating you are ready to apply the boundary condition when you click any joint.

Apply the boundary condition to the base of both columns at joints N17 and N18.

- ◆ Click joint **N17** and then on joint **N18**.

Tutorial 1 – Modeling

Your model should now look like this:

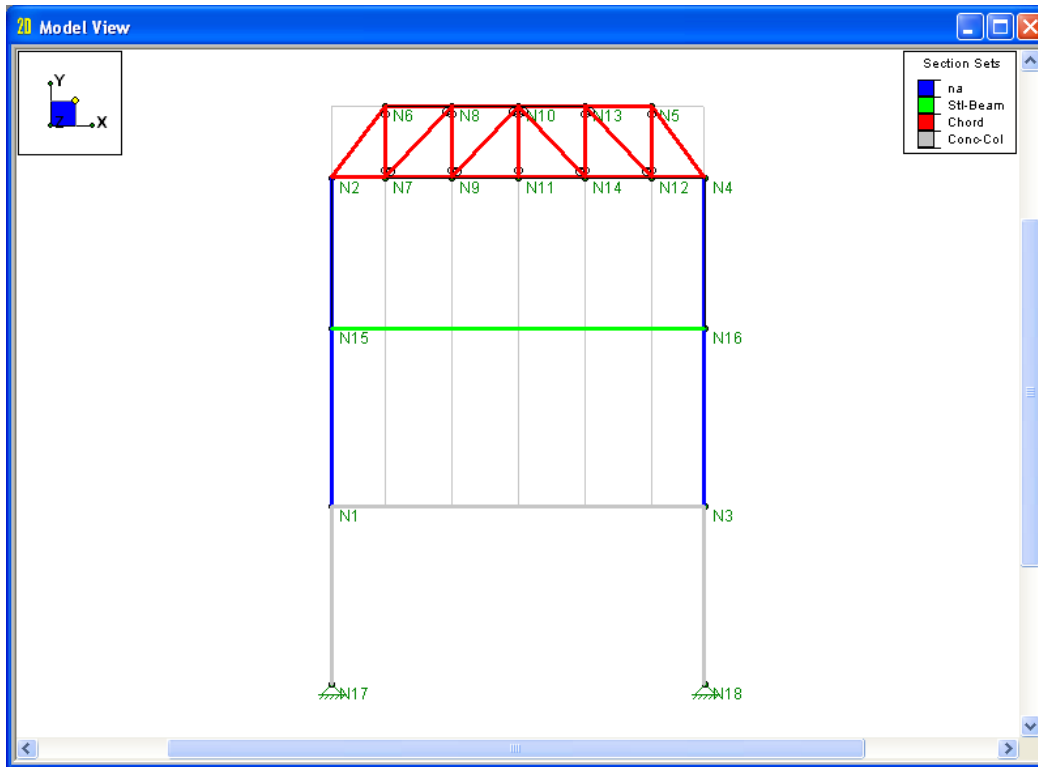

Review how the boundary condition data you just entered graphically was recorded on the **Boundary Conditions** spreadsheet:

- ◆ On the **Data Entry** toolbar, click **Boundary Conditions** to open the spreadsheet.

	Joint Label	X [k/in]	Y [k/in]	Rotation [k-ft/rad]
1	N17	Reaction	Reaction	
2	N18	Reaction	Reaction	

RISA-2D allows you to edit existing boundary conditions here, or add new ones. To add a new boundary condition, you would simply type directly on the spreadsheet (you can type just the first letter such as “R” for Reaction, then press ENTER). Or, you can click the red arrow to view the available options.

This is the end of Tutorial 1. The next tutorial demonstrates how to make modifications to the model.

You may save your model to be used as the starting point for the next tutorial, or begin the next tutorial using the .r2d starter file in the RISA-2D **Tutorials** folder. To save the model:



- ◆ Select **Save As** from the **File** menu. Enter in a file name and click **Save**.

Tutorial 2 – Modifying





Overview

In this tutorial, you will modify the 2D frame you defined in the last tutorial and use RISA-2D's graphic editing features to expand it into a two-bay frame. This tutorial continues where the previous tutorial ended, so follow these steps to get your model up and running:

If you are continuing from the previous tutorial:

- ◆ From the **Window** menu, select **Single View**.
- ◆ On the Window toolbar, click the **Graphic Editing Toolbar** button  to activate the Drawing toolbar.
- ◆ On the **Data Entry** toolbar, click **Close**  to close it.
- ◆ Skip ahead to the next page.

-OR- If you are starting here from scratch, follow the steps below to load the starter file provided by RISA Technologies:

- ◆ Double-click the **RISA-2D** icon to start the program. The **Starting a Model** dialog box will display.
- ◆ Click **Open Model** . Double-click the **Tutorials** folder, select **RISA-2D Tutorial 2 Starter.r2d** and click **Open**.
- ◆ Click **Close**  (or **Cancel**) to exit the **(Global) Model Settings** dialog box.
- ◆ On the Window toolbar, click the **Graphic Editing Toolbar** button  to activate the Drawing toolbar.
- ◆ On the **Data Entry** toolbar, click **Close**  to close it.

Your screen should look like this:

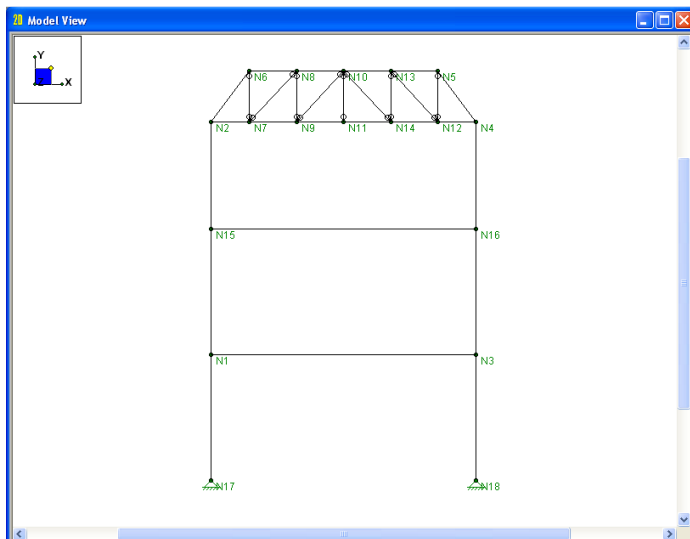

Tutorial 2 – Modifying

To get started, you will modify the end conditions at the tops of the columns. Notice that the web members of the truss are pinned at the ends (indicated by the circle at the end of each member). All other members are fixed at the end. You will modify the column top ends so that they are pinned as well.

Modifying an Item

RISA-2D provides a quick and easy way to view and edit properties of any item in the model. You may simply double-click any joint, member, or plate to view and edit all of the information for that item.

- ◆ Double-click the left steel column (anywhere between **N1** and **N2**).

This dialog box will display:

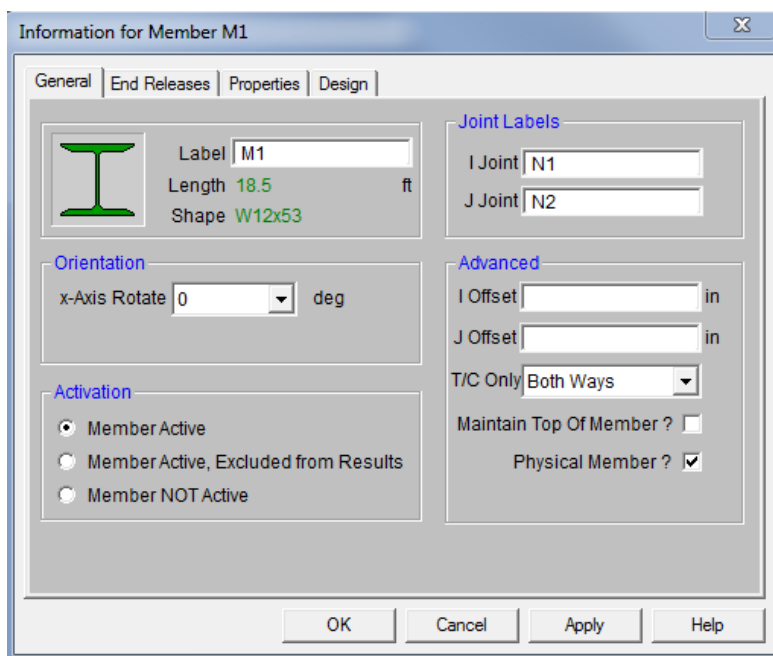

Select each tab as follows:

- ◆ Click the **Properties** and **Design** tabs to preview the different methods for adding or editing member information.

Modify the end releases for the first column:

- ◆ Click the **End Releases** tab.
- ◆ Under **J End Release Codes**, click **Pinned**.
- ◆ Click **OK** to close the dialog box and return to the model view.

Next, define the end releases for the right column:

- ◆ Double-click the steel column on the right (anywhere between **N3** and **N4**) to open this column's information dialog box.
- ◆ Click the **End Releases** tab.
- ◆ Under **J End Release Codes**, click **Pinned**.
- ◆ Click **OK** to close the dialog box.

Notice pins should now be visible at the tops of the columns.

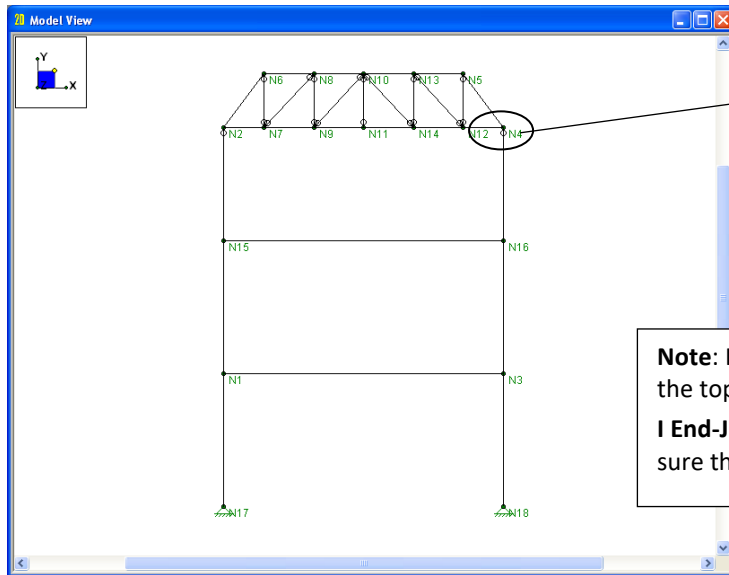

The open circles at the top of each column represent pin end releases.

Note: If you do not see the open circles at the top of each column, click the **I End-J End** button  a few times to make sure the I-J end flags are on.

Before proceeding, inspect one of the joints:

- ◆ Double-click the bottom left joint (**N17**) to review the information.
- ◆ Click **Cancel** to close the dialog box without making any changes.

Note: This method of reviewing and editing model information is sufficient when modifying one or two items in your model. However, to modify several members at once, it is easier and more efficient to use the graphical selection and editing tools, described next.

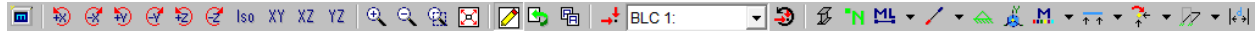

Editing the Model View

This section explains how to modify the model view using the graphical selection and editing tools. Since you are currently working in a model view the Window toolbar will look like this:



The first button on the left is the **Model Display Options** button  (used earlier to color the members). This will be explained in more detail later.

Rotating the Model

The **Rotate** buttons  are used to rotate the model counter-clockwise or clockwise about the Global Axes. The **View** buttons  are used to “snap” the view to the default isometric view, or the XY, YZ, or XZ planar view, respectively.

- ◆ On the Window toolbar, click some of the **Rotate** and **View** buttons (shown above) and experiment with rotating and snapping the plot to different views.

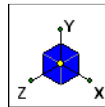

As you click the **Rotate** and **View** buttons, notice the direction the plot is rotating. It may help to reference the Global Axes icon at the top left corner of your model that looks like this:



When you are finished experimenting, place the model in an isometric view:

- ◆ On the Window toolbar, click **Isometric** .

Zooming the Model

The **Zoom** buttons are used to zoom the model view in and out. The first two **Zoom In**  and **Zoom Out**  of the model as a whole. The third, **Box Zoom** , allows you to zoom in on a specific area of interest. Try the box zoom now:

- ◆ On the Window toolbar, click **Box Zoom** , then box any area in your model by pressing and dragging your mouse. Release the mouse.

If your mouse has a wheel, you will also be able to zoom using the mouse wheel:

- ◆ Roll the mouse wheel forward and backward a few times to see the zooming effect.
- ◆ On the Window toolbar, click **Redraw**  to redraw the model within your window.

Panning the Model

With the mouse wheel, you will also be able to use RISA-2D’s panning feature:

- ◆ Simply press down the mouse wheel anywhere on your model, then hold and drag to the desired location. This will drag your model to the new location.

When you are finished, return to your original, full model view:

- ◆ On the Window toolbar, click **Planar XY** , then **Redraw** .

Edit Using the Drawing Toolbar

The **Graphic Editing**  button is used to turn the Drawing toolbar on and off in the current model view.



- ◆ On the Window toolbar, click **Graphic Editing**  a few times. Notice the Drawing toolbar will turn on or off each time. When finished, leave the Drawing toolbar on.

Saving Views

If you create a customized view that you think you may use again, you can save it for future recall using the **Save or Recall View** button . (It may even be a good idea to use this feature whenever you create a view that takes some time.) Simply click the **Save or Recall View** button and assign a name to the saved view. All of the Model Display Options will be recorded and saved for later recall.

Multiple Views

RISA-2D provides the ability to display multiple views of your model using two powerful tools:

Clone View  and **New Model View** . These tools allow you to keep your original model view (window) intact in one view, then create additional views to display different views of the model.

Clone View - opens a new window containing the current model view (*including* any rendering or viewing changes you have made).

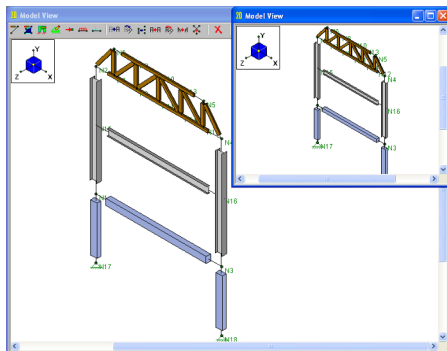

Example 1. Notice the current model view is in ISO view and rendered--the cloned view is identical.

New Model View - opens a new window containing the current model view (but does not include any rendering or view modifications).

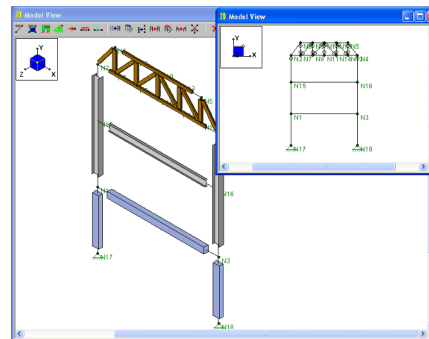

Example 2. Even though the original model view is rendered and in ISO view, the New Model View opens in wireframe, Planar XY view (the RISA-2D default view).

Listed below are some scenarios in which you may want to use these tools:

- To isolate specific parts of your model to see how those parts are affected by your modifications.
- If you do not want to change your existing view, but need to view a different side of the model, simply open a new window to view the other side.
- When viewing results, you can plot different results information in each view.











Note: Each view, whether created with **Clone View** or **New Model View**, is independent and can be rotated, rendered, zoomed, selected, etc., without affecting the other model views. However, any modeling changes you make in any view will be automatically updated in the other views.

Load Viewing Operations

Load viewing functionality is provided to help you display and switch the loads. This will be discussed in more detail after your loads are defined.

Remaining Viewing Buttons

The remaining toolbar buttons control identifying information in the model view. On the Window toolbar:

- ◆ Click **Rendering**  twice to turn on model rendering (discussed in further detail later).
- ◆ Click **Joint Labels**  three times to view the joint label options.
- ◆ Click **Member Labels**  to turn on the member labels.
- ◆ Click **I End-J End**  three times to view the I-J end flag viewing options.
- ◆ Click **Boundary Conditions**  a couple times to toggle the boundaries on and off.
- ◆ Click **Global Axes**  a couple times to toggle the Global Axes icon on and off.
- ◆ Click **Member Color Basis**  a couple of times to toggle the unity (bending) display.
- ◆ Click **Show Member Results**  to turn on results display.
- ◆ Click **Reactions-Moments**  three times to display the moments.
- ◆ Click **Deflected Shape**  to turn on the deflected shape with undeflected shadow.
- ◆ Click **Distance Tool**  to enable the measuring tool.

Model Display Options

The **Model Display Options** dialog box controls what is displayed on the plot.

- ◆ On the Window toolbar, click **Model Display Options** .
- ◆ Click the **Members** tab. Click the down arrow next to each list to view the available Model Display Options.

When finished reviewing this dialog:

- ◆ Choose the **Color Coded** option and select **Section Set** as the **Color Basis**. Click **OK** to close the dialog and return to our model view.

Note: You may make any Model Display Options your default options by clicking the **Save as Defaults** button on the **Misc** tab.

Selection Tools

Selection tools are necessary to identify and isolate specific parts of the model.

Note: Currently, your cursor looks like this , indicating you are in the default selection mode. While in this mode, click any item to select or unselect it.

Selected items appear in wireframe, color fill, or rendered view (depending on your **Model Display Options** selection). Unselected items appear as grey wireframe lines. Next, compare the two.

Currently, all elements in your model are selected. Unselect the crossbeam:

- ◆ Click the steel crossbeam (between **N15** and **N16**) to unselect it. The color fill beam will become light grey in color, denoting that it is now unselected.

Your model should now look like this:

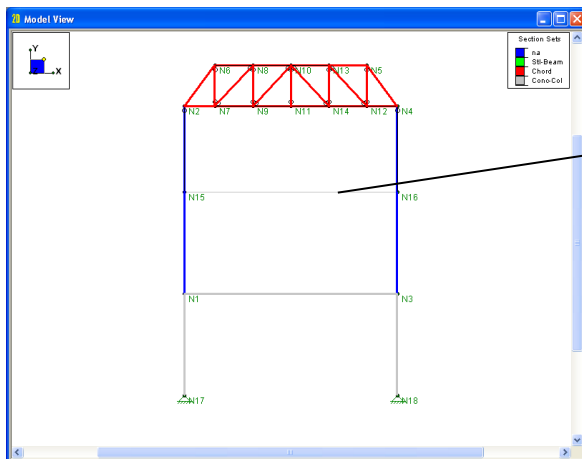

The crossbeam is now unselected.

Experiment with selecting and unselecting members and joint locations, and viewing information on them.

- ◆ Click a few of the lines and joints to see how the elements can be unselected, and then again to select them.

Using the Selection Toolbar to Make Selections



Rather than clicking to select one item at a time, you may use RISA-2D's Selection toolbar to help you quickly achieve any selection you want.





















The Selection toolbar is the vertical toolbar along the left side of the screen.

It provides selection tools to help you work with parts of the model. The toolbar is visible when your model is the active window (it will not be visible when working on a spreadsheet).

Experiment with making selections using the selection tools. Feel free to try all of them as you cannot affect the model solely by selecting items.

Note: When using the select and unselect tools, the cursor will remain in that selection tool mode so that you can make multiple selections. To terminate the chosen selection mode, click the right mouse button.

The selection tools are described below:

	<p>Select All  and Unselect All </p> <p>Select/unselect the entire model.</p>
	<p>Box Select  and Box Unselect </p> <p>Draw a box around the part to be selected/unselected. Only items that are <i>entirely</i> in the box will be affected.</p>
	<p>Polygon Select  and Polygon Unselect </p> <p>Draw a polygon around the part to be selected/unselected (double click to end). When you have finished drawing the polygon, double click to complete the selection.</p>
	<p>Line Select  and Line Unselect </p> <p>Draw a line through all items to be selected or unselected. Simply click the mouse to begin drawing the line, drag to draw the line, then release the mouse to complete the selection. This tool is ideal for selecting the columns or web members in a truss.</p>
	<p>Invert Selected </p> <p>Used to invert, or reverse, the selected state of the model. All selected items are made unselected, and all unselected items are made selected. This can be <i>very</i> useful when just a few items are to be selected in a large model; just click to unselect the items, then click Invert Selected to invert (or “flip”) the selection.</p>
	<p>Criteria Selection </p> <p>Allows you to use other criteria to make your selections. Using the Select Items for Current View dialog box, you can: (1) Select items between defined coordinates; (2) Select items using their labels, such as all joints from N7 to N15; (3) Select members by defining multiple types of criteria such as orientation, section set, database shape, and material; and (4) Select plates by defining material, thickness, and orientation.</p>
	<p>Save/Recall Selection </p> <p>Save or recall selection states of the model. If the model is altered after a selection state has been saved, the saved selection state will also be altered. After saving a selection state, any new items (joints, members, etc.) will be set to “selected.”</p> <p>To save a selection state, click Save and provide a name for the saved selection. You can have up to 16 different saved selections in a model. To retrieve a saved selection, choose the selection state from the list and click Retrieve. To delete a saved selection, choose the selection state from the list and click Delete.</p>
	<p>Lock Unselected (unlocked) and (locked)</p> <p>Lock all currently unselected parts of the model. When Lock Unselected is pressed, this selection tool changes to . When locked, all unselected parts of the model will remain unselected and invisible--no matter what other selection buttons are pressed.</p> <p>To turn the lock off, press Lock Unselected a second time (returning it to the unlocked position .</p>



When you are finished experimenting with the selection tools:

- ◆ Ensure that the **Lock Unselected** button is unlocked .



Now that you have explored the various selection tools, use them to define and modify the model.

Making Changes to Selections

Unselect the entire model and change the viewing plane:

- ◆ On the Selection toolbar, click **Unselect All**  to unselect the entire model.
- ◆ On the Window toolbar, click **XY Planar**  to change the model view to an XY elevation. Then click **Redraw**  to maximize the viewing plane.

Make some selections using the **Line Select** button:

- ◆ On the Selection toolbar, click **Line Select** . Your cursor will change to , indicating that you are now in the line selection mode.
- ◆ Draw a line through the truss web members, as shown below. Click your mouse to begin drawing the line near the leftmost truss web member, and drag past the rightmost web member, then release the mouse.

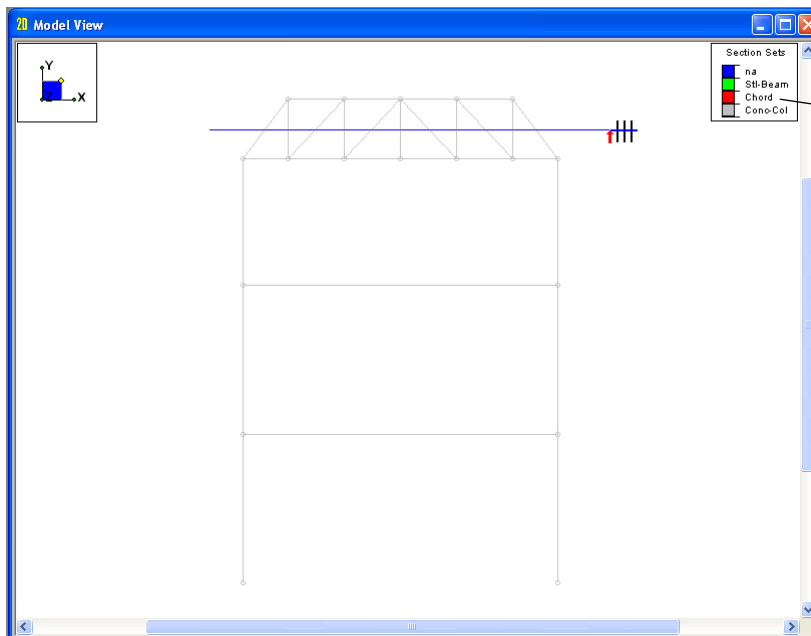

Notice that the section set for all of your web members is listed as “Chord.” This is because there was only one wood section set available when you first drew your truss.

All of the truss web members should now be selected. In the next section, you will use the current selection state to easily modify these members.

Modify Members

In this section, you will use the **Modify** tools to edit your model.

- ◆ On the Drawing toolbar, click **Draw New Members** .
- ◆ Click the **Modify Properties** tab.

Note: Each section of the dialog box contains a **Use?** check box. Selecting any of these **Use?** check boxes determines whether or not the parameter will be applied.

This dialog box looks similar to the **Draw Members** dialog box because, after the members are drawn, this dialog box allows you to change any of those initial parameters.

- ◆ Under **Member Material Type and Shape**, click **Wood**.
- ◆ Click **Assign a Section Set**, and select **Web**.
- ◆ At the top of the **Member Material Type and Shape** section, select the **Use?** check box. Once selected, the text will turn red.
- ◆ Under **What Happens when Apply is pressed?** click **Apply Entries to All Selected Members**.

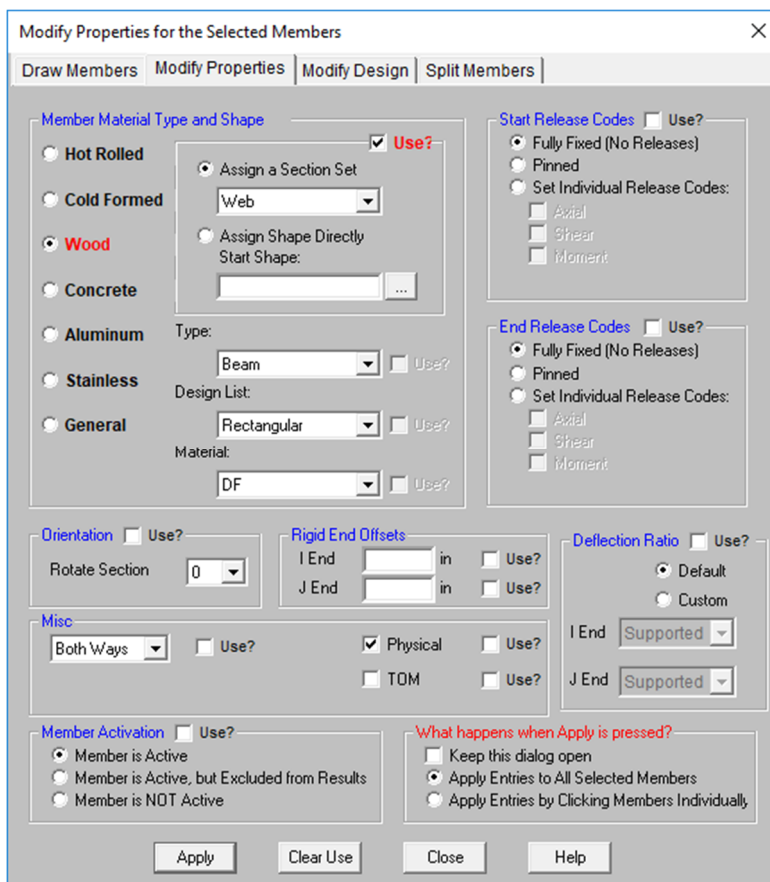

The dialog box should now look like this:



Apply the changes and close the dialog box:

- ◆ Click **Apply**.

Modify the section set for all of the selected members:

- ◆ On the Selection toolbar, click **Select All**  to select the entire model.
- ◆ On the Window toolbar, click **Isometric**  to display an isometric view of the entire structure.

Your model should now look like this:

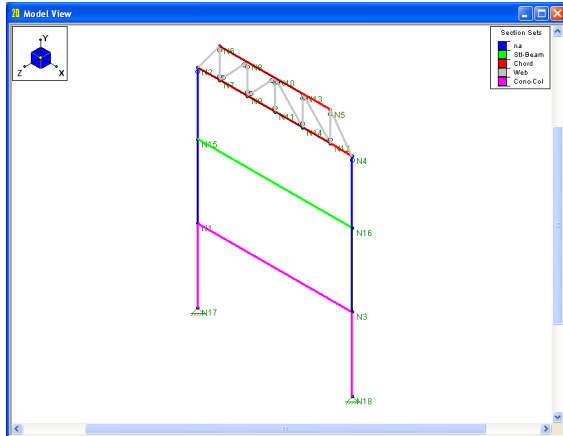

Notice that your concrete cross beam is defined with the same section set as the columns. Next, you will change this to the Conc-Bm section you created in *Tutorial 1*.

Open the **Information** dialog box:

- ◆ Double-click the concrete beam (the lower beam between **N1** and **N3**). The **Member Information** dialog box will appear.
- ◆ Click the **Properties** tab.

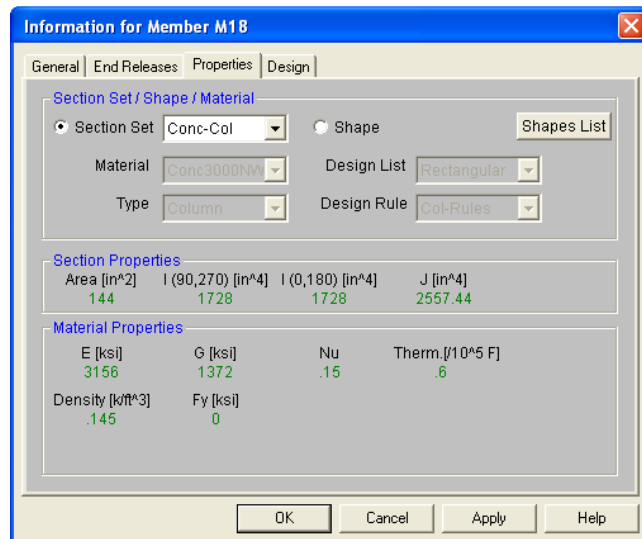

Redefine the section set:

- ◆ Under **Section Set**, click the **Section Set** list to display the available options. Click **Conc-Bm**.
- ◆ Click **OK** to close this dialog box.

Model Rendering

A powerful graphics tool in RISA-2D is the ability to display a rendered image of the model. A rendered image shows each member plotted using a true scale representation of the shape assigned to the member.

A rendered view offers some important benefits: besides producing a very detailed image, it also allows you to easily review member orientations and member connectivity. There are also rendering options (on the **Model Display Options** dialog box, **Members** tab) that allow you to adjust pullback length and rendering transparency.

Turn on the model rendering:

- ◆ On the Window toolbar, click **Rendering** .

Copying Model Elements

RISA-2D allows you to copy selected portions of the model. You will use this feature to turn your two-dimensional model into a two-bay structure.

- ◆ On the Drawing toolbar, click **Linear Offset Copy**  to open the **Copy Selected Items** dialog box. This feature is used to copy the currently selected portion of the model (in increments) in any or all of the global directions.

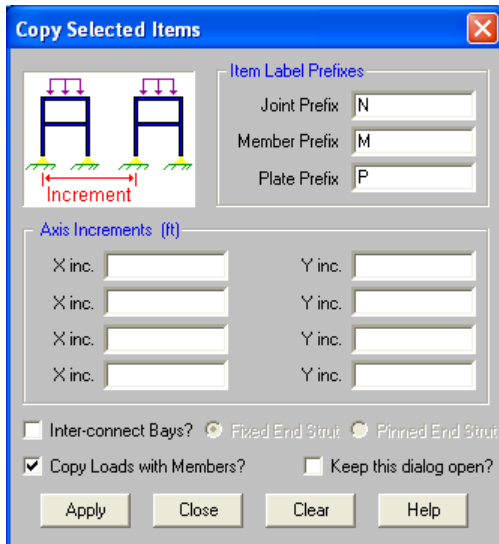

Notice there are four fields used to specify increments in the X and Y directions. When typing values, you can separate entries using commas or use the “@” symbol to specify multiple equal increments.

Replicate your model in the X direction.

- ◆ Under **Axis Increments**, in the first **X inc.** column, type **21**.
- ◆ Click **Apply**.

Because the entire frame was selected, all the frames will be copied. (In addition to copying the joints and members, if you had any loads on the frames they would have also been copied.)

Your structure should now look like this:

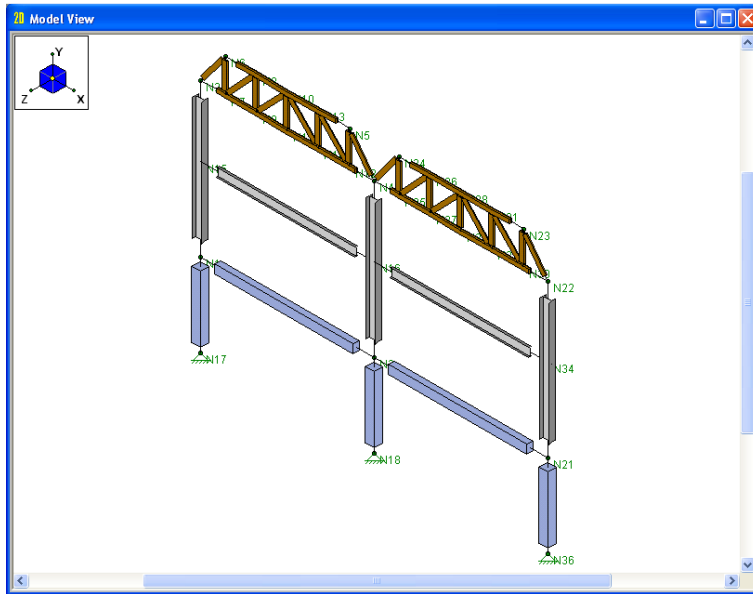

Model Merge

Now that you have copied over your frame, it is good modeling practice to run a Model Merge to “clean up” the model. Model Merge searches for duplicate nodes and members (with the same coordinates) and merges them into one.

Run a Model Merge:

- ◆ On the Drawing toolbar, click **Model Merge** .

The **Model Merge** dialog box will appear:

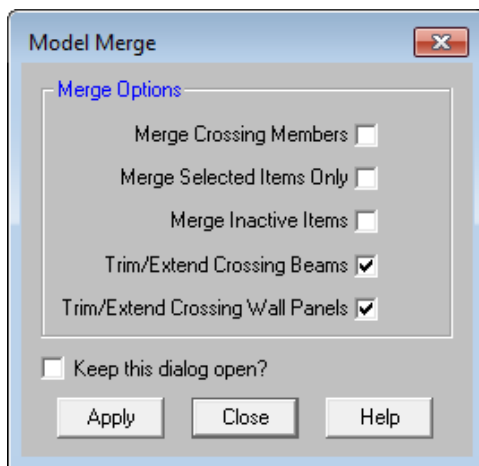

Note: You have the option of merging the entire model or only a selected part of the model depending on which options you select in this dialog box.

- ◆ Click **Apply**. You will be presented with the results of the merge.
- ◆ Click **OK** to close the dialog box.

Drawing Additional Members

Next, you will add steel girts to the columns between the beams. Because there are no joints at these locations, you can either create a drawing grid (as you did in *Tutorial 1*), or you can insert joints on the columns (as you will do next).

- ◆ On the Drawing toolbar, click **Draw New Members** . Click the **Split Members** tab.
- ◆ Click **Specific Location** and type **14** in the box.
- ◆ Under **Physical**, click **Just Add Joints to Physical Members**.
- ◆ Under **What happens when Apply is pressed?**, click **Apply Entries by Clicking Members Individually**.

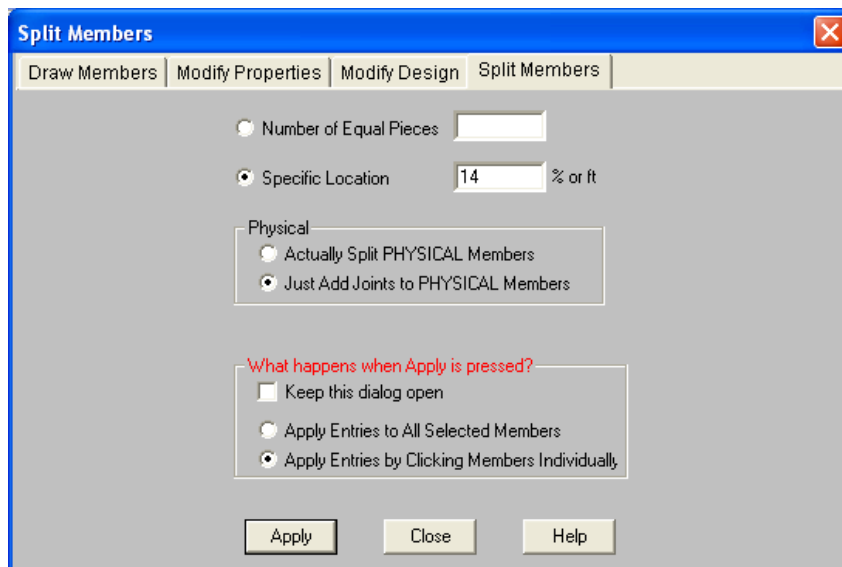

Close the dialog box and begin to draw:

- ◆ Click **Apply**.
- ◆ Click once on each of the three steel columns.

New nodes will appear on the upper half of the columns between the two beams. (You may use the mouse wheel to zoom in to see them closer.)

- ◆ Press **CTRL+D** to re-open the **Draw New Members** dialog box. Click the **Draw Members** tab.
- ◆ Under **Member Material Type and Shape**, click **Cold Formed**. Click **Assign a Section Set**, and select **Girt** from the list.
- ◆ Under **Release Codes**, click **Pinned at Both Ends**.

You also want the cold formed members to be turned so that their strong axis resists wind load. Specify the rotation angle before drawing them:

- ◆ Under **Orientation**, in the **Rotate Section** box, select **90**.



Close the dialog box and prepare to draw again.

- ◆ Click **Apply** and you are ready to draw.

Tutorial 2 – Modifying

Draw from left to right:

- ◆ Click **N33** (coordinates: **0,14**), **N34A** (coordinates **21,14**), and **N35** (coordinates **42,14**) shown in the figure below.

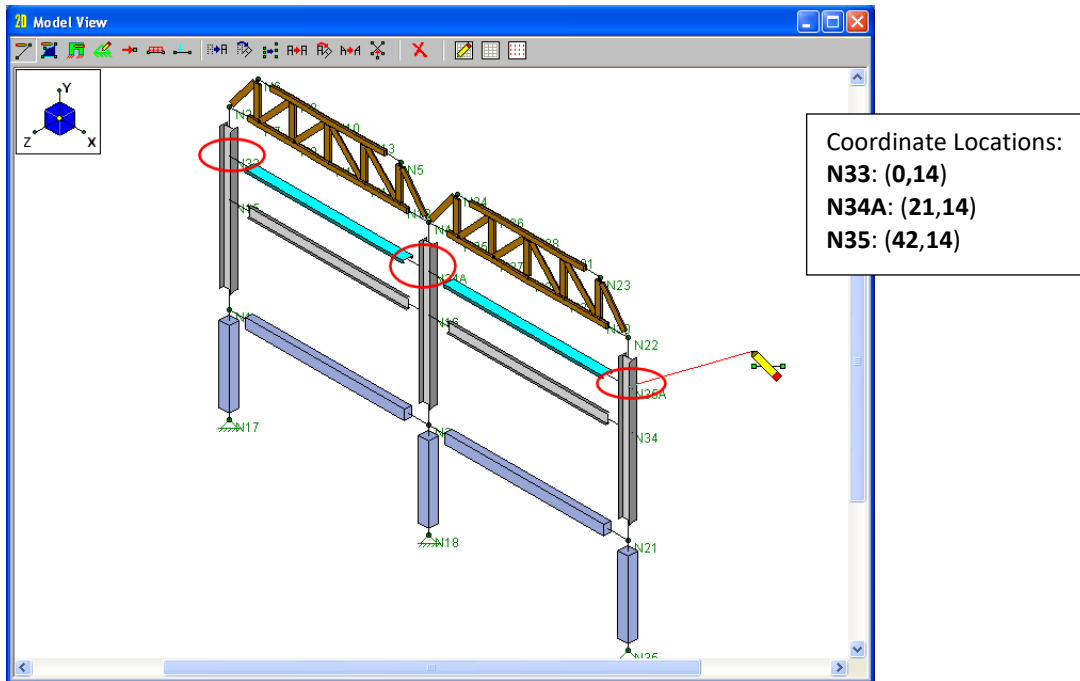

- ◆ When finished, right-click to release the mouse.

Next, you will draw in the final Aluminum members. To make this easier, you will modify the drawing grid. These settings allow you to set up a grid of graphical editing points along any orthogonal plane. They also allow you to automatically snap to the quarter or third points of existing members.

- ◆ On the Drawing toolbar, click **Modify Drawing Grid** . Click the **Snap To Options** tab.
- ◆ Under **Member Snap Locations**, click to clear the **Third Points** check box. The **Quarter Points** check box should already be selected.
- ◆ Under **Universal Snap Increments**, make sure the **Use Universal Increments** check box is not selected.

The dialog box should now look like this:

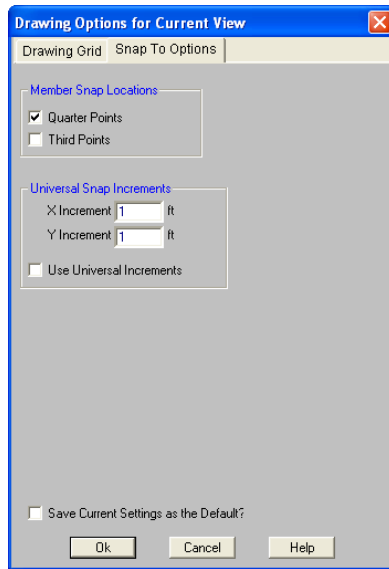

Close the dialog box and begin drawing:

- ◆ Click **Ok**.

Draw the aluminum tubes using the drawing points defined at the quarter points of the columns.

- ◆ Select **Members** from the **Insert** menu to open the **Draw Members** dialog.
- ◆ Under **Member Material Type and Shape**, click **Aluminum**. Click **Assign a Section Set**, and select **Alum-Bms** from the list.
- ◆ Under **Release Codes**, click **Pinned at Both Ends**. Change the **Orientation** back to **0** degrees.

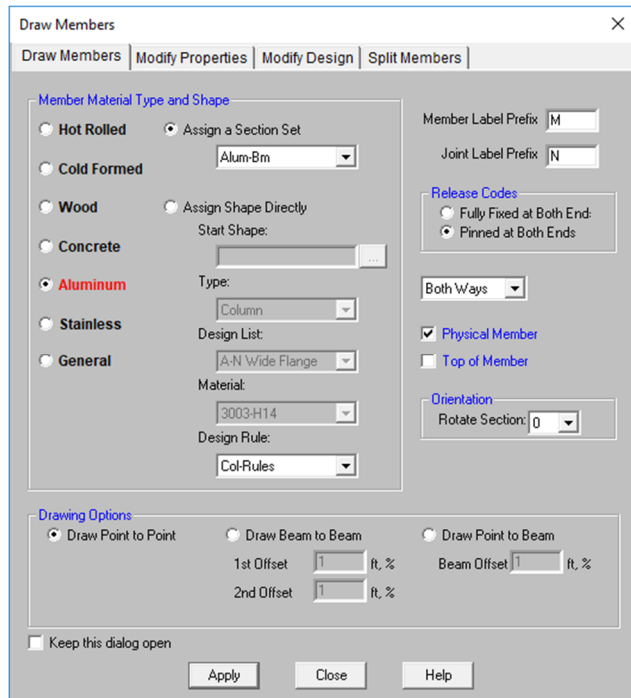

- ◆ Click **Apply** to start drawing.

Tutorial 2 - Modifying

- ◆ Click the left column coordinate (**0,4.625**). Then click the middle column coordinate (**21,4.625**) and the right column coordinate (**42,4.625**).

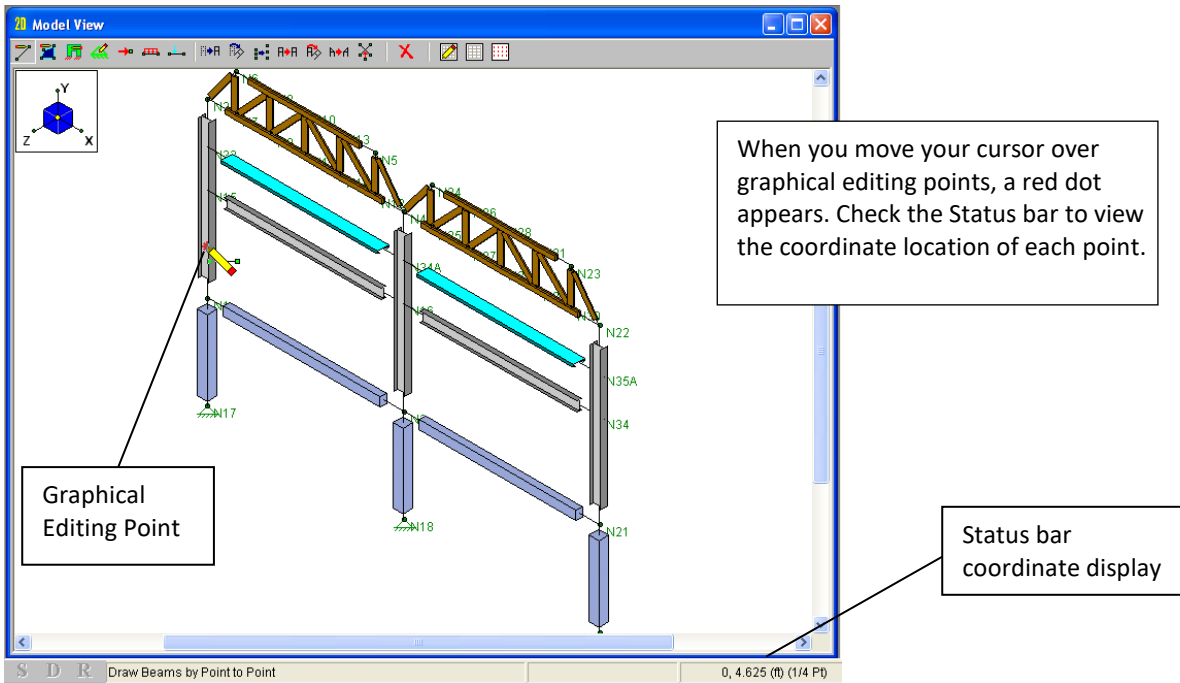



- ◆ When you are finished drawing, right click to release the mouse. Right click a second time to exit the drawing mode.

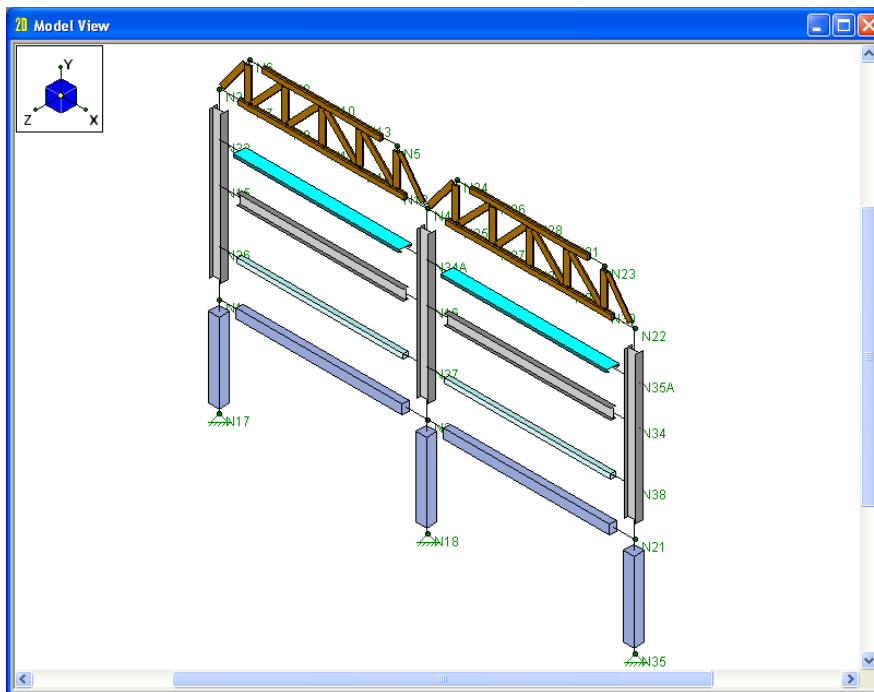

When you are finished your screen should look like this:



Next, you will modify your model by rotating the three steel columns 90 degrees.

Selecting By Properties

One way to select these members quickly would be to snap to an elevation view and use the **Line Select**  tool to draw a line through all columns at one time. Another method, which you will use below, is to use the **Criteria Selection** button  to select all members with the column properties.

- ◆ On the Window toolbar, click **Redraw**  to view the entire model.
- ◆ On the Selection toolbar, click **UnSelect All** .

Now that the entire model is unselected, use the **Selection Criteria** tool to select just the three steel columns.

- ◆ On the Selection toolbar, click **Criteria Selection** . Click the **Members** tab.
- ◆ Under **Parallel**, in the **Parallel to Axis** list, click **Y**.
- ◆ Under **Member Properties**, in the **Material** list, click **A992**.

Your dialog window should look like this:

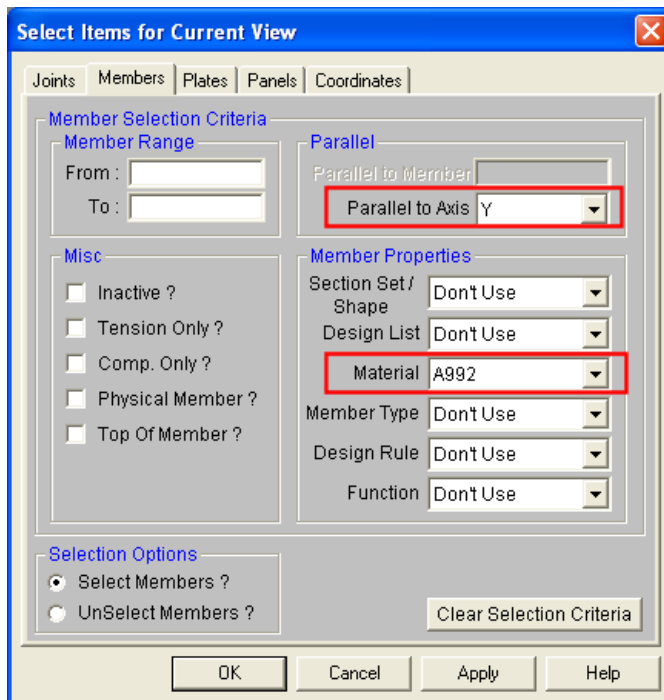

Use this dialog box to select joints, members and plates by the properties that define them.

Once you click **OK**, all the steel columns should now be selected:

- ◆ Click **OK**.

Tutorial 2 - Modifying

Your model should look like this:

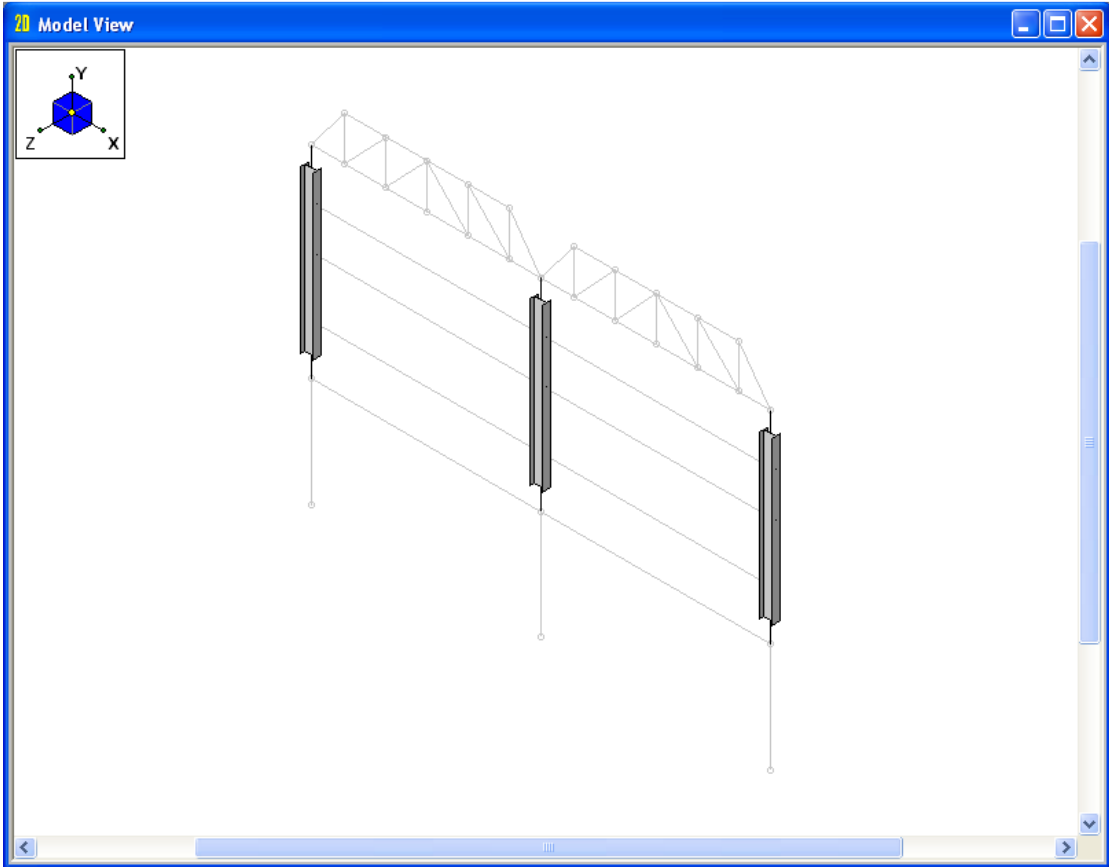

Modify Members

You will now rotate your columns.

- ◆ Select **Members** from the **Modify** menu.

Begin by clearing the previous selections.

- ◆ Click the **Clear Use** button at the bottom.

Now, set the orientation angle:

- ◆ In the **Orientation** section, select the **Use?** check box.
- ◆ Under **Orientation**, in the **Rotate Section** list, click **90**.
- ◆ Under **What Happens when Apply is pressed?** click **Apply Entries to All Selected Members**.

The dialog box should now look like this:

The screenshot shows the 'Modify Properties for the Selected Members' dialog box with the following settings:

- Member Material Type and Shape:** Wood (selected), Assign a Section Set (selected), Web (selected), Type: Beam, Design List: None (No Redesign), Material: DF.
- Start Release Codes:** Fully Fixed (No Releases) (selected), Pinned, Set Individual Release Codes: Axial, Shear, Moment.
- End Release Codes:** Fully Fixed (No Releases) (selected), Pinned, Set Individual Release Codes: Axial, Shear, Moment.
- Orientation:** Rotate Section: 90, Use? (checked).
- Rigid End Offsets:** I End, J End (both empty), Use? (unchecked).
- Deflection Ratio:** Default (selected), Custom, I End: Supported, J End: Supported.
- Misc:** Both Ways (selected), Use? (unchecked), Physical (checked), Use? (unchecked), TOM (unchecked), Use? (unchecked).
- Member Activation:** Member is Active (selected), Member is Active, but Excluded from Results, Member is NOT Active.
- What happens when Apply is pressed?:** Keep this dialog open (unchecked), Apply Entries to All Selected Members (selected), Apply Entries by Clicking Members Individually (unchecked).

Buttons at the bottom: Apply, Clear Use, Close, Help.

Apply the changes and close the dialog box:

- ◆ Click **Apply**.

Tutorial 2 - Modifying

Notice now that these three columns have rotated 90 degrees about their vertical axes:

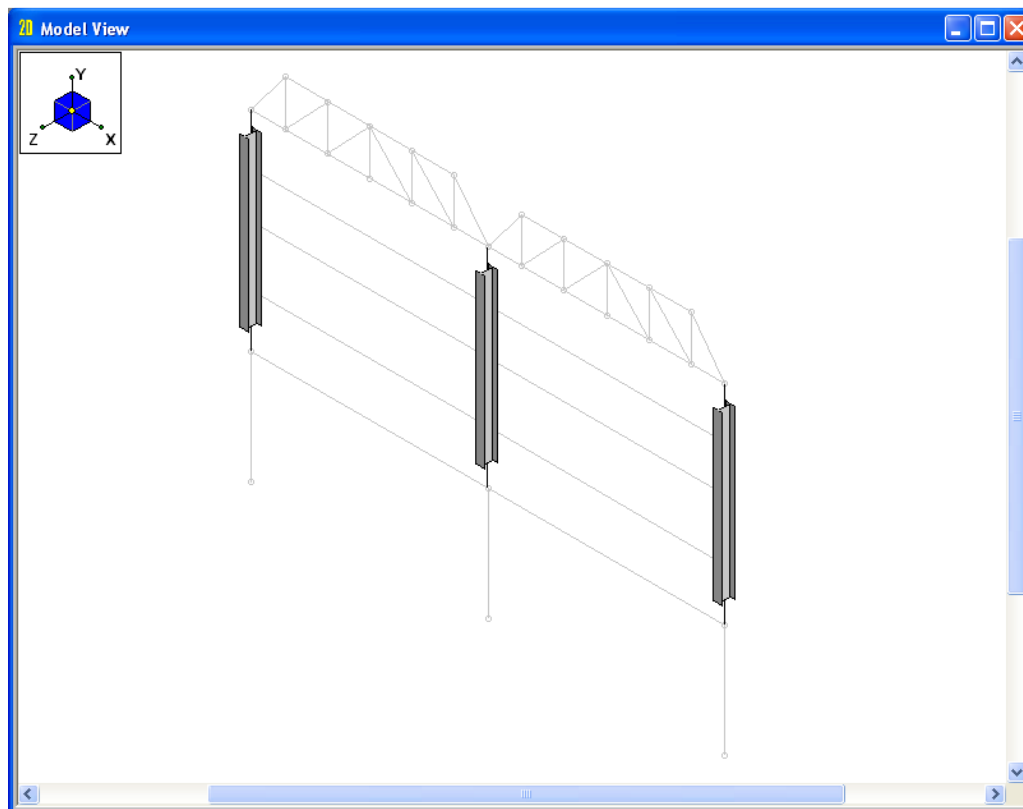

Reselect the entire model:

- ◆ On the Selection toolbar, click **Select All**  to select the entire model.

Scaling Elements

Assume your client has just submitted a change order to raise the truss from 18'-6" to 22'-9", and would like the frame 25% wider (from 21' to 26'3"). The client would like the completed design this afternoon!

These are significant changes to the model. If you were using a batch input program or a program heavily reliant on "parametric" data generators, you would probably be required to start the data entry process completely from scratch to create the new model.

A major strength of RISA-2D is the ability to make these types of changes to existing data. RISA-2D allows you to make all the requested changes graphically (using the built-in graphical editing tools), or numerically (using the spreadsheets), or a combination of both—whichever you prefer. Either way, the modifications will be quick and easy to model.

For this tutorial, you will make the changes graphically. To begin, widen the truss using the **Scale** feature:

- ◆ Click the **Modify** menu and select **Scale**.

Note: This tool is also available on the Drawing toolbar, as the **Scale Factor Move** button .

To widen the truss, scale the model in the global X direction.

- ◆ Under **Scale Factor**, in the **X Factor** box, type **1.25**.

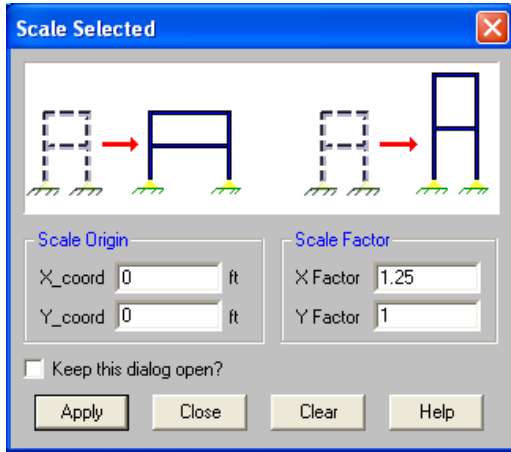



The **Scale Origin** is the point that will remain stationary as the selected items are scaled.

Scale Factor defines the scale factors in each global direction.

- ◆ Click **Apply**.

You are now finished widening the truss. Next, you will raise the truss. You cannot use the Scale feature to raise the truss because it would also lift the crossbeams. So instead, use the Move feature. Because you want to move the truss and nothing else, you must first make a selection of the truss.

It will be easier to work with an elevation, so change the elevation, then select your truss:

- ◆ On the Window toolbar, click **XY Planar** .
- ◆ On the Selection toolbar, click **Unselect All** . Then, click **Box Select** . Draw a box around the entire truss. Right-click to release the selection tool.

Your selection of the truss should look like this:

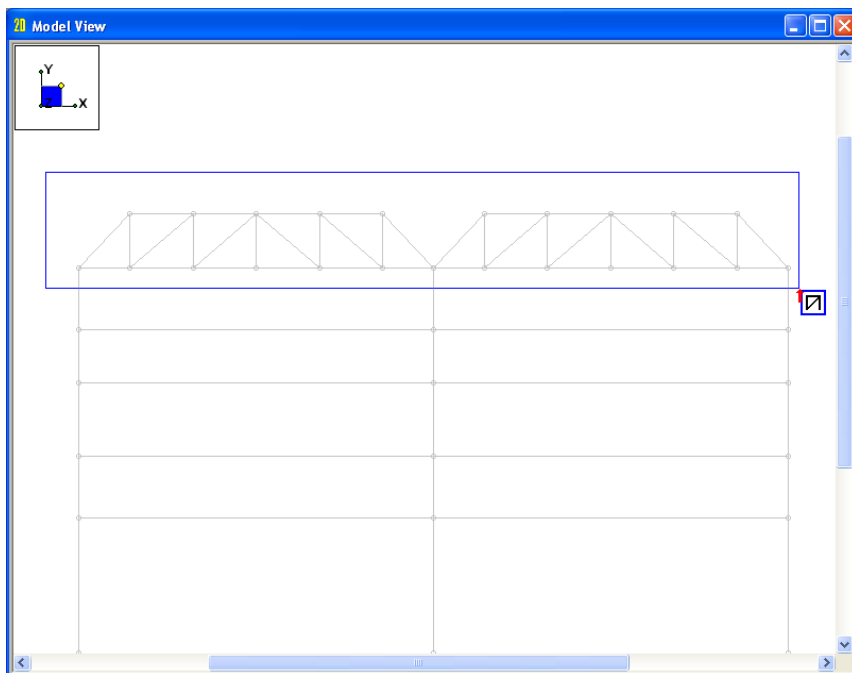

Tutorial 2 – Modifying

Change the elevation as follows:

- ◆ On the Drawing toolbar, click **Linear Translation Move** .
- ◆ Under **Move Distance (ft)**, double-click in the **Y** box and type **4.25**.

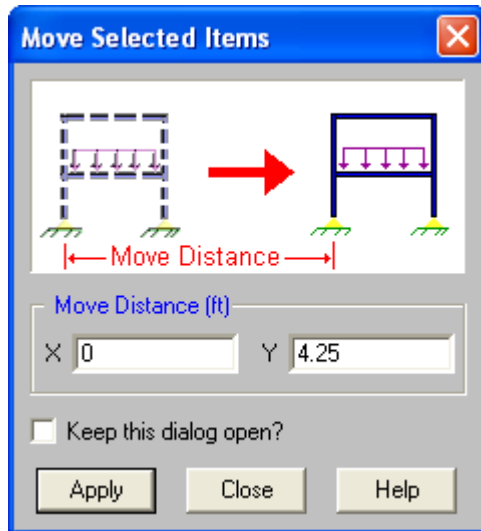



- ◆ Click **Apply**.

Note: You could have also used the **Block Math** feature in the spreadsheets to accomplish both modifications numerically. To widen the structure, you would have simply multiplied the joint X coordinates by 1.25. To raise the truss, you would have first sorted the Y coordinates and then selected the coordinates that are at an elevation of 8.5 ft or higher. The final step would have been to use the **Block Math** feature to add 4.25 to these selected Y coordinates.

Wall Panels

The final model modification will be the addition of a wall panel under one bay of the model. In order to draw this in, you must first delete the concrete members and boundary conditions on the right side of the structure.

Use the **Selection Criteria** tool to select the members you will need to delete:

- ◆ On the Selection toolbar, click **Unselect All** .
- ◆ On the Selection toolbar, click **Criteria Selection** . Click the **Members** tab.
- ◆ Click on the **Clear Selection Criteria** button to clear the previous selection.
- ◆ Click on the **Material** menu and select **Conc3000NW**.

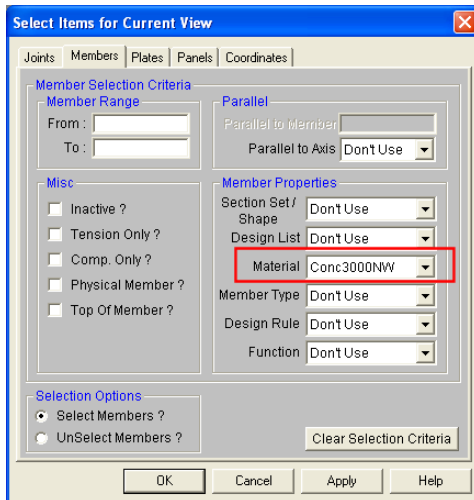

- ◆ Click on the **Coordinates** tab.
- ◆ Click in the **Minimum** cell for the **X Coordinate**. Type in **26.25**.
- ◆ Click in the **Maximum** cell for the **Y Coordinate**. Type in **0**.

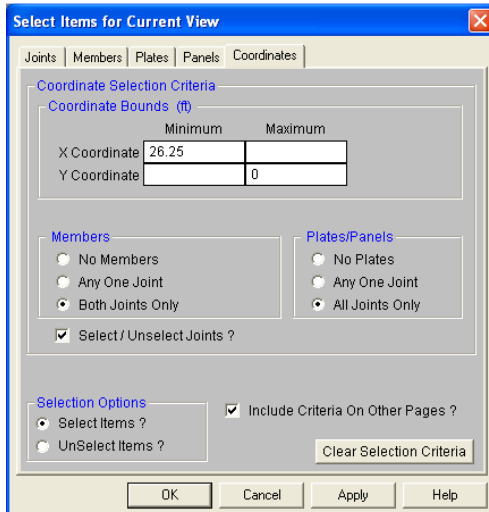

- ◆ Make sure the **Include Criteria On Other Pages** checkbox is selected and click **OK**.

Tutorial 2 - Modifying

Your model should now look like this:

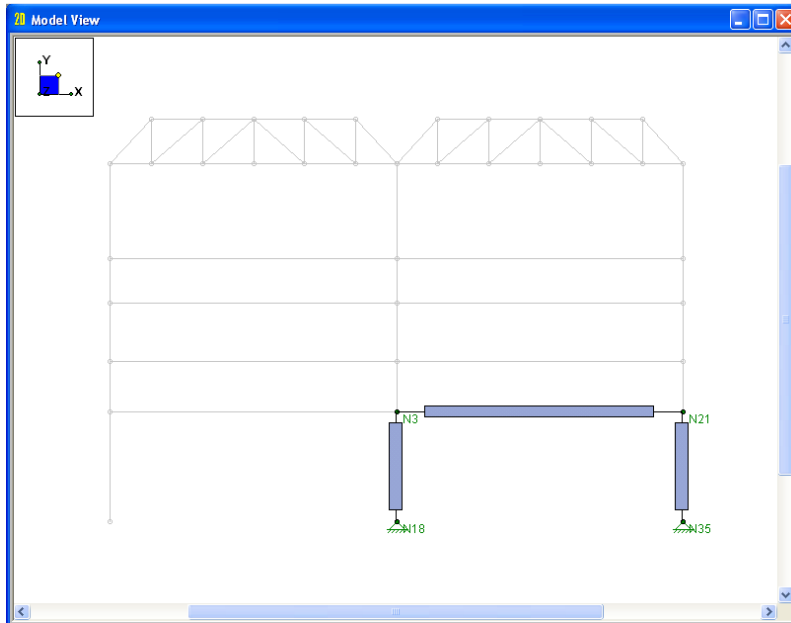

Now to delete the concrete members:

- ◆ From the Drawing toolbar, select **Delete** .
- ◆ Select **Delete Based on This Criteria** and select **Delete Selected Members**, as shown below:

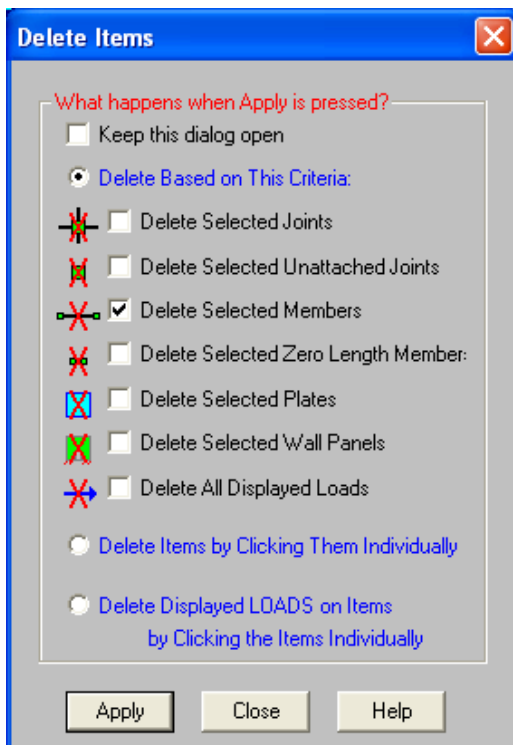

- ◆ Click **Apply**.

Finally, you will need to delete the boundary conditions but not the nodes at the base. To do this, simply delete the lines from the appropriate spreadsheet:

- ◆ From the **Spreadsheets** menu, select **Boundary Conditions**. This will open the **Boundary Conditions** spreadsheet.
- ◆ Click in the **Joint Label** cell of row **2** to highlight that cell in green, making it the active cell.

	Joint Label	X [k/in]	Y [k/in]	Rotation[k-ft/rad]
1	N17	Reaction	Reaction	
2	N18	Reaction	Reaction	
3	N35	Reaction	Reaction	

- ◆ Press the F4 button twice to delete rows **2** and **3**.

When completed, the spreadsheet should look like this:

	Joint Label	X [k/in]	Y [k/in]	Rotation[k-ft/rad]
1	N17	Reaction	Reaction	

- ◆ Close the spreadsheet.

Now, you can draw in your wall panel.

- ◆ On the Drawing toolbar, click **Draw New Wall Panels** .
- ◆ Under the **Material** section, select **Masonry**.

Draw Wall Panels

Draw Wall Panels | Modify Wall Panels

Material Type

- Masonry**
- Wood
- Concrete
- General

Material Set: Concrete Mat

Design Rule: Typical

Panel Thickness (in): 10

Panel Label Prefix: WP

Joint Label Prefix: N

Create Wall Panels by Clicking On Grid Areas?

Keep this dialog open

Apply Close Help

- ◆ Click **Apply** to draw in the wall panel using the default values.

Tutorial 2 - Modifying

Note: Your cursor will now change to , indicating you are ready to draw your wall panel.

Begin drawing the wall panel:

- ◆ Click each node to define the four corners of the structure: start with **N18** (coordinates **26.25, -10**), then move clockwise to **N3** (coordinates **26.25, 0**), **N21** (coordinates **52.5, 0**), and finally **N36** (coordinates **52.5, -10**).
- ◆ When finished drawing the wall panel, press the right mouse button or ESC to exit the drawing mode.

Your screen should now look like this:

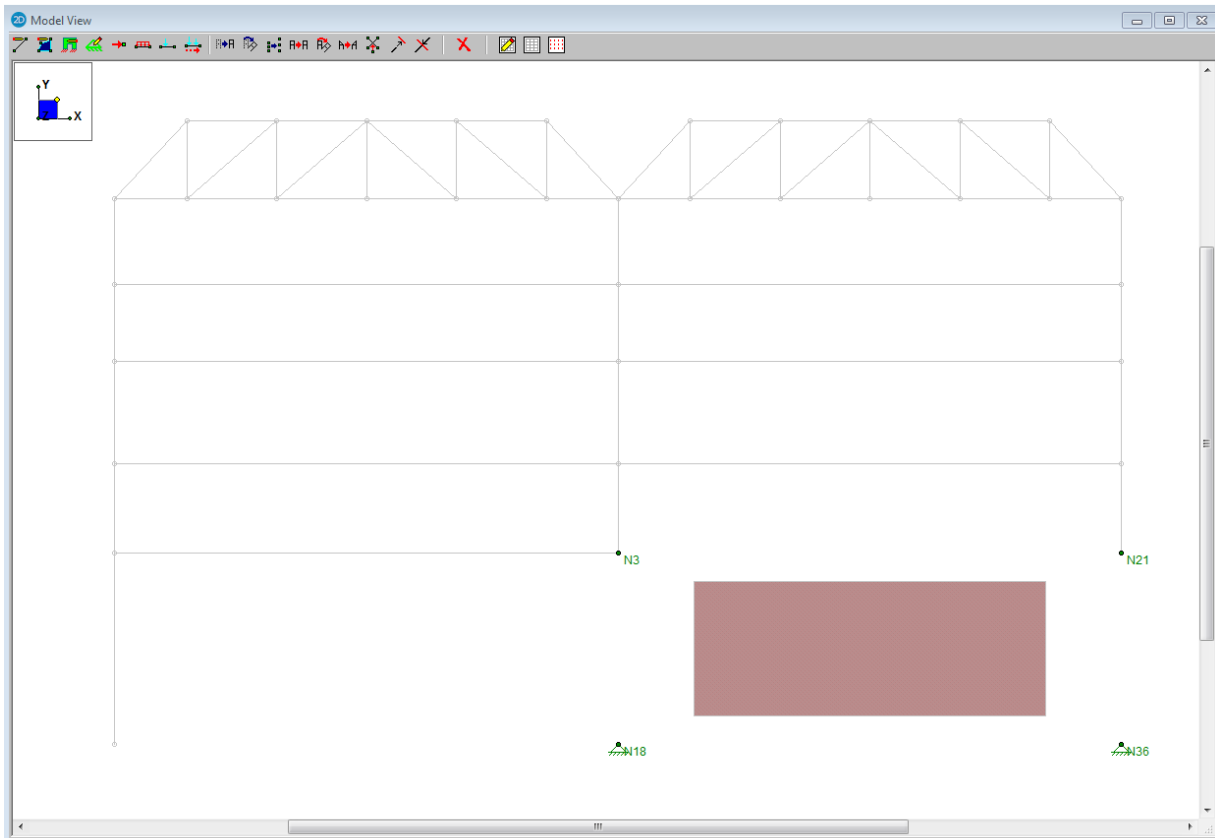

Notice the default rendered wall panel does not fully extend to its corner nodes. This is because the default view for wall panels has a rendered size of 80%. Change this to a size of 100% for a better view:

- ◆ On the Window toolbar, click **Model Display Options** . Select the **Panels** tab.
- ◆ Under **Draw Wall Panels As**, click **Rendered**. In the **Size** list, click **100%**.
- ◆ Click **OK** to exit the dialog box and return to your model.

Your wall should now be rendered at 100%.

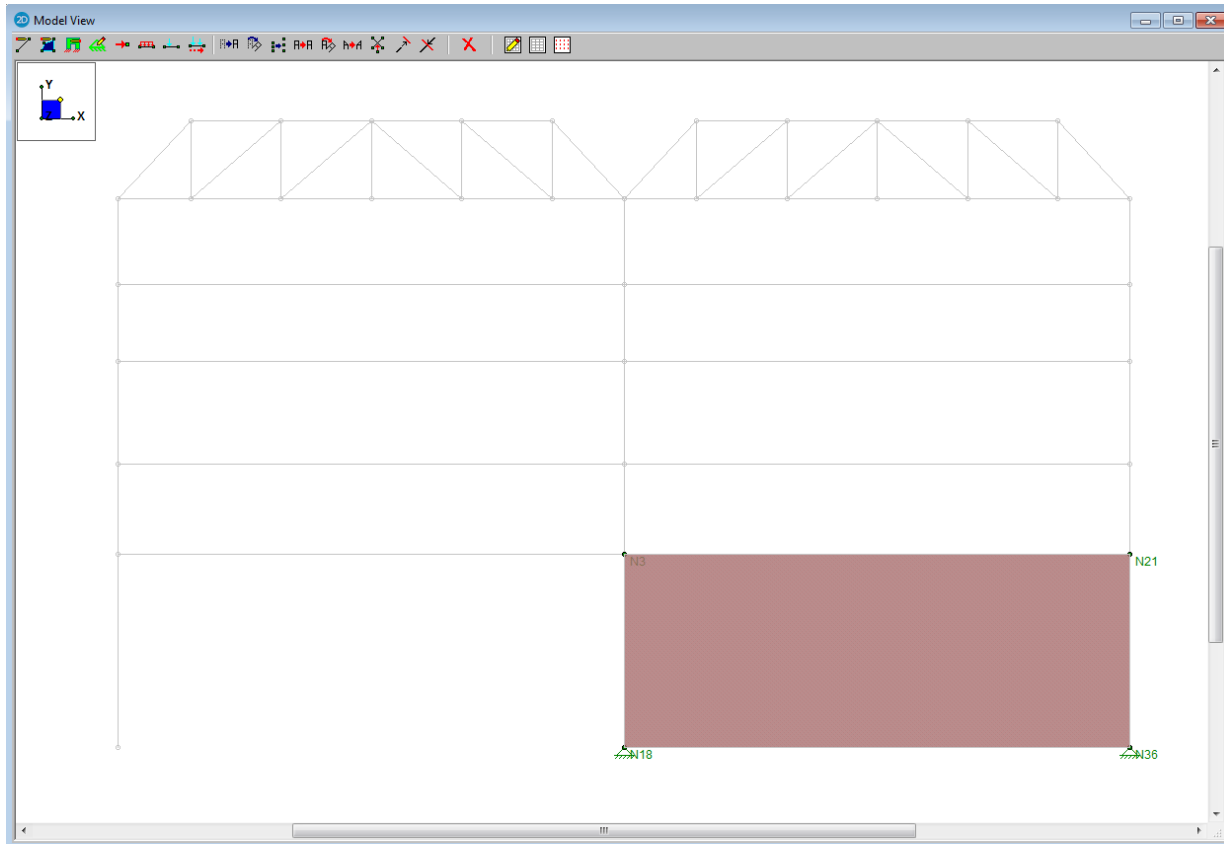

This was just a simple overview of the masonry wall panel feature. For more detailed information on this feature and how to use it to set up design rules, regions, and openings for both masonry and wood walls, refer to the Wall Panel Tutorials available on our website:

http://www.risa.com/d_documentation.html.

Design Parameters

Before solving the model, design code parameters, such as unbraced lengths, must be specified. Once again, you will assign these values graphically. To view the parameters for any one member you can also double-click that member. The values will be recorded on the **Member Design Parameters** spreadsheet.

- ◆ First, select your entire model by clicking on the **Select All**  button from the Selection toolbar.
- ◆ On the **Modify** menu, select **Design Parameters**. Click the **Modify Design** tab (if it is not already selected).
- ◆ In the **Lb/le/Lu (out)** box, type **Segment** (or **Seg**). Also, select the **Use?** check box. (It will display in red once it is selected.)
- ◆ Under **What happens when Apply is pressed?**, click **Apply Entries to All Selected Members** as shown below:

The dialog box should look like this:

These parameters are used to specify unbraced lengths. If left blank, RISA-2D will calculate the full length of the member.

For weak axis bending, as a result of using the **Segment** code, each node will be treated as a brace point.

Parameters with three labels separated by a slash (/) indicate steel/ timber/concrete.

Currently, all the options are left blank except the first:

- ◆ Click **Apply**.

To visually see the settings for the unbraced lengths, you can double-click any member, click the **Design** tab, then review the unbraced lengths (this information is also accessible from the **Members** spreadsheet).

Each parameter is described below. Refer to the **Help** or *RISA-2D General Reference* for more information.

Flexural Properties	
Lb-comp/le-bend	The Lcomp values (used for steel) are the laterally unbraced length of the compression flanges used in the calculation of member strength. The le-bend values (used for wood) are used in the calculation of R_b .
CH/w1 and Cm/w1	CH is the NDS shear stress factor. The Cm factor, used in the calculation of the bending stress ratio for steel allowable stress design, may be entered if you wish to use a specific value. If left blank, it will be calculated by RISA-2D.
Cb/w2/B	Lateral-torsional buckling modification factors. If you leave the Cb factor blank during allowable stress design, RISA-2D will calculate it for you.
R (AISI)	Per <i>section C3.1.3 of the AISI</i> . Used to calculate the moment capacity of cold formed beams that have one flange fastened to decking.
C1 (Euro HR)	Factor used in the calculation of the LTB capacity per the Eurocode.
Concrete Properties	
Icr Factor (ACI)	Cracked moment of inertia factor for concrete design.
Effective Width	These are the effective width values used in T-Beam and L-Beam concrete sections.
Slab Thickness	These are the slab thicknesses used in T-Beam and L-Beam concrete sections.
Layouts	Reinforcement layouts for concrete member design. These can be set to default for program design, or set to a custom rebar layout.
Axial/Torsional Properties	
Lb/le/Lu	Unbraced lengths for in plane and out of plane buckling of the member (where Lb is steel and le is wood). These are used in KL/r ratio calculations for steel & concrete, and le/d calculations for wood.
K factors	Effective length factors for column type buckling. A value of 1.0 will be used if left blank.
General/Misc Properties	
Function	Function for stiffness reduction per the <i>AISC 360-10 (14th Edition) Steel Code</i> Direct Analysis Method design.
Design Rules	Design rule for design optimization.
CV (NDS)	This is the volume factor for glued laminated or SCL wood design per the NDS.
Sway check boxes	These check boxes indicate whether the member is to be considered subject to sidesway or not for in plane or out of plane bending (applies only to the calculation of K factors, Cm and Cb factors).
Cr (NDS)	This is the repetitive member factor used in NDS wood design.

Sorting

Next, you will sort information in your model using the **Joint Coordinates** spreadsheet for the first time. To be able to view the spreadsheet and the model view side by side, use the **Tiling** feature:

- ◆ On the RISA toolbar, click the **Tiling** button.
- ◆ Select **Joints Input**.
- ◆ Click **OK**.

This tiling option has opened the **Joint Coordinates** spreadsheet in the upper left corner and placed the **Joint Boundary Conditions** spreadsheet below it:

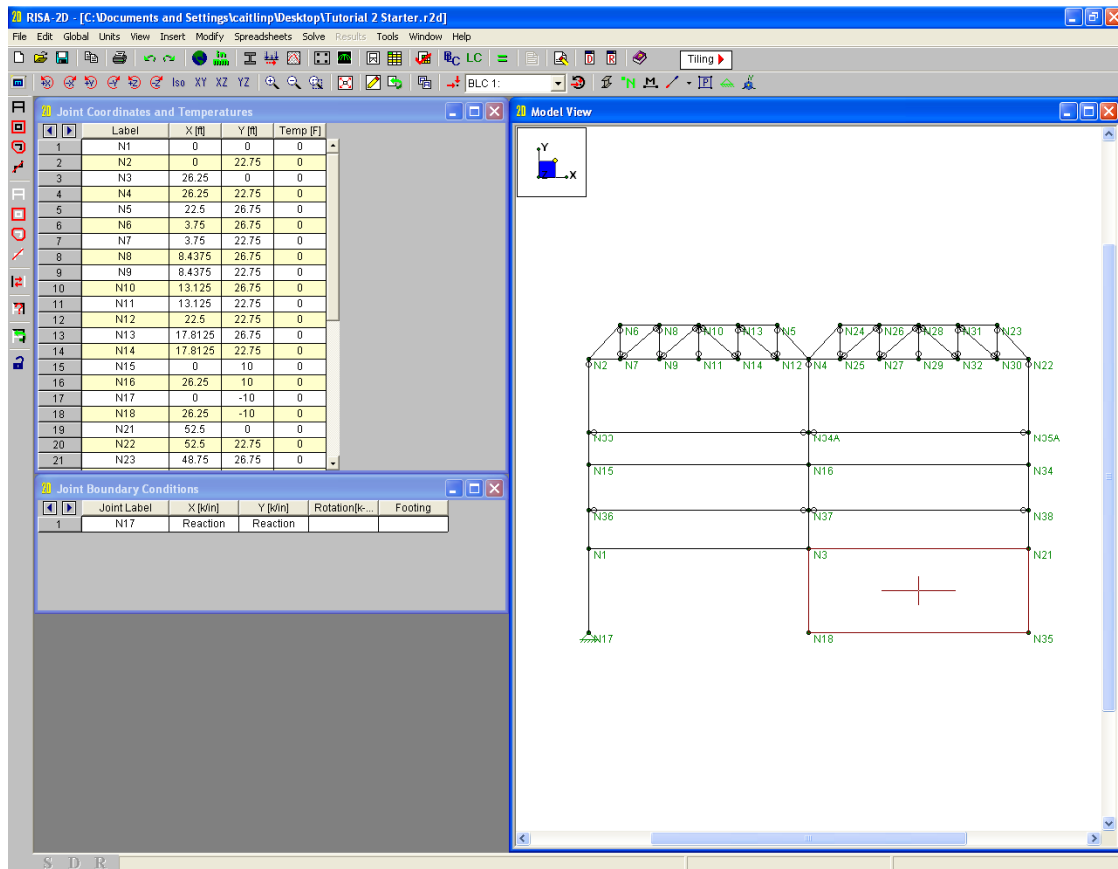

The joints are listed in the order in which they were created as you defined your model. However, it would be more useful to list them based on their coordinate locations. Sort the joints in ascending X coordinate order:

- ◆ On the **Joint Coordinates** spreadsheet, click anywhere in the **X** column.
- ◆ On the Window toolbar, click **Sort** , select **Sort Low to High**, and click **OK**.

The joints are now sorted in ascending X coordinate order. Now, add a Y-coordinate sort:

- ◆ Click anywhere in the **Y** column.
- ◆ Right-click the mouse, select **Sort** , click **Sort Low to High**, and click **OK**.

Now you have the joints in ascending Y coordinate order as well as in ascending X coordinate order. Notice that the labels stayed with their assigned joints, and the model plot looks exactly the same.

Relabel the joints as follows:

- ◆ On the **Tools** menu, select **ReLabel Joints**.
- ◆ Type an “**N**” in the **Prefix to be used for the new joint labels** box. Click **OK**.

The model should now look like this:

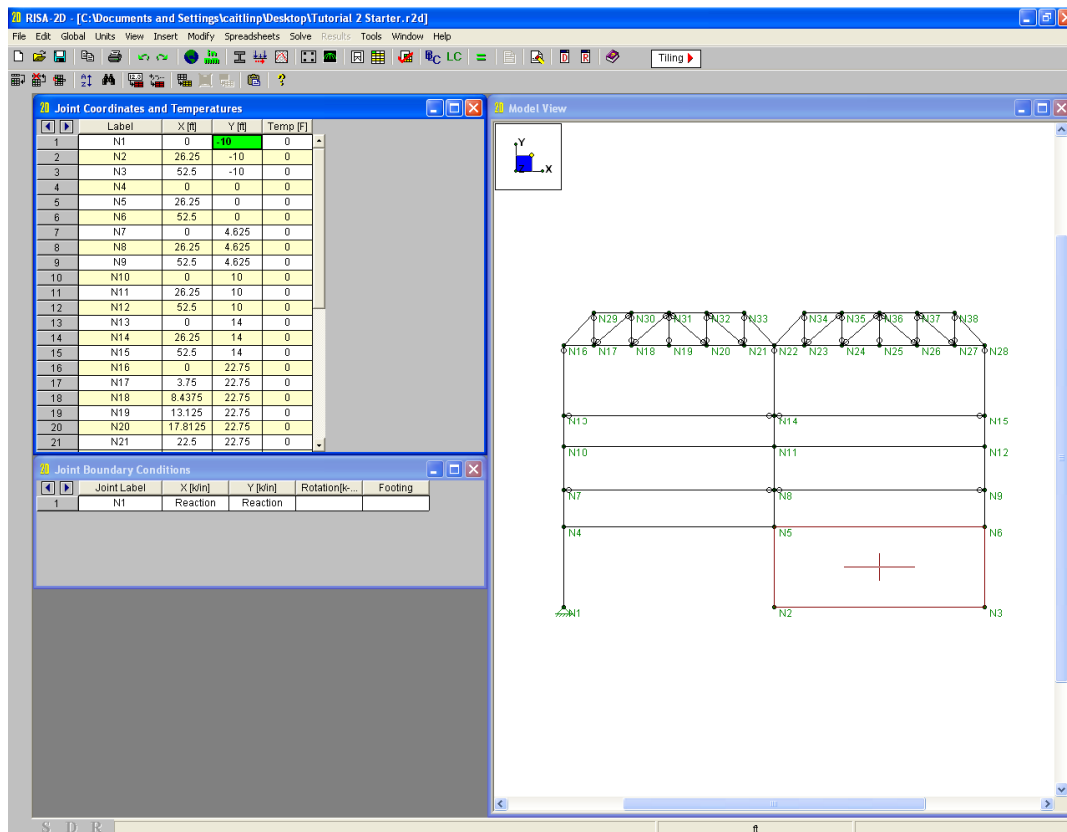

Tutorial 2 – Modifying

Notice the joints have been relabeled from the bottom up. Next, sort the members.

- ◆ On the RISA toolbar, click **Tiling** again.
- ◆ Select **Members Input**.
- ◆ Click **OK**.

This displays all spreadsheets that contribute to the definition of members. The **Members** spreadsheet is located in the lower left corner. Use this to sort the members, first by their I-Joint:

- ◆ On the **Member Primary Data** spreadsheet, click anywhere in the **I-Joint** column.
- ◆ Right-click the mouse, select **Sort** , click **Sort Low to High**, and click **OK**.

Then sort by the section set:

- ◆ Click anywhere in the **Section/Shape** column.
- ◆ Right-click the mouse, select **Sort** , click **Sort Low to High**, and click **OK**.

Again, the member labels remain with the same members and the view has not been affected by the sort (because nothing has actually changed other than how the members are arranged in the spreadsheet).

Next, sort your beams by section. This will make them easier to identify and work with in your next operation (assigning parameters for steel and wood design):

- ◆ On the **Tools** menu, select **Relabel Members**.
- ◆ Type an “**M**” in the **Prefix to be used for the new member labels** box. Click **OK**.

This is the end of Tutorial 2. The next tutorial demonstrates how to load the model.

You may save your model to be used as the starting point for the next tutorial, or begin the next tutorial using the .r2d starter file in the RISA-2D **Tutorials** folder. To save the model:



- ◆ On the **File** menu, click **Save As** and enter a file name.

Tutorial 3 – Loading





Overview

In this tutorial, you will apply loads and explore how to generate load combinations from pre-defined load cases. This tutorial continues where the previous tutorial ended, so follow these steps to get your model up and running:

If you are continuing from the previous tutorial:

- ◆ From the **Window** menu, select **Single View**.
- ◆ On the Window toolbar, click the **Graphic Editing Toolbar** button  to activate the Drawing toolbar.
- ◆ On the **Data Entry** toolbar, click **Close**  to close it.
- ◆ Skip ahead to the next page.

-OR- If you are starting here from scratch, follow the steps below to load the starter file provided by RISA Technologies:

- ◆ Double-click the **RISA-2D** icon to start the program. The **Starting a Model** dialog box will display.
- ◆ Click **Open File** . Double-click the **Tutorials** folder, select **RISA-2D Tutorial 3 Starter.r2d** and click **Open**.
- ◆ Click **Close**  (or **Cancel**) to exit the **(Global) Model Settings** dialog box.
- ◆ On the Window toolbar, click the **Graphic Editing Toolbar** button  to activate the Drawing toolbar.
- ◆ On the **Data Entry** toolbar, click **Close**  to close it.

Your model should look like this:

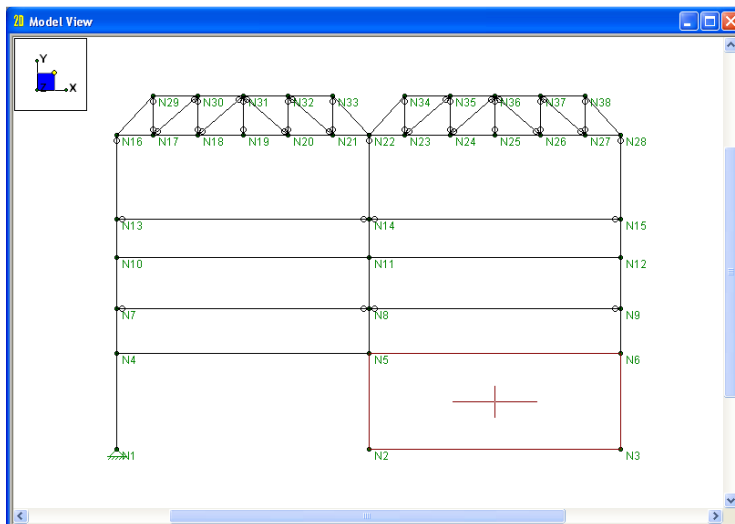

Load Cases, Categories, and Combinations

Before you load the model, it is important to understand how RISA-2D manages loads. When loads are defined in RISA-2D, they are assigned to a Basic Load Case, which is simply a set of loads. You can have up to 1000 separate basic load cases (BLCs) defined in the **Basic Load Cases** spreadsheet. RISA-2D also provides an option to assign the BLCs to Categories (DL, LL, etc.), which allows you to easily combine them later in the Load Combinations. When you are ready to solve the model, the BLCs (or BLC categories) are combined with multipliers to create load combinations in the **Load Combinations** spreadsheet.

In order to keep your loads organized, first define your Basic Load Cases. Then, when you apply your loads, specify which load case each will be assigned to. Although a description is not required by RISA-2D, below you will give a description for the BLCs you will be using.

- ◆ On the **Spreadsheets** menu, click **Basic Load Cases** to open the **Basic Load Cases** spreadsheet.
- ◆ Under **BLC Description**, in row **1**, type **Roof Load**. Press ENTER.
- ◆ In row **2**, type **Wind Load**. Press ENTER.
- ◆ In row **3**, type **Dead Load**. Press ENTER.

Your spreadsheet should now look like this:

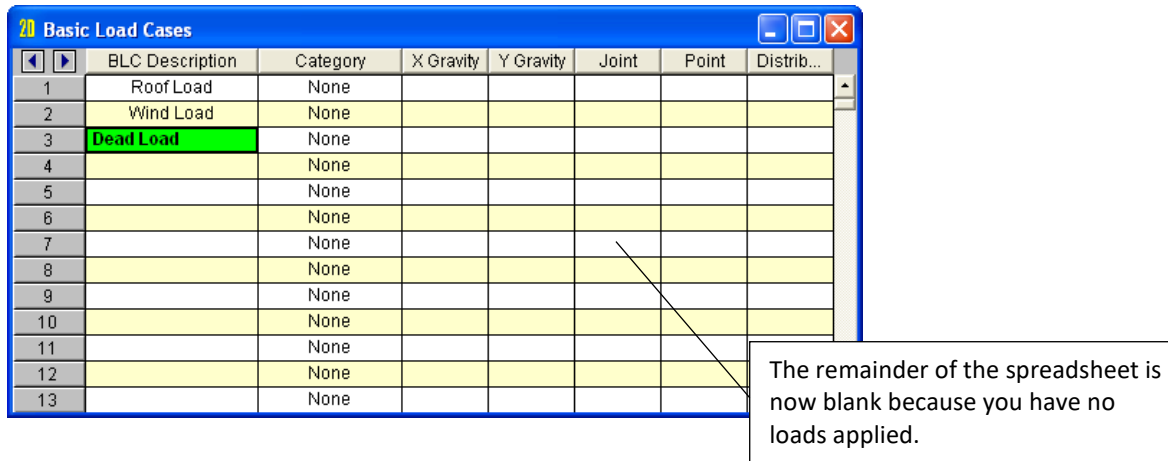

	BLC Description	Category	X Gravity	Y Gravity	Joint	Point	Distrib...
1	Roof Load	None					
2	Wind Load	None					
3	Dead Load	None					
4		None					
5		None					
6		None					
7		None					
8		None					
9		None					
10		None					
11		None					
12		None					
13		None					

Next, you will apply the loads and then come back to this spreadsheet to discuss it further.

- ◆ Click **Close**  to exit the spreadsheet.

Load Direction Options

RISA-2D allows you to specify the direction of your loads in different ways. The three basic choices are:

- Apply loads aligned with global axes, designated with upper case labels such as **X** and **Y**.
- Apply loads aligned with member or plate local axes, designated with lower case labels such as **x** and **y**.
- Apply projected loads along global axes, designated with upper case labels such as **V** and **H**.

There is no need to worry about remembering the options, as you will be presented with this list each time you define the loads in RISA-2D. Also, the Help menu will provide explanations as needed.

Joint Loads

First, apply Joint Loads to the top of the truss. These will represent your roof load and will be grouped in Basic Load Case 1.

- ◆ On the **Insert** menu, select **Joint Load**.

The **Joint Load** dialog box will display. Here you can specify that you want to apply a joint load, an enforced displacement, or a mass on the joint. Leave it set to joint load.

The direction that you want is the vertical direction. The global axes are plotted in the model view and the vertical is Y. Remember that positive is up. Modify the dialog box as follows:

- ◆ In the **Basic Load Case** list, click **1: Roof Load**.
- ◆ In the **Direction** list, click **Y**.
- ◆ In the **Magnitude** box, type **-4**.

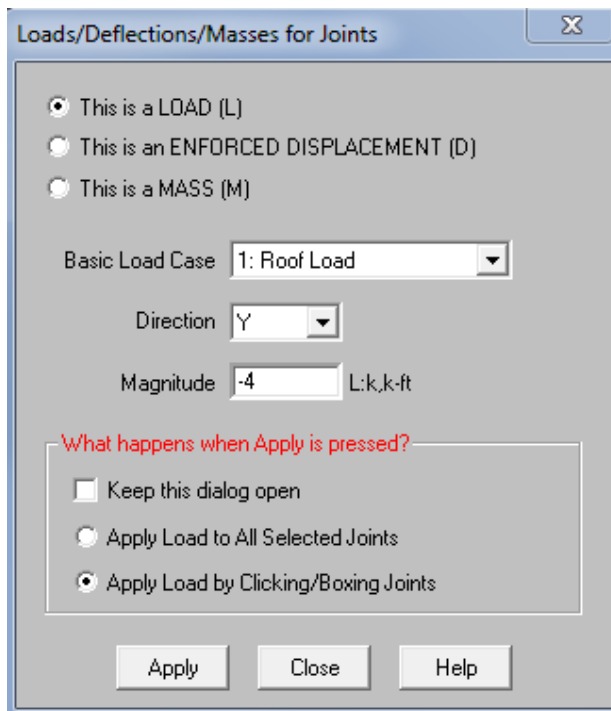

Finally, specify how the loads are applied. As you did with the boundary conditions, apply the load by clicking the joints:

- ◆ Under **What happens when Apply is pressed?**, click **Apply Load by Clicking/Boxing Joints**.
- ◆ Click **Apply**.

Tutorial 3 – Loading

The cursor changes to  indicating that you can click or box the joints. Apply loads to the interior joints on the top of the trusses and apply loads of different magnitudes to the outer joints:

- ◆ Draw a box around the interior top chord joints, as shown below:

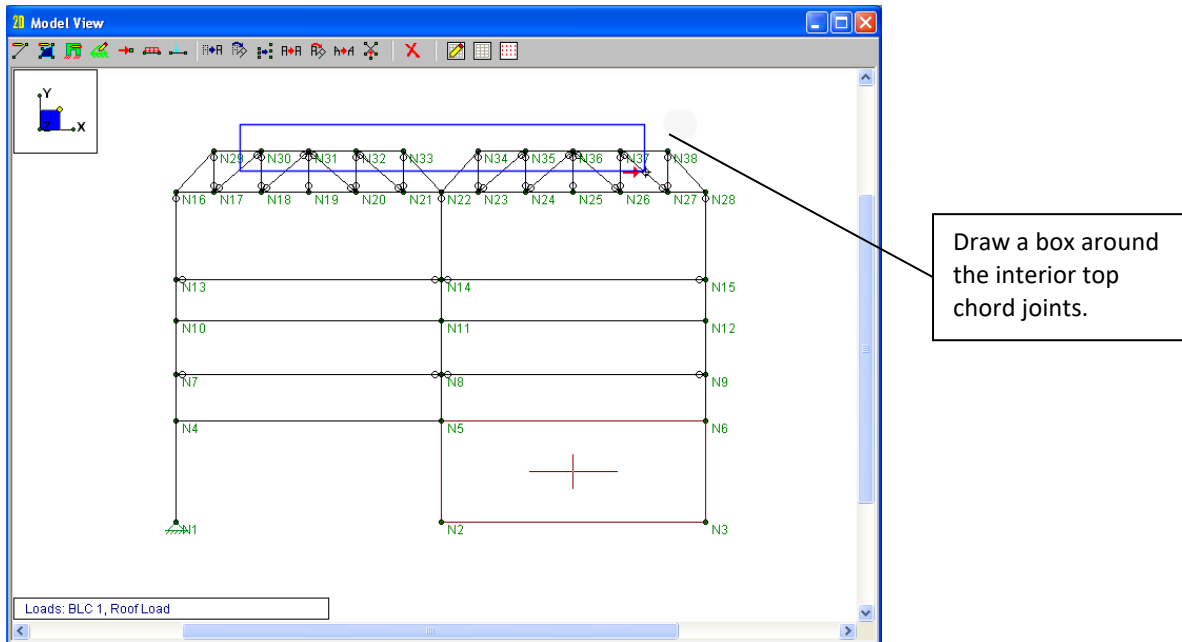

The loads will be applied to the interior joints. If you make any mistakes, click **Undo** .

- ◆ If you cannot see the entire load, click **Zoom Out** .

Return to the **Joint Loads** dialog box and change the magnitude:

- ◆ Press **CTRL+D** to return to the last dialog box.
- ◆ In the **Magnitude** box, type **-2**.
- ◆ Click **Apply**.

Return to your model view. Apply more loads:

- ◆ Click nodes **N29** and **N38** to specify the two exterior panel points on the top chord.

When you are finished your model should look like this:

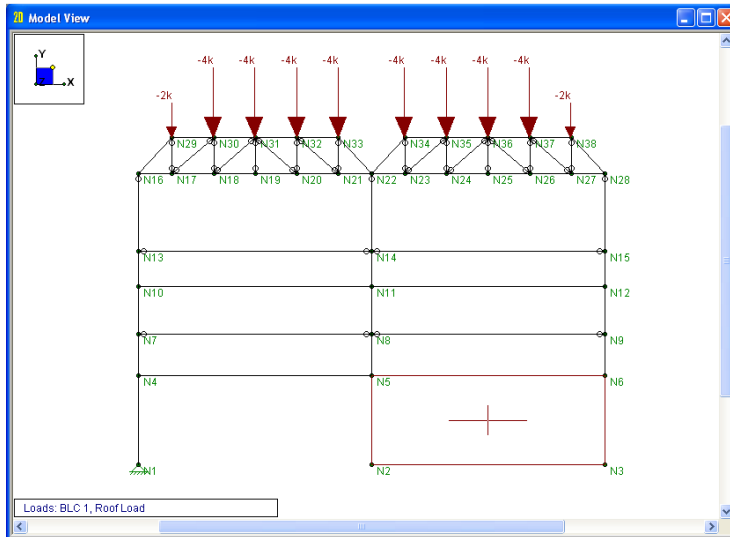

Distributed Loads

The wind load will be applied as a 250 plf distributed load.

Apply these loads by clicking on the members to demonstrate this method.

- ◆ On the Drawing toolbar, click **Distributed Loads** .

The **Distributed Loads** dialog box will display. Apply the settings for the distributed load:

- ◆ In the **Basic Load Case** list, click **2: Wind Load**.
- ◆ In the **Direction** list, click **X**.
- ◆ In the **Start Magnitude** box, type **-0.25** (notice the same value is automatically entered as the **End Magnitude** value.)
- ◆ Under **What Happens When Apply is Pressed?** click **Apply Load By Clicking Members/Wall Panel Edges Individually**.

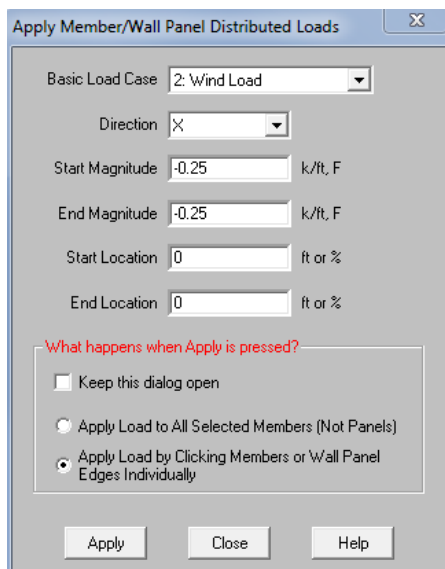

Tutorial 3 - Loading

Close the dialog box and prepare to select the members.

- ◆ Click **Apply**.

To apply the load, return to your model view and select the members:

- ◆ Click the steel column on the right side. The loading will be applied.
- ◆ Right-click the mouse to exit the drawing mode.

Your model should now look like this:

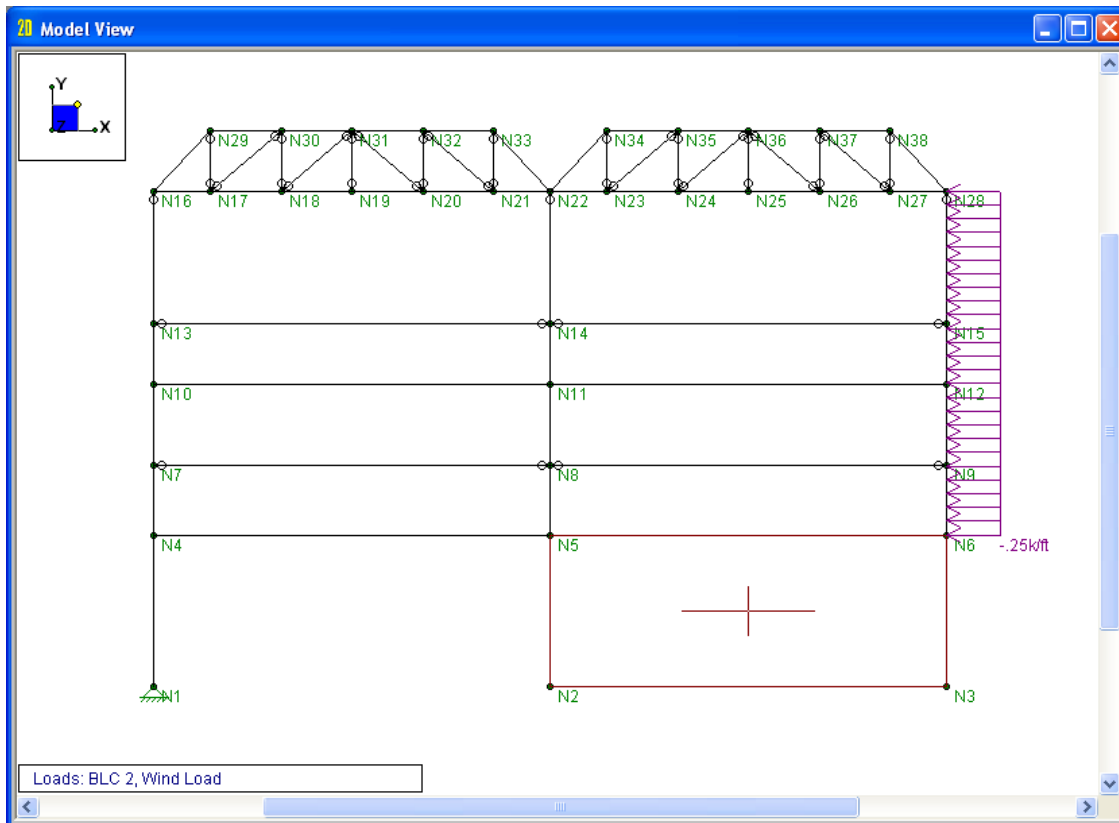

Basic Load Case Spreadsheet

To verify that the loads you applied graphically are correct, review them in the spreadsheets.

- ◆ On the **Spreadsheets** menu, select **Basic Load Cases** to open the **Basic Load Cases** spreadsheet.

The **Basic Load Cases** spreadsheet is where you named your Basic Load Cases earlier. Notice that there are now some numbers on the right side of the spreadsheet. These numbers summarize the loads you just defined. In row **1**, in the **Joint** column, the **10** represents the 10 joint loads that you placed in the Roof Load case. The **1** in the **Distributed** column represents the distributed wind load.

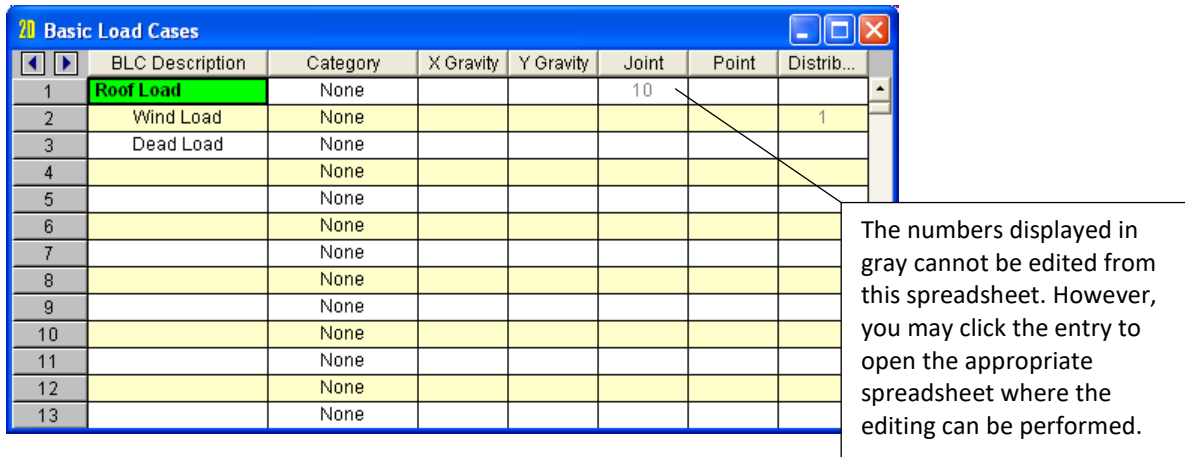

	BLC Description	Category	X Gravity	Y Gravity	Joint	Point	Distrib...
1	Roof Load	None			10		
2	Wind Load	None					1
3	Dead Load	None					
4		None					
5		None					
6		None					
7		None					
8		None					
9		None					
10		None					
11		None					
12		None					
13		None					

Open the **Joint Loads** spreadsheet to verify the loads that were assigned to **BLC 1**.

- ◆ In row **1**, in the **Joint** column, click the **10**.

The **Joint Loads** spreadsheet opens, displaying the loads that were assigned to BLC 1. Later, you will define the dead load listed on the **Basic Load Case** spreadsheet, and the **Category** and the **Gravity** columns will be explained.

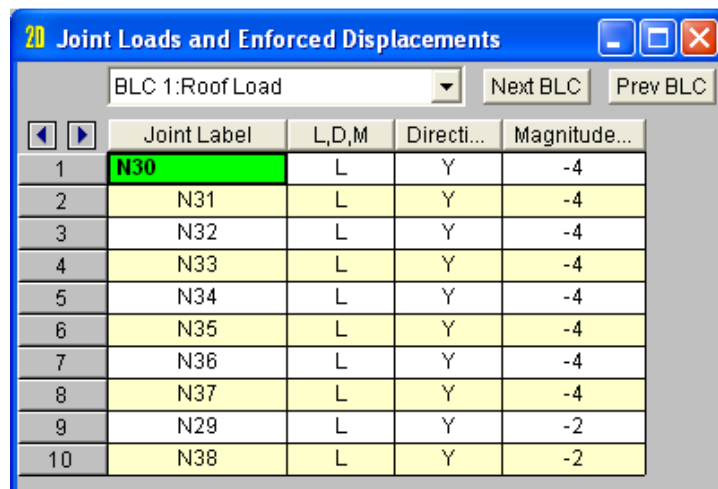

	Joint Label	L,D,M	Directi...	Magnitude...
1	N30	L	Y	-4
2	N31	L	Y	-4
3	N32	L	Y	-4
4	N33	L	Y	-4
5	N34	L	Y	-4
6	N35	L	Y	-4
7	N36	L	Y	-4
8	N37	L	Y	-4
9	N29	L	Y	-2
10	N38	L	Y	-2

For now, close the **Joint Loads** spreadsheet and return to the **Basic Load Cases** spreadsheet:

- ◆ Click **Close**  (or use the shortcut **CTRL+F4**) to close the **Joint Loads** spreadsheet.

Copying Loads

After taking the time to define a complex load case, you may realize that another load case is very similar to it. To save time when defining the second load case, you may find it useful to copy the first load case and modify the copy rather than start from scratch. For this purpose, RISA-2D provides the Copy BLC tool that allows you to copy all or part of a basic load case to another basic load case.

The spreadsheet now defines the roof live load as 10 joint loads. In this step, you will add dead load at the roof level. Because the live load only differs by a factor, use the **Copy BLC** tool to copy the live load into the dead load case, then modify it using the **Block Math** feature:

- ◆ On the Window toolbar, click **Copy BLC** . The **Copy Basic Load Case** dialog box will appear.
- ◆ Under **Copy the Loads FROM this Basic Load Case**, select **1: Roof Load**.
- ◆ Under **INTO this Basic Load Case**, select **3: Dead Load**.

The dialog box should look like this:

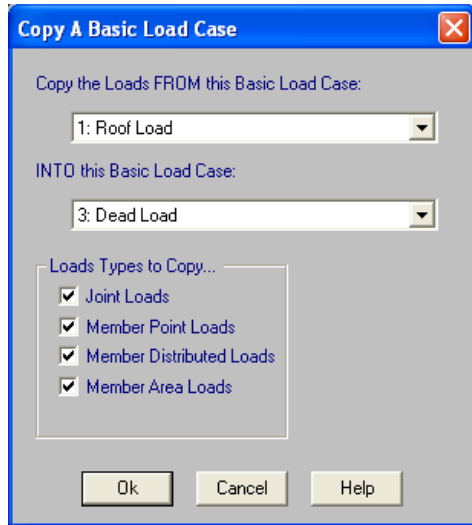

Close the dialog box:

- ◆ Click **OK**.

In row **3**, there should now be a **10** in the **Joint** column.

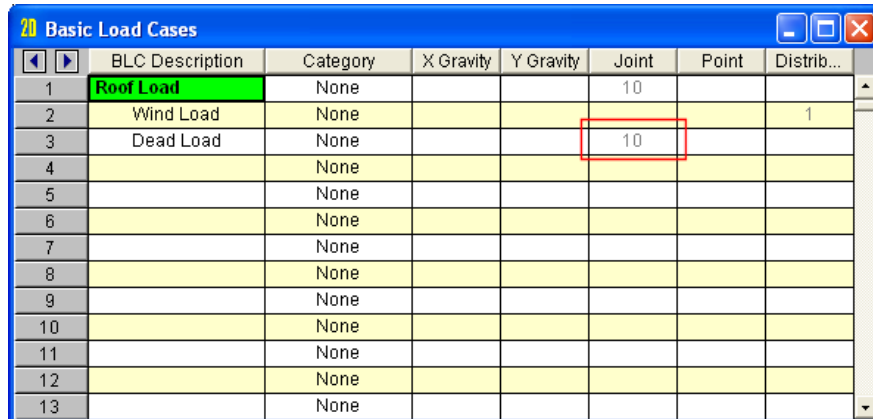

	BLC Description	Category	X Gravity	Y Gravity	Joint	Point	Distrib...
1	Roof Load	None			10		
2	Wind Load	None				1	
3	Dead Load	None			10		
4		None					
5		None					
6		None					
7		None					
8		None					
9		None					
10		None					
11		None					
12		None					
13		None					

Open the **Joint Loads** spreadsheet:

- ◆ On the **Basic Load Cases** spreadsheet, in row 3 (**Dead Load**), in the **Joint** column, click **10** to open the **Joint Loads** spreadsheet for the **Dead Load (BLC 3)**.

Use the **Block Math** feature to change the magnitude of the load so that it represents the correct Dead Load. This can be done with a factor.

- ◆ First, select all of the cells in the **Magnitude** column. A fast way to select the entire column is to click the **Magnitude** column heading. The entire column should now be selected and colored magenta.

	Joint Label	L,D,M	Directi...	Magnitude...
1	N30	L	Y	-4
2	N31	L	Y	-4
3	N32	L	Y	-4
4	N33	L	Y	-4
5	N34	L	Y	-4
6	N35	L	Y	-4
7	N36	L	Y	-4
8	N37	L	Y	-4
9	N29	L	Y	-2
10	N38	L	Y	-2

- ◆ On the Window toolbar, click **Block Math** to open the **Block Math** dialog box.
- ◆ Under **Please enter the block math operand**, type **0.25**. This will make the Dead load 25% of the copied Roof Load.
- ◆ Click **MULTIPLY the block by the operator**.

The dialog box should look like this:

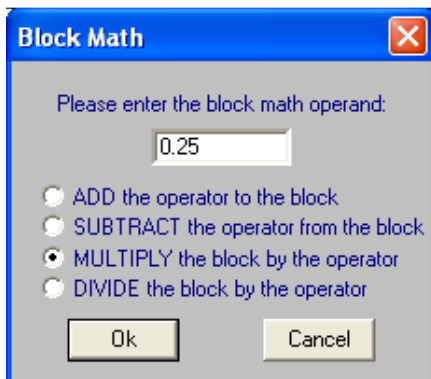

Close the dialog box:

- ◆ Click **Ok**. The joint loads should now have magnitudes of -1K and -0.5K (or one quarter of the Roof Live Load).
- ◆ Click **Close** (or use the shortcut **Ctrl+F4**) to close the **Joint Loads** spreadsheet.

Self-weight

The last step in defining your loads is to define the self weight of the structure. You will add it to the same basic load case where you just placed the surface dead loads. To accomplish this, simply enter a factor in the **Y Gravity** column on the Dead Load Basic Load Case.

- ◆ In row **3 (Dead Load)**, in the **Y Gravity** column, type **-1**.

RISA-2D will now calculate and include the self-weight of the model during solution. The factor entered is a multiplier for the self-weight. In this case, “-1” is used because you want the full self-weight applied downward (the negative Y-direction). You may apply self-weight multipliers in the X or Y direction.

Load Categories

Before you close the **Basic Load Cases** spreadsheet, assign each load case to a Category. Categories are especially helpful in bringing all of your loads together, making it easier to later combine them for solutions. In this model, the loads are quite manageable and you could just refer to them by their BLC number. Many structures, however, will be modeled with multiple separate load cases that are part of the same family.

Assign the associated categories to each basic load cases:

- ◆ In row **1 (Roof Load)**, click in the **Category** column to display the list of available options. Select **RLL (Roof Live Load)**.
- ◆ In row **2 (Wind Load)**, click in the **Category** column. Select **WL (Wind Load)**.
- ◆ In row **3 (Dead Load)**, click in the **Category** column. Select **DL (Dead Load)**.

The spreadsheet is now complete and should look like this:

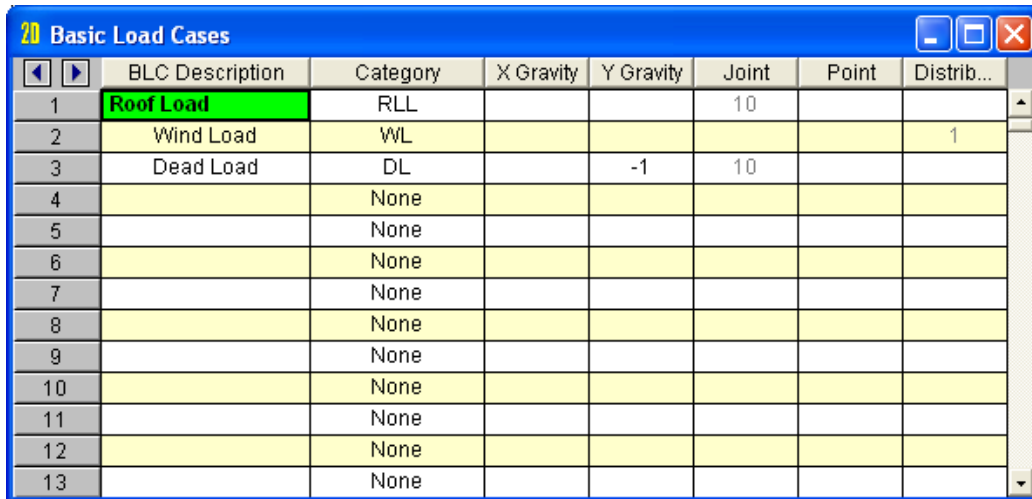

	BLC Description	Category	X Gravity	Y Gravity	Joint	Point	Distrib...
1	Roof Load	RLL			10		
2	Wind Load	WL					1
3	Dead Load	DL		-1	10		
4		None					
5		None					
6		None					
7		None					
8		None					
9		None					
10		None					
11		None					
12		None					
13		None					

Close the spreadsheet:

- ◆ Click **Close** .

Load Combinations

You will now define how the loads are to be combined. These combinations are analyzed when you solve the model and view results. Most standard code combinations are already built into RISA-2D, and accessible through the Load Combination Generator.

Next, you will apply the ASCE minimum design loads and then modify them.

- ◆ On the **Spreadsheets** menu, select **Load Combinations**.

Currently, there is no data available for the spreadsheet. Generate the load combinations using the LC Generator:

- ◆ On the Window toolbar, click the **Load Combination Generator** button .

The **Load Combination Generator** dialog box will display.

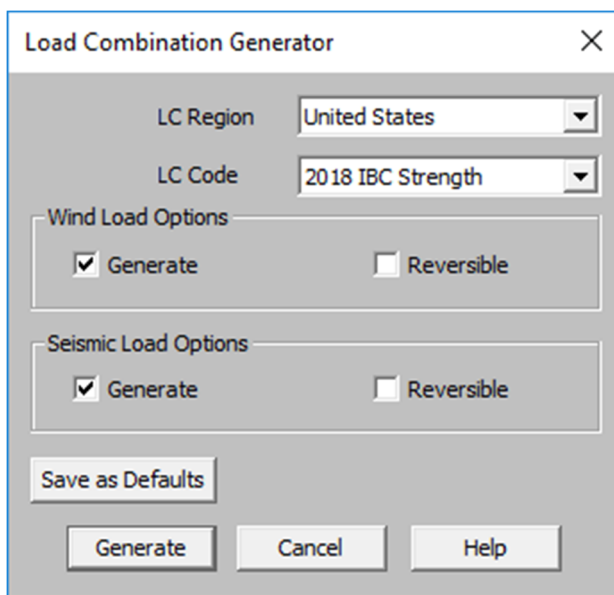

Define the Load Combinations:

- ◆ In the **LC Region** list, click **United States**.
- ◆ In the **LC Code** list, click **2015 IBC ASD**.
- ◆ Under **Wind Load Options**, select the **Generate** check box.
- ◆ Under **Seismic Load Options**, select the **Generate** check box.

Note: For more information on the **Wind Load Options** and **Seismic Load Options** refer to the *Generating Building Code Combinations* section of *RISA-2D General Reference*.

- ◆ Click **Generate**.

Tutorial 3 – Loading

The following Load Combinations will be generated:

2D Load Combinations																
Combinations Design																
	Description	Sol...	PD...	SR...	BLC	Factor	BLC	Factor	BLC	Factor	BLC	Factor	BLC	Factor	BLC	Factor
1	IBC 16-8	<input checked="" type="checkbox"/>			DL	1										
2	IBC 16-9	<input checked="" type="checkbox"/>			DL	1	LL	1	LLS	1						
3	IBC 16-10 (a)	<input checked="" type="checkbox"/>			DL	1	RLL	1								
4	IBC 16-10 (b)	<input checked="" type="checkbox"/>			DL	1	SL	1	SLN	1						
5	IBC 16-10 (c)	<input checked="" type="checkbox"/>			DL	1	RL	1								
6	IBC 16-11 (a)	<input checked="" type="checkbox"/>			DL	1	LL	.75	LLS	.75	RLL	.75				
7	IBC 16-11 (b)	<input checked="" type="checkbox"/>			DL	1	LL	.75	LLS	.75	SL	.75	SLN	.75		
8	IBC 16-11 (c)	<input checked="" type="checkbox"/>			DL	1	LL	.75	LLS	.75	RL	.75				
9	IBC 16-12 (a)	<input checked="" type="checkbox"/>			DL	1	WL	.6								
10	IBC 16-12 (b)	<input checked="" type="checkbox"/>			DL	1	EL	.7								
11	IBC 16-13 (a)	<input checked="" type="checkbox"/>			DL	1	WL	.45	LL	.75	LLS	.75	RLL	.75		
12	IBC 16-13 (b)	<input checked="" type="checkbox"/>			DL	1	WL	.45	LL	.75	LLS	.75	SL	.75	SLN	.75
13	IBC 16-13 (c)	<input checked="" type="checkbox"/>			DL	1	WL	.45	LL	.75	LLS	.75	RL	.75		
14	IBC 16-14 (a)	<input checked="" type="checkbox"/>			DL	1	EL	.525	LL	.75	LLS	.75	RLL	.75		
15	IBC 16-14 (b)	<input checked="" type="checkbox"/>			DL	1	EL	.525	LL	.75	LLS	.75	SL	.75	SLN	.75
16	IBC 16-14 (c)	<input checked="" type="checkbox"/>			DL	1	EL	.525	LL	.75	LLS	.75	RL	.75		
17	IBC 16-15	<input checked="" type="checkbox"/>			DL	.6	WL	.6								
18	IBC 16-16	<input checked="" type="checkbox"/>			DL	.6	EL	.7								

The generated combinations may be edited in the spreadsheet. Each parameter is described below:

Description	Enter a descriptive label, and it will be displayed with the results when the load combination is solved.
Solve	This check box indicates whether this combination is to be included in the Batch or Envelope solution (that will be performed later).
PDelta	The PDelta flag indicates what type of P-Delta analysis you wish to run. P-Delta calculations account for the secondary effects resulting from load eccentricities due to model deflections.
SRSS	The SRSS parameter is used to combine response spectra analysis results for different directions by taking the square root of the sum of the squares.
(the remaining parameters)	The remaining parameters define the actual combinations, with pairs of BLC columns and Factor columns. The values are exactly as listed in the code.

Note: Instead of using categories, as shown, you may also list loads by the BLC number. For example, instead of using **DL**, you could reference the same load by typing the BLC number (**3**). Other options include nesting one combination within another and including response spectra results. For more information, refer to **Help** or *RISA-2D General Reference*.

Because you do not have an earthquake load, snow load, or rain load included in this model, you can remove these unnecessary Load Combinations from the spreadsheet by deleting those rows.

First, select the rows to be deleted:

- Select rows **4** and **5** (load combinations **IBC 16-10 (b)** to **IBC 16-10 (c)**) by clicking directly on row **4** (the row label), then drag down to row **5**. Release the mouse.

The spreadsheet now looks like this.

The screenshot shows a spreadsheet window titled 'Load Combinations' with a 'Design' tab. The spreadsheet has columns for 'Description', 'Sol...', 'PD...', 'SR...', 'BLC', 'Factor', 'BLC', 'Factor', 'BLC', 'Factor', 'BLC', 'Factor', 'BLC', 'Factor', 'BLC', 'Factor'. Rows 4 and 5 are highlighted in yellow. Row 4 is 'IBC 16-10 (b)' and row 5 is 'IBC 16-10 (c)'. A callout box on the right contains the text: 'The rows should now be shaded yellow. Note: If the cells are shaded magenta, you accidentally selected cells from within the spreadsheet instead of the row label. Click Undo and try again.'

	Description	Sol...	PD...	SR...	BLC	Factor	BLC	Factor	BLC	Factor	BLC	Factor	BLC	Factor	BLC	Factor
1	IBC 16-8	<input checked="" type="checkbox"/>			DL	1										
2	IBC 16-9	<input checked="" type="checkbox"/>			DL	1	LL	1	LLS	1						
3	IBC 16-10 (a)	<input checked="" type="checkbox"/>			DL	1	RLL	1								
4	IBC 16-10 (b)	<input checked="" type="checkbox"/>			DL	1	SL	1	SLN	1						
5	IBC 16-10 (c)	<input checked="" type="checkbox"/>			DL	1	RL	1								
6	IBC 16-11 (a)	<input checked="" type="checkbox"/>			DL	1	LL	.75	LLS	.75	RLL	.75				
7	IBC 16-11 (b)	<input checked="" type="checkbox"/>			DL	1	LL	.75	LLS	.75	SL	.75	SLN	.75		
8	IBC 16-11 (c)	<input checked="" type="checkbox"/>			DL	1	LL	.75	LLS	.75	RL					
9	IBC 16-12 (a)	<input checked="" type="checkbox"/>			DL	1	WL	.6								
10	IBC 16-12 (b)	<input checked="" type="checkbox"/>			DL	1	EL	.7								
11	IBC 16-13 (a)	<input checked="" type="checkbox"/>			DL	1	WL	.45	LL	.75	LLS					
12	IBC 16-13 (b)	<input checked="" type="checkbox"/>			DL	1	WL	.45	LL	.75	LLS					
13	IBC 16-13 (c)	<input checked="" type="checkbox"/>			DL	1	WL	.45	LL	.75	LLS					
14	IBC 16-14 (a)	<input checked="" type="checkbox"/>			DL	1	EL	.525	LL	.75	LLS					
15	IBC 16-14 (b)	<input checked="" type="checkbox"/>			DL	1	EL	.525	LL	.75	LLS					
16	IBC 16-14 (c)	<input checked="" type="checkbox"/>			DL	1	EL	.525	LL	.75	LLS					
17	IBC 16-15	<input checked="" type="checkbox"/>			DL	.6	WL	.6								
18	IBC 16-16	<input checked="" type="checkbox"/>			DL	.6	EL	.7								

Now, delete these rows:

- On the Window toolbar, click **Delete Lines** .

Note: After deleting, the row numbers will renumber, and you will be left with 16 combinations.

Tutorial 3 – Loading

Continue by deleting Load Combinations **5 (IBC 16-11 (b))** and **6 (IBC 16-11 (c))**, this time using a different method:

- ◆ In row **5**, click in the **Description** column. Press the F4 key two times to delete rows **5** and **6**.

Delete a few more Load Combinations to finish:

- ◆ Using whichever method you prefer from the above two options, delete the following Load Combinations:

IBC 16-12 (b)

IBC 16-13 (b)

IBC 16-13 (c)

IBC 16-14 (a)

IBC 16-14 (b)

IBC 16-14 (c)

IBC 16-16

- ◆ When finished, verify that your spreadsheet matches this image:

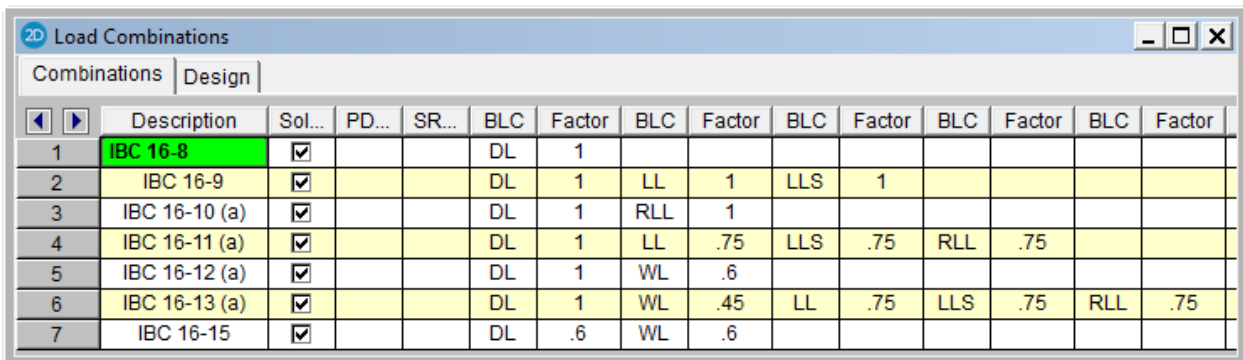

	Description	Sol...	PD...	SR...	BLC	Factor	BLC	Factor	BLC	Factor	BLC	Factor	BLC	Factor
1	IBC 16-8	<input checked="" type="checkbox"/>			DL	1								
2	IBC 16-9	<input checked="" type="checkbox"/>			DL	1	LL	1	LLS	1				
3	IBC 16-10 (a)	<input checked="" type="checkbox"/>			DL	1	RLL	1						
4	IBC 16-11 (a)	<input checked="" type="checkbox"/>			DL	1	LL	.75	LLS	.75	RLL	.75		
5	IBC 16-12 (a)	<input checked="" type="checkbox"/>			DL	1	WL	.6						
6	IBC 16-13 (a)	<input checked="" type="checkbox"/>			DL	1	WL	.45	LL	.75	LLS	.75	RLL	.75
7	IBC 16-15	<input checked="" type="checkbox"/>			DL	.6	WL	.6						

The remaining Load Combinations are sufficient for your steel, wood, aluminum, and masonry elements. However, you will need to add more load combinations for the design of your concrete members.

- ◆ On the Window toolbar, click **Load Combination Generator** **LC Generator** again.

The **Load Combination Generator** dialog box will display again. Define the load combinations:

- ◆ In the **LC Region** list, click **United States**.
- ◆ In the **LC Code** list, click **2015 IBC Strength**.
- ◆ Under **Wind Load Options**, select the **Generate** check box.
- ◆ Under **Seismic Load Options**, click to clear the **Generate** check box. Click **Generate**.

The **Load Combinations** spreadsheet should now look like this:

2D Load Combinations																
Combinations Design																
	Description	Sol...	PD...	SR...	BLC	Factor	BLC	Factor	BLC	Factor	BLC	Factor	BLC	Factor	BLC	Factor
1	IBC 16-8	<input checked="" type="checkbox"/>			DL	1										
2	IBC 16-9	<input checked="" type="checkbox"/>			DL	1	LL	1	LLS	1						
3	IBC 16-10 (a)	<input checked="" type="checkbox"/>			DL	1	RLL	1								
4	IBC 16-11 (a)	<input checked="" type="checkbox"/>			DL	1	LL	.75	LLS	.75	RLL	.75				
5	IBC 16-12 (a)	<input checked="" type="checkbox"/>			DL	1	WL	.6								
6	IBC 16-13 (a)	<input checked="" type="checkbox"/>			DL	1	WL	.45	LL	.75	LLS	.75	RLL	.75		
7	IBC 16-15	<input checked="" type="checkbox"/>			DL	.6	WL	.6								
8	IBC 16-1	<input checked="" type="checkbox"/>	Y		DL	1.4										
9	IBC 16-2 (a)	<input checked="" type="checkbox"/>	Y		DL	1.2	LL	1.6	LLS	1.6	RLL	.5				
10	IBC 16-2 (b)	<input checked="" type="checkbox"/>	Y		DL	1.2	LL	1.6	LLS	1.6	SL	.5	SLN	.5		
11	IBC 16-2 (c)	<input checked="" type="checkbox"/>	Y		DL	1.2	LL	1.6	LLS	1.6	RL	.5				
12	IBC 16-3 (a)	<input checked="" type="checkbox"/>	Y		DL	1.2	RLL	1.6	LL	.5	LLS	1				
13	IBC 16-3 (b)	<input checked="" type="checkbox"/>	Y		DL	1.2	RLL	1.6	WL	.5						
14	IBC 16-3 (c)	<input checked="" type="checkbox"/>	Y		DL	1.2	SL	1.6	SLN	1.6	LL	.5	LLS	1		
15	IBC 16-3 (d)	<input checked="" type="checkbox"/>	Y		DL	1.2	SL	1.6	SLN	1.6	WL	.5				
16	IBC 16-3 (e)	<input checked="" type="checkbox"/>	Y		DL	1.2	RL	1.6	LL	.5	LLS	1				
17	IBC 16-3 (f)	<input checked="" type="checkbox"/>	Y		DL	1.2	RL	1.6	WL	.5						
18	IBC 16-4 (a)	<input checked="" type="checkbox"/>	Y		DL	1.2	WL	1	LL	.5	LLS	1	RLL	.5		
19	IBC 16-4 (b)	<input checked="" type="checkbox"/>	Y		DL	1.2	WL	1	LL	.5	LLS	1	SL	.5	SLN	.5
20	IBC 16-4 (c)	<input checked="" type="checkbox"/>	Y		DL	1.2	WL	1	LL	.5	LLS	1	RL	.5		
21	IBC 16-6	<input checked="" type="checkbox"/>	Y		DL	.9	WL	1								

Tutorial 3 – Loading

With the requirements of the current design codes, you will need to include P-Delta effects in your results. This is not always included by default, but you can include it in the **Load Combinations** spreadsheet.

- ◆ Use your cursor to highlight the **PDelta** column for all rows.
- ◆ Click CTRL + F to open the **Block Fill** dialog box.
- ◆ Type “Y” into the dialog box and click **Ok**.

This will fill in the **P-Delta** column with **Y**, representing a “Yes, include P-Delta effects” for the steel design load combinations.

2D Load Combinations																
Combinations Design																
	Description	Sol...	PD...	SR...	BLC	Factor	BLC	Factor	BLC	Factor	BLC	Factor	BLC	Factor	BLC	Factor
1	IBC 16-8	<input checked="" type="checkbox"/>	Y		DL	1										
2	IBC 16-9	<input checked="" type="checkbox"/>	Y		DL	1	LL	1	LLS	1						
3	IBC 16-10 (a)	<input checked="" type="checkbox"/>	Y		DL	1	RLL	1								
4	IBC 16-11 (a)	<input checked="" type="checkbox"/>	Y		DL	1	LL	.75	LLS	.75	RLL	.75				
5	IBC 16-12 (a)	<input checked="" type="checkbox"/>	Y		DL	1	WL	.6								
6	IBC 16-13 (a)	<input checked="" type="checkbox"/>	Y		DL	1	WL	.45	LL	.75	LLS	.75	RLL	.75		
7	IBC 16-15	<input checked="" type="checkbox"/>	Y		DL	.6	WL	.6								
8	IBC 16-1	<input checked="" type="checkbox"/>	Y		DL	1.4										
9	IBC 16-2 (a)	<input checked="" type="checkbox"/>	Y		DL	1.2	LL	1.6	LLS	1.6	RLL	.5				
10	IBC 16-2 (b)	<input checked="" type="checkbox"/>	Y		DL	1.2	LL	1.6	LLS	1.6	SL	.5	SLN	.5		
11	IBC 16-2 (c)	<input checked="" type="checkbox"/>	Y		DL	1.2	LL	1.6	LLS	1.6	RL	.5				
12	IBC 16-3 (a)	<input checked="" type="checkbox"/>	Y		DL	1.2	RLL	1.6	LL	.5	LLS	1				
13	IBC 16-3 (b)	<input checked="" type="checkbox"/>	Y		DL	1.2	RLL	1.6	WL	.5						
14	IBC 16-3 (c)	<input checked="" type="checkbox"/>	Y		DL	1.2	SL	1.6	SLN	1.6	LL	.5	LLS	1		
15	IBC 16-3 (d)	<input checked="" type="checkbox"/>	Y		DL	1.2	SL	1.6	SLN	1.6	WL	.5				
16	IBC 16-3 (e)	<input checked="" type="checkbox"/>	Y		DL	1.2	RL	1.6	LL	.5	LLS	1				
17	IBC 16-3 (f)	<input checked="" type="checkbox"/>	Y		DL	1.2	RL	1.6	WL	.5						
18	IBC 16-4 (a)	<input checked="" type="checkbox"/>	Y		DL	1.2	WL	1	LL	.5	LLS	1	RLL	.5		
19	IBC 16-4 (b)	<input checked="" type="checkbox"/>	Y		DL	1.2	WL	1	LL	.5	LLS	1	SL	.5	SLN	.5
20	IBC 16-4 (c)	<input checked="" type="checkbox"/>	Y		DL	1.2	WL	1	LL	.5	LLS	1	RL	.5		
21	IBC 16-6	<input checked="" type="checkbox"/>	Y		DL	.9	WL	1								

Review the Design settings:

- ◆ Click the **Design** tab to view more Load Combination data.
- ◆ Highlight the **Hot Rolled** and **Cold Formed** column checkboxes for lines **8-21** (the Strength load combinations) and use the **Fill Block** command (CTRL+F) to uncheck them all. This way, these members will not be designed for strength level combinations.

	Description	ASIF	CD	ABIF	Service	Hot Rolled	Cold Form...	Wood	Concrete	Masonry	Footings	Aluminum
1	IBC 16-8		.9		<input checked="" type="checkbox"/>	<input checked="" type="checkbox"/>	<input checked="" type="checkbox"/>	<input checked="" type="checkbox"/>	<input checked="" type="checkbox"/>	<input checked="" type="checkbox"/>	<input checked="" type="checkbox"/>	<input checked="" type="checkbox"/>
2	IBC 16-9				<input checked="" type="checkbox"/>	<input checked="" type="checkbox"/>	<input checked="" type="checkbox"/>	<input checked="" type="checkbox"/>	<input checked="" type="checkbox"/>	<input checked="" type="checkbox"/>	<input checked="" type="checkbox"/>	<input checked="" type="checkbox"/>
3	IBC 16-10 (a)		1.25		<input checked="" type="checkbox"/>	<input checked="" type="checkbox"/>	<input checked="" type="checkbox"/>	<input checked="" type="checkbox"/>	<input checked="" type="checkbox"/>	<input checked="" type="checkbox"/>	<input checked="" type="checkbox"/>	<input checked="" type="checkbox"/>
4	IBC 16-11 (a)		1.25		<input checked="" type="checkbox"/>	<input checked="" type="checkbox"/>	<input checked="" type="checkbox"/>	<input checked="" type="checkbox"/>	<input checked="" type="checkbox"/>	<input checked="" type="checkbox"/>	<input checked="" type="checkbox"/>	<input checked="" type="checkbox"/>
5	IBC 16-12 (a)		1.6		<input checked="" type="checkbox"/>	<input checked="" type="checkbox"/>	<input checked="" type="checkbox"/>	<input checked="" type="checkbox"/>	<input checked="" type="checkbox"/>	<input checked="" type="checkbox"/>	<input checked="" type="checkbox"/>	<input checked="" type="checkbox"/>
6	IBC 16-13 (a)		1.6		<input checked="" type="checkbox"/>	<input checked="" type="checkbox"/>	<input checked="" type="checkbox"/>	<input checked="" type="checkbox"/>	<input checked="" type="checkbox"/>	<input checked="" type="checkbox"/>	<input checked="" type="checkbox"/>	<input checked="" type="checkbox"/>
7	IBC 16-15		1.6		<input checked="" type="checkbox"/>	<input checked="" type="checkbox"/>	<input checked="" type="checkbox"/>	<input checked="" type="checkbox"/>	<input checked="" type="checkbox"/>	<input checked="" type="checkbox"/>	<input checked="" type="checkbox"/>	<input checked="" type="checkbox"/>
8	IBC 16-1				<input type="checkbox"/>	<input type="checkbox"/>	<input type="checkbox"/>	<input type="checkbox"/>	<input checked="" type="checkbox"/>	<input checked="" type="checkbox"/>	<input checked="" type="checkbox"/>	<input type="checkbox"/>
9	IBC 16-2 (a)				<input type="checkbox"/>	<input type="checkbox"/>	<input type="checkbox"/>	<input type="checkbox"/>	<input checked="" type="checkbox"/>	<input checked="" type="checkbox"/>	<input checked="" type="checkbox"/>	<input type="checkbox"/>
10	IBC 16-2 (b)				<input type="checkbox"/>	<input type="checkbox"/>	<input type="checkbox"/>	<input type="checkbox"/>	<input checked="" type="checkbox"/>	<input checked="" type="checkbox"/>	<input checked="" type="checkbox"/>	<input type="checkbox"/>
11	IBC 16-2 (c)				<input type="checkbox"/>	<input type="checkbox"/>	<input type="checkbox"/>	<input type="checkbox"/>	<input checked="" type="checkbox"/>	<input checked="" type="checkbox"/>	<input checked="" type="checkbox"/>	<input type="checkbox"/>
12	IBC 16-3 (a)				<input type="checkbox"/>	<input type="checkbox"/>	<input type="checkbox"/>	<input type="checkbox"/>	<input checked="" type="checkbox"/>	<input checked="" type="checkbox"/>	<input checked="" type="checkbox"/>	<input type="checkbox"/>
13	IBC 16-3 (b)				<input type="checkbox"/>	<input type="checkbox"/>	<input type="checkbox"/>	<input type="checkbox"/>	<input checked="" type="checkbox"/>	<input checked="" type="checkbox"/>	<input checked="" type="checkbox"/>	<input type="checkbox"/>
14	IBC 16-3 (c)				<input type="checkbox"/>	<input type="checkbox"/>	<input type="checkbox"/>	<input type="checkbox"/>	<input checked="" type="checkbox"/>	<input checked="" type="checkbox"/>	<input checked="" type="checkbox"/>	<input type="checkbox"/>
15	IBC 16-3 (d)				<input type="checkbox"/>	<input type="checkbox"/>	<input type="checkbox"/>	<input type="checkbox"/>	<input checked="" type="checkbox"/>	<input checked="" type="checkbox"/>	<input checked="" type="checkbox"/>	<input type="checkbox"/>
16	IBC 16-3 (e)				<input type="checkbox"/>	<input type="checkbox"/>	<input type="checkbox"/>	<input type="checkbox"/>	<input checked="" type="checkbox"/>	<input checked="" type="checkbox"/>	<input checked="" type="checkbox"/>	<input type="checkbox"/>
17	IBC 16-3 (f)				<input type="checkbox"/>	<input type="checkbox"/>	<input type="checkbox"/>	<input type="checkbox"/>	<input checked="" type="checkbox"/>	<input checked="" type="checkbox"/>	<input checked="" type="checkbox"/>	<input type="checkbox"/>
18	IBC 16-4 (a)				<input type="checkbox"/>	<input type="checkbox"/>	<input type="checkbox"/>	<input type="checkbox"/>	<input checked="" type="checkbox"/>	<input checked="" type="checkbox"/>	<input checked="" type="checkbox"/>	<input type="checkbox"/>
19	IBC 16-4 (b)				<input type="checkbox"/>	<input type="checkbox"/>	<input type="checkbox"/>	<input type="checkbox"/>	<input checked="" type="checkbox"/>	<input checked="" type="checkbox"/>	<input checked="" type="checkbox"/>	<input type="checkbox"/>
20	IBC 16-4 (c)				<input type="checkbox"/>	<input type="checkbox"/>	<input type="checkbox"/>	<input type="checkbox"/>	<input checked="" type="checkbox"/>	<input checked="" type="checkbox"/>	<input checked="" type="checkbox"/>	<input type="checkbox"/>
21	IBC 16-6				<input type="checkbox"/>	<input type="checkbox"/>	<input type="checkbox"/>	<input type="checkbox"/>	<input checked="" type="checkbox"/>	<input checked="" type="checkbox"/>	<input checked="" type="checkbox"/>	<input type="checkbox"/>

- ◆ Repeat for the **Masonry** column checkboxes for lines **8-21** and the **Concrete** column checkboxes for lines **1-7**.

Once, complete, the concrete members will be only be designed per the strength level combinations.

	Description	ASIF	CD	ABIF	Service	Hot Rolled	Cold Form...	Wood	Concrete	Masonry	Footings	Aluminum
1	IBC 16-8		.9		<input checked="" type="checkbox"/>	<input checked="" type="checkbox"/>	<input checked="" type="checkbox"/>	<input checked="" type="checkbox"/>	<input type="checkbox"/>	<input checked="" type="checkbox"/>	<input checked="" type="checkbox"/>	<input checked="" type="checkbox"/>
2	IBC 16-9				<input checked="" type="checkbox"/>	<input checked="" type="checkbox"/>	<input checked="" type="checkbox"/>	<input checked="" type="checkbox"/>	<input type="checkbox"/>	<input checked="" type="checkbox"/>	<input checked="" type="checkbox"/>	<input checked="" type="checkbox"/>
3	IBC 16-10 (a)		1.25		<input checked="" type="checkbox"/>	<input checked="" type="checkbox"/>	<input checked="" type="checkbox"/>	<input checked="" type="checkbox"/>	<input type="checkbox"/>	<input checked="" type="checkbox"/>	<input checked="" type="checkbox"/>	<input checked="" type="checkbox"/>
4	IBC 16-11 (a)		1.25		<input checked="" type="checkbox"/>	<input checked="" type="checkbox"/>	<input checked="" type="checkbox"/>	<input checked="" type="checkbox"/>	<input type="checkbox"/>	<input checked="" type="checkbox"/>	<input checked="" type="checkbox"/>	<input checked="" type="checkbox"/>
5	IBC 16-12 (a)		1.6		<input checked="" type="checkbox"/>	<input checked="" type="checkbox"/>	<input checked="" type="checkbox"/>	<input checked="" type="checkbox"/>	<input type="checkbox"/>	<input checked="" type="checkbox"/>	<input checked="" type="checkbox"/>	<input checked="" type="checkbox"/>
6	IBC 16-13 (a)		1.6		<input checked="" type="checkbox"/>	<input checked="" type="checkbox"/>	<input checked="" type="checkbox"/>	<input checked="" type="checkbox"/>	<input type="checkbox"/>	<input checked="" type="checkbox"/>	<input checked="" type="checkbox"/>	<input checked="" type="checkbox"/>
7	IBC 16-15		1.6		<input checked="" type="checkbox"/>	<input checked="" type="checkbox"/>	<input checked="" type="checkbox"/>	<input checked="" type="checkbox"/>	<input type="checkbox"/>	<input checked="" type="checkbox"/>	<input checked="" type="checkbox"/>	<input checked="" type="checkbox"/>
8	IBC 16-1				<input type="checkbox"/>	<input type="checkbox"/>	<input type="checkbox"/>	<input type="checkbox"/>	<input checked="" type="checkbox"/>	<input type="checkbox"/>	<input checked="" type="checkbox"/>	<input type="checkbox"/>
9	IBC 16-2 (a)				<input type="checkbox"/>	<input type="checkbox"/>	<input type="checkbox"/>	<input type="checkbox"/>	<input checked="" type="checkbox"/>	<input type="checkbox"/>	<input checked="" type="checkbox"/>	<input type="checkbox"/>
10	IBC 16-2 (b)				<input type="checkbox"/>	<input type="checkbox"/>	<input type="checkbox"/>	<input type="checkbox"/>	<input checked="" type="checkbox"/>	<input type="checkbox"/>	<input checked="" type="checkbox"/>	<input type="checkbox"/>
11	IBC 16-2 (c)				<input type="checkbox"/>	<input type="checkbox"/>	<input type="checkbox"/>	<input type="checkbox"/>	<input checked="" type="checkbox"/>	<input type="checkbox"/>	<input checked="" type="checkbox"/>	<input type="checkbox"/>
12	IBC 16-3 (a)				<input type="checkbox"/>	<input type="checkbox"/>	<input type="checkbox"/>	<input type="checkbox"/>	<input checked="" type="checkbox"/>	<input type="checkbox"/>	<input checked="" type="checkbox"/>	<input type="checkbox"/>
13	IBC 16-3 (b)				<input type="checkbox"/>	<input type="checkbox"/>	<input type="checkbox"/>	<input type="checkbox"/>	<input checked="" type="checkbox"/>	<input type="checkbox"/>	<input checked="" type="checkbox"/>	<input type="checkbox"/>
14	IBC 16-3 (c)				<input type="checkbox"/>	<input type="checkbox"/>	<input type="checkbox"/>	<input type="checkbox"/>	<input checked="" type="checkbox"/>	<input type="checkbox"/>	<input checked="" type="checkbox"/>	<input type="checkbox"/>
15	IBC 16-3 (d)				<input type="checkbox"/>	<input type="checkbox"/>	<input type="checkbox"/>	<input type="checkbox"/>	<input checked="" type="checkbox"/>	<input type="checkbox"/>	<input checked="" type="checkbox"/>	<input type="checkbox"/>
16	IBC 16-3 (e)				<input type="checkbox"/>	<input type="checkbox"/>	<input type="checkbox"/>	<input type="checkbox"/>	<input checked="" type="checkbox"/>	<input type="checkbox"/>	<input checked="" type="checkbox"/>	<input type="checkbox"/>
17	IBC 16-3 (f)				<input type="checkbox"/>	<input type="checkbox"/>	<input type="checkbox"/>	<input type="checkbox"/>	<input checked="" type="checkbox"/>	<input type="checkbox"/>	<input checked="" type="checkbox"/>	<input type="checkbox"/>
18	IBC 16-4 (a)				<input type="checkbox"/>	<input type="checkbox"/>	<input type="checkbox"/>	<input type="checkbox"/>	<input checked="" type="checkbox"/>	<input type="checkbox"/>	<input checked="" type="checkbox"/>	<input type="checkbox"/>
19	IBC 16-4 (b)				<input type="checkbox"/>	<input type="checkbox"/>	<input type="checkbox"/>	<input type="checkbox"/>	<input checked="" type="checkbox"/>	<input type="checkbox"/>	<input checked="" type="checkbox"/>	<input type="checkbox"/>
20	IBC 16-4 (c)				<input type="checkbox"/>	<input type="checkbox"/>	<input type="checkbox"/>	<input type="checkbox"/>	<input checked="" type="checkbox"/>	<input type="checkbox"/>	<input checked="" type="checkbox"/>	<input type="checkbox"/>
21	IBC 16-6				<input type="checkbox"/>	<input type="checkbox"/>	<input type="checkbox"/>	<input type="checkbox"/>	<input checked="" type="checkbox"/>	<input type="checkbox"/>	<input checked="" type="checkbox"/>	<input type="checkbox"/>

Tutorial 3 – Loading

The data from the **Design** tab is described below:

ASIF	Used to enter the allowable stress increase factor (ASIF) for the design of hot rolled steel per <i>AISC 9th Edition</i> specifications. Since you are using the ASCE load combinations, this increase factor (usually 1.333 for wind or seismic loads) will not be used. An entry in this field greater than 1.0 is also used to indicate whether the seismic provisions of the LRFD code are to be used.
CD	The load duration factor used only in NDS wood design. This factor is dependent on the load with the shortest duration that is present in the load combination.
ABIF	Used to enter the Allowable Bearing Increase Factor for footing design (if you have RISAFoot also installed).
Service	This check box indicates whether the load combination is for service level loads. This will affect the stiffness used for concrete members during the solution.
(the remaining parameters)	The remaining parameters define which material types will be designed and/or checked for that load combination. Therefore, you will never get an NDS wood code check for the strength level load combinations used for concrete design.

Review, then close the spreadsheet.

- ◆ Review the information on your spreadsheet to make sure the design data is the same as above.
- ◆ Click **Close** .

Displaying Loads

RISA-2D provides easy ways to view your loads using the loads display buttons described below. The loads can be displayed as Basic Load Cases, Load Categories, or Load Combinations.

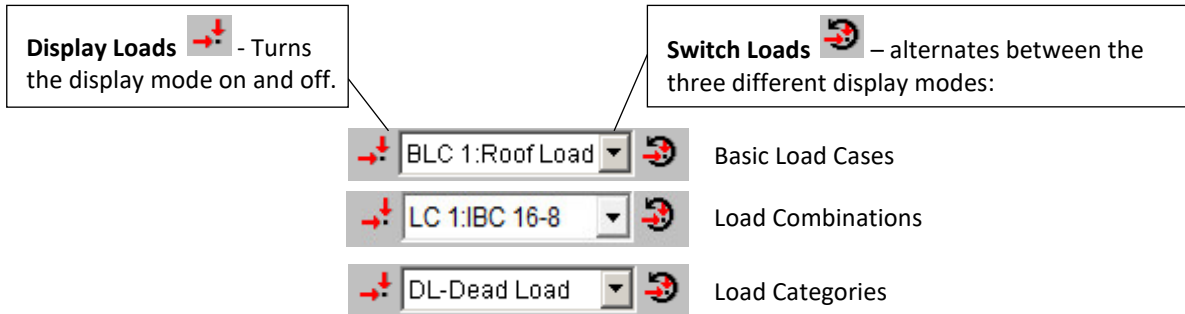

To view the Basic Load Cases, first return to the original model view:

- ◆ Select **Single View** from the Window menu.
- ◆ On the Window toolbar, click **Display Loads** and select **BLC 2:Wind Load**. If your loads do not appear, click **Display Loads** once more to toggle them on.

To view the Load Combinations:

- ◆ On the Window toolbar, click **Switch Loads** one time.

Now you have the option to select any of the Load Combinations from your **Load Combinations** spreadsheet. This view will combine and factor the loads per the selected Load Combination.

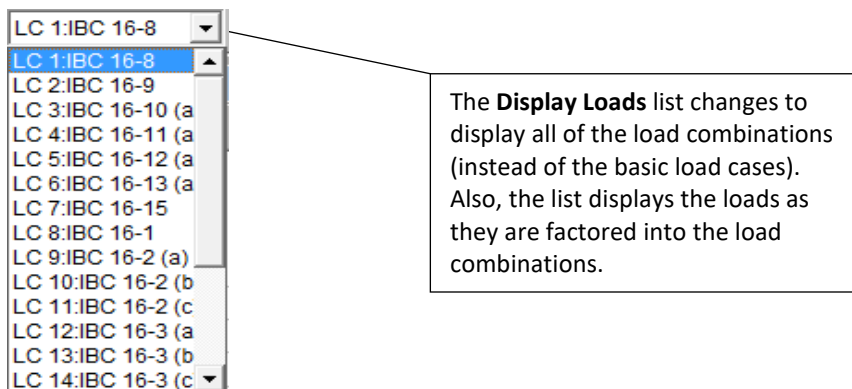

Tutorial 3 – Loading

- ◆ Select **LC 5: ASCE ASD 5 (a)**.

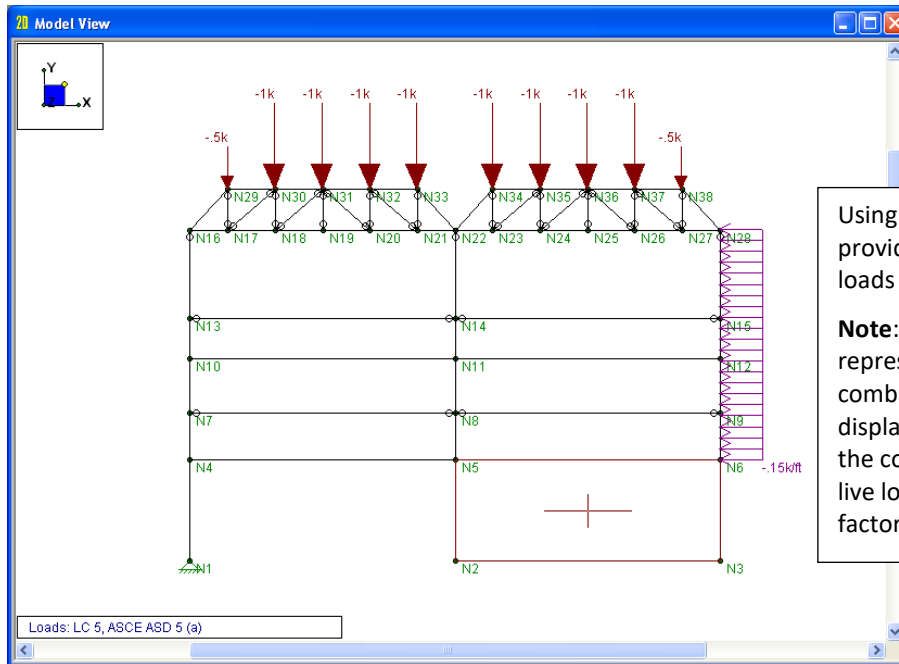

When you are finished viewing the Load Combinations, view the Load Categories:

- ◆ On the Window toolbar, click **Switch Loads**  one more time. The **Display Loads** list will again change, now displaying the Load Categories.
- ◆ View the loads by category by selecting them from the list.

This is the end of Tutorial 3. The next tutorial demonstrates how to solve the model.

You can save your model to be used as the starting point for the next tutorial, or begin the next tutorial using the .r2d starter file in the RISA-2D **Tutorials** folder. To save the model:



- ◆ On the **File** menu, click **Save As** and enter a file name.

Tutorial 4 – Solving & Results





Overview

The last step in the modeling process is to solve the model and review the results. RISA-2D presents results in several ways. You may view the data in the spreadsheets, view a member detail report, or view the results graphically. This tutorial continues where the previous tutorial ended, so follow these steps to get your model up and running:

If you are continuing from the previous tutorial:

- ◆ From the **Window** menu, select **Single View**.
- ◆ On the Window toolbar, click the **Graphic Editing Toolbar** button  to activate the Drawing toolbar.
- ◆ On the **Data Entry** toolbar, click **Close**  to close it.
- ◆ Skip ahead to the next page.

-OR- If you are starting here from scratch, follow the steps below to load the starter file provided by RISA Technologies:

- ◆ Double-click the **RISA-2D** icon to start the program. The **Starting a Model** dialog box will display.
- ◆ Click **Open Model** . Double-click the **Tutorials** folder, select **RISA-2D Tutorial 4 Starter.r2d** and click **Open**.
- ◆ Click **Close**  (or **Cancel**) to exit the **(Global) Model Settings** dialog box.
- ◆ On the Window toolbar, click the **Graphic Editing Toolbar** button  to activate the Drawing toolbar.
- ◆ On the **Data Entry** toolbar, click **Close**  to close it.

Your screen should now look like this:

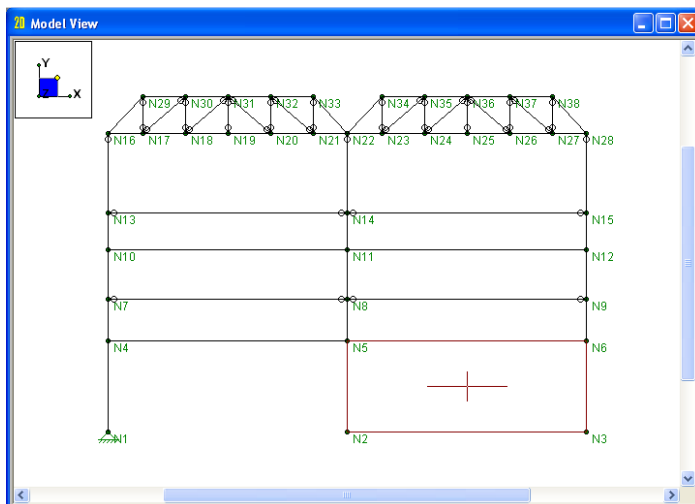

Solve the Model

In this tutorial, you will solve a few single load combinations, then solve all of the combinations and review the enveloped results.

- ◆ On the RISA toolbar, click **Solve** .
- ◆ Click **Single Combination**. In the **Single Combination** list, select **5: IBC 16-12(a)**.

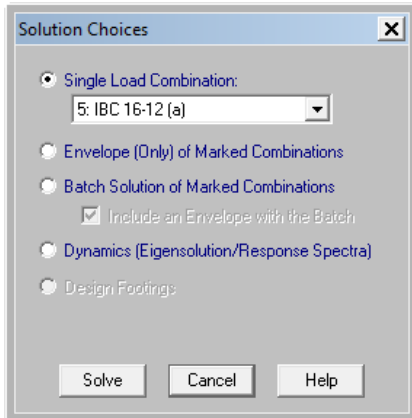

- ◆ Click **Solve**.

RISA-2D reports the solution steps as they occur. When the solution is complete, two new items will display: the **Joint Reactions** spreadsheet and the **Results** toolbar:

The **Results** toolbar contains links to each of the results spreadsheets. (The spreadsheets are also available on the **Results** menu).

2D Joint Reactions (By Combination)

	L...	Joint Label	X [k]	Y [k]	MZ [k-ft]
1	5	N1	-381	7.369	0
2	5	WP1	3.793	25.911	-99.822
3	5	Totals:	3.412	33.28	
4	5	COG (ft):	X: 29.88	Y: 6.921	

Notice the reactions are totaled at the bottom of the spreadsheet. The center of gravity of the vertical loads is reported in the last row.

You may view results in the spreadsheets, plotted on the model view, or review the details for each member, as described below. Use the **Results** toolbar to quickly review the results.

- ◆ On the **Results** toolbar, click some of the spreadsheets.

Now that you have an idea of what results are available, in the next section you will see how easily and quickly you can manipulate them.

- ◆ On the **Results** toolbar, click **Joint Deflections** to review the results.
- ◆ Next, click **Member Forces** to view the **Member Section Forces** spreadsheet. (Note that seven locations are listed for each member. This is because you specified seven sections when defining the **(Global) Model Settings** settings.)

A powerful feature of the spreadsheets is that the data can be sorted various ways. Next, you will use the **Sort** feature to sort the strong axis moment results.

- ◆ Under the **Moment** column, click any cell.
- ◆ On the Window toolbar, click **Sort**  to access the sorting options.
- ◆ Click **Sort Abs Max to Abs Min**.



- ◆ Click **OK**.

The members on the **Member Forces** spreadsheet are now sorted according to their absolute maximum bending moment value. Review the remaining spreadsheet data:

- ◆ On the **Results** toolbar, click **Member Stresses** to view the **Member Section Stresses** spreadsheet.
- ◆ Click **Member Deflections** to view the **Member Section Deflections** spreadsheet. This spreadsheet also shows the deflections as a ratio of member length (the L/y' ratio) providing an easy check against deflection criteria such as $L/360$.
- ◆ Click **Suggested Design** to view the suggested redesign shapes (you will use these later).

Review the **Design Results** data:

- ◆ On the **Results** toolbar, click **Design Results**.
- ◆ Click the **Hot Rolled Steel** tab to view AISC code check data; i.e., ratio of actual to allowable stresses. (Any failing members would be denoted with red text.) The allowable stresses, C_b and C_m values, and controlling equation are listed. If you were performing LRFD-based design, the member strengths would also be listed here (along with the code check value).
- ◆ Click the **Cold Formed Steel** tab to view the cold formed steel code checks. The design strengths P_n and M_n are listed, along with the code check values and controlling equation. Factored design stresses and controlling equation are also listed.
- ◆ Click the **Wood** tab to view the NDS code checks for your wood truss members. The factored design stresses and controlling equation are also listed.
- ◆ Click the **Aluminum** tab to view the aluminum code checks.
- ◆ Concrete results are only available for Envelope solutions. To view the concrete results, solve the model for **Envelope (Only) of Marked Combinations**. Then click the **Concrete Beams** tab and the **Concrete Columns** tab to view the concrete code checks.

Now, finish reviewing the **Results** toolbar data:

- ◆ On the **Results** toolbar, click **Material TakeOff** to view the **Material Takeoff** spreadsheet.

This spreadsheet shows material takeoff information for each material and shape in the model. For each material the shapes are listed with the total length and weight. The total length and weight for each material is summed beneath the listing of shapes.

Graphic Results

Since you have solved the model, you now have several more plotting options. But, you must first clean up your workspace a bit:

- ◆ On the **Window** menu, select **Single View**. All the open spreadsheets will close.
- ◆ Finally, on the **Results** toolbar, click **Close**  to close the toolbar.

Deflected Shapes



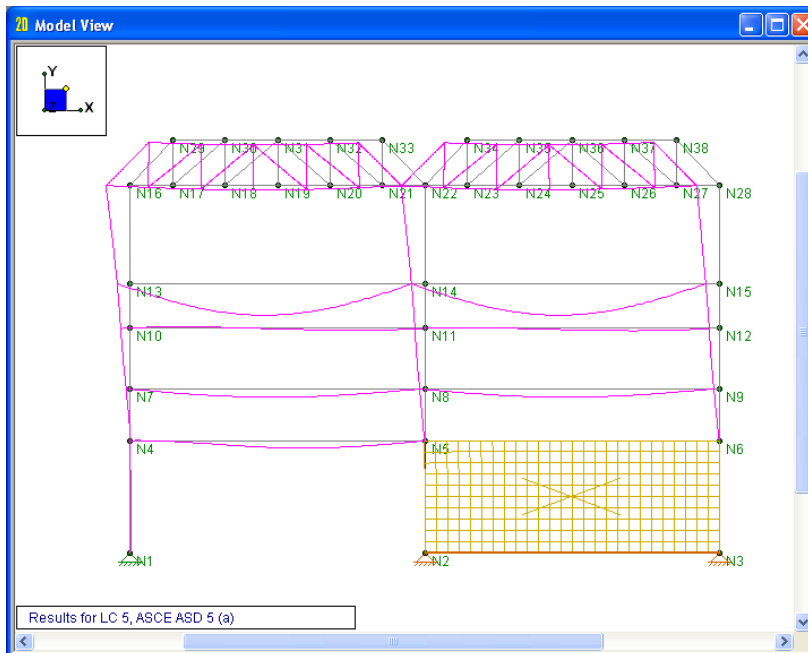

Another important feature to help you quickly review your model is the ability to view deflected shapes. You will utilize this feature next.

- ◆ On the Window toolbar, click **Model Display Options**  to open the **Model Display Options** dialog box.
- ◆ Click the **Deflection** tab.
- ◆ Under **Show Deflected Shape For**, click **Load Combination (pick from list at bottom)**. The combination you solved will now appear in the list at the bottom.
- ◆ Select the **Include Undeformed Shadow** check box.
- ◆ Click **OK**.

Your screen should now look like this:



This is a simple representation of the model deflection under these loads. Next, you will use some of RISA-2D's more advanced graphics features.

- ◆ On the Window menu, click **Joint Labels**  to turn off the joint labels.
- ◆ On the Window toolbar, click **Isometric**  to display the model in isometric view.
- ◆ On the Window toolbar, click **Redraw**  to display the full model view.
- ◆ On the Window toolbar, click **Rendering**  twice.

As you can see, a rendered isometric view offers an excellent view of the model details.

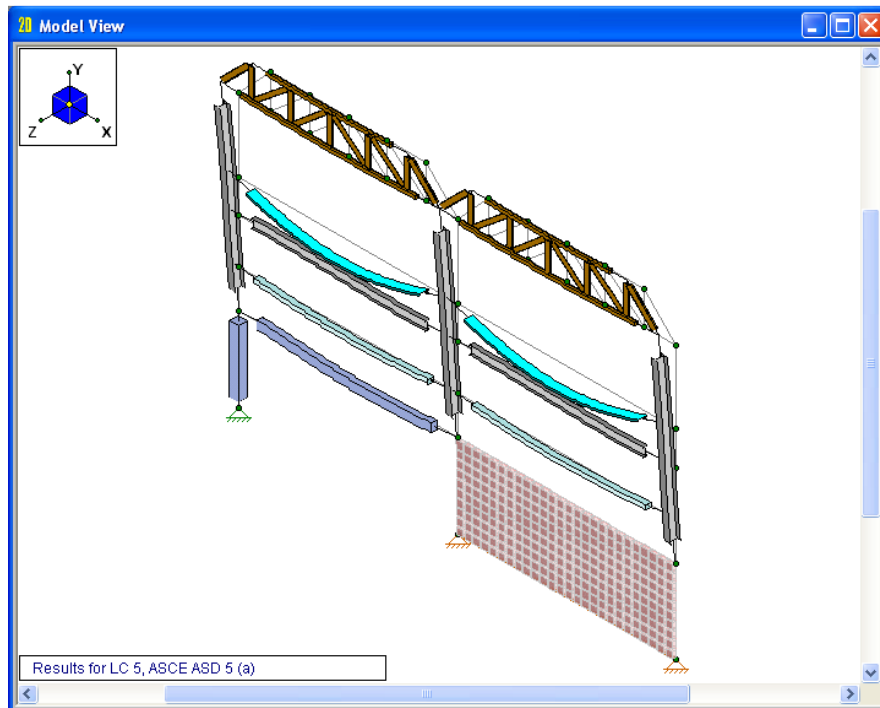

Animation

Now, you can go a step further and animate this deflected shape plot.

- ◆ On the Window toolbar, click **Model Display Options**  again. Make sure you are still on the **Deflection** tab.
- ◆ Click the **Animate This Deflected Shape** button.

A progress bar indicates that the animation is rendering, the speed of which will depend on the speed of your computer. Once your new animation displays, you can close the dialog box.

- ◆ Click **OK** to close the dialog box.

Note: You can change the speed of the animation using the **Faster** or **Slower** buttons. The deflected shape animation is a powerful tool that allows you to clearly see how the model is deflecting, and helps you identify parts of the structure that may have been incorrectly modeled or loaded.

When you are finished watching the animation, close the window:



- ◆ Click the **Close** button to close the animation window.

Color-Coding Member Results

Another important viewing tool is the ability to display members and highlight areas of concern. To demonstrate this, perform a plot of the model with each member color-coded by axial stress.

- ◆ On the Window toolbar, click **Model Display Options**  to return to the **Model Display Options** dialog box. You should still be on the **Deflection** tab.
- ◆ Click **Don't Show Deflected Shape** to turn off the deflected shape.
- ◆ Next, click the **Members** tab.
- ◆ Under **Draw Members As**, select **Color Coded**. Under the **Color Basis** list, select **Compression**.
- ◆ Click **OK**.

Return to an elevation view to better see these color-coded results:

- ◆ On the Window toolbar, click **XY Planar** .
- ◆ On the Window toolbar, click **Redraw** .

The color legend appears in the upper right side of the model view window. With the color-coded members, you can quickly identify members that require further attention.

Display moments and reactions in the model view.

- ◆ On the Window toolbar, click **Model Display Options**  again. You should still be in the **Members** tab.
- ◆ Under **Draw Members As**, select **Wireframe**.
- ◆ Under **Member Results**, in the **Diagram** list, select **Moment**. Ensure that **Transparency** is set to **40%**. Then, select the **Magnitudes** check box.

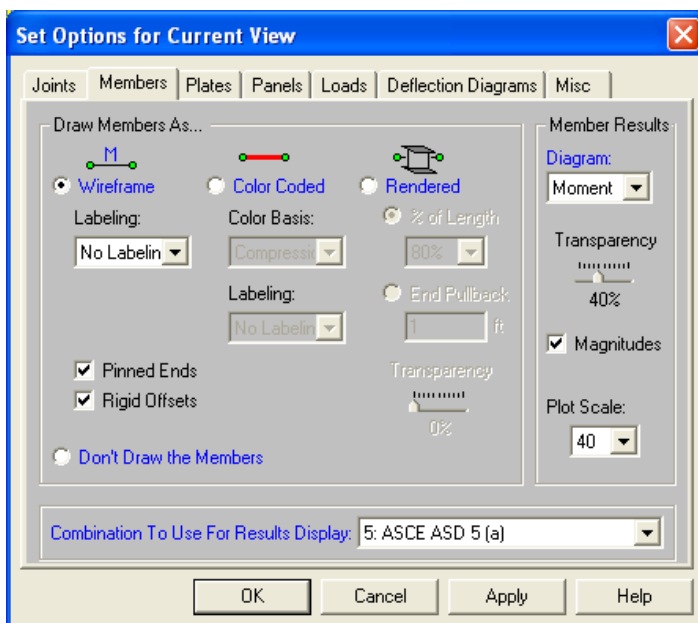

Tutorial 4 – Solving & Results

Modify the Joints settings:

- ◆ Now, click the **Joints** tab.
- ◆ In the **Show the Reactions** section, select the **Y Direction** check box. Then, select the **Include the Magnitudes** check box.
- ◆ Click **OK**.

The moment diagrams and reactions are now plotted with magnitudes, as shown below:

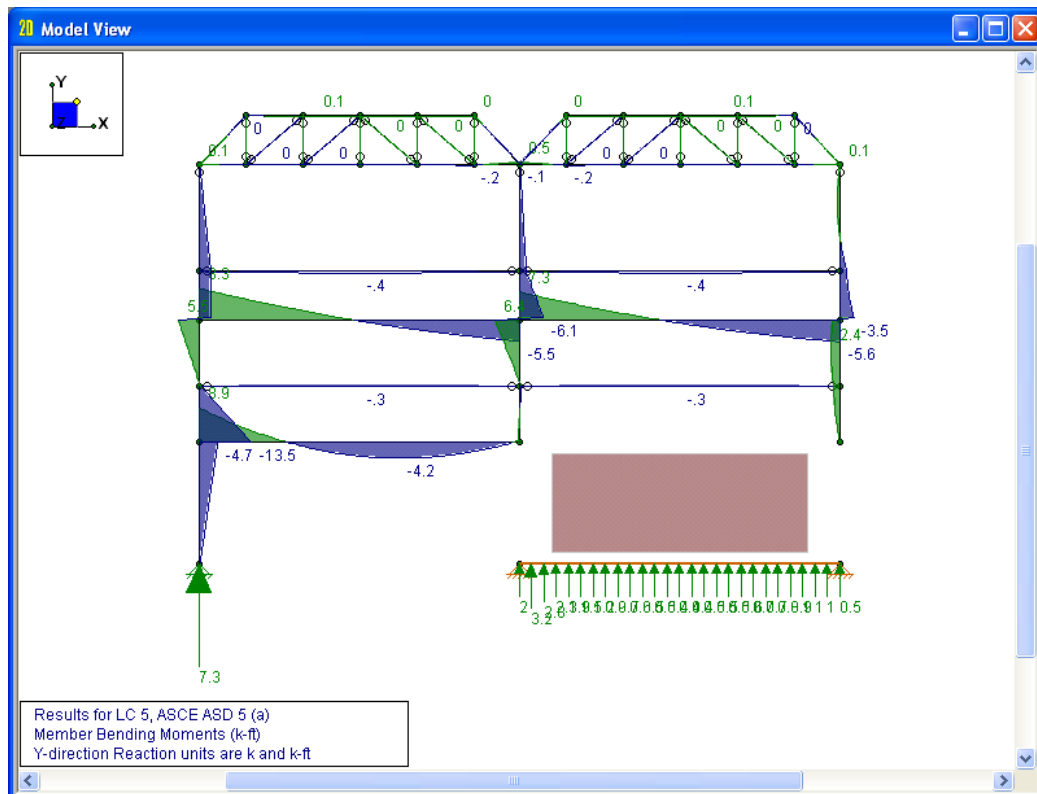

Member Detail Report

Next, use the member detail report to take a closer look at some members.

- ◆ On the **Results** menu, select **Members - Member Detail**.
- ◆ Type **M9**, then click **OK** to display a report on member **M9**

This report will display:

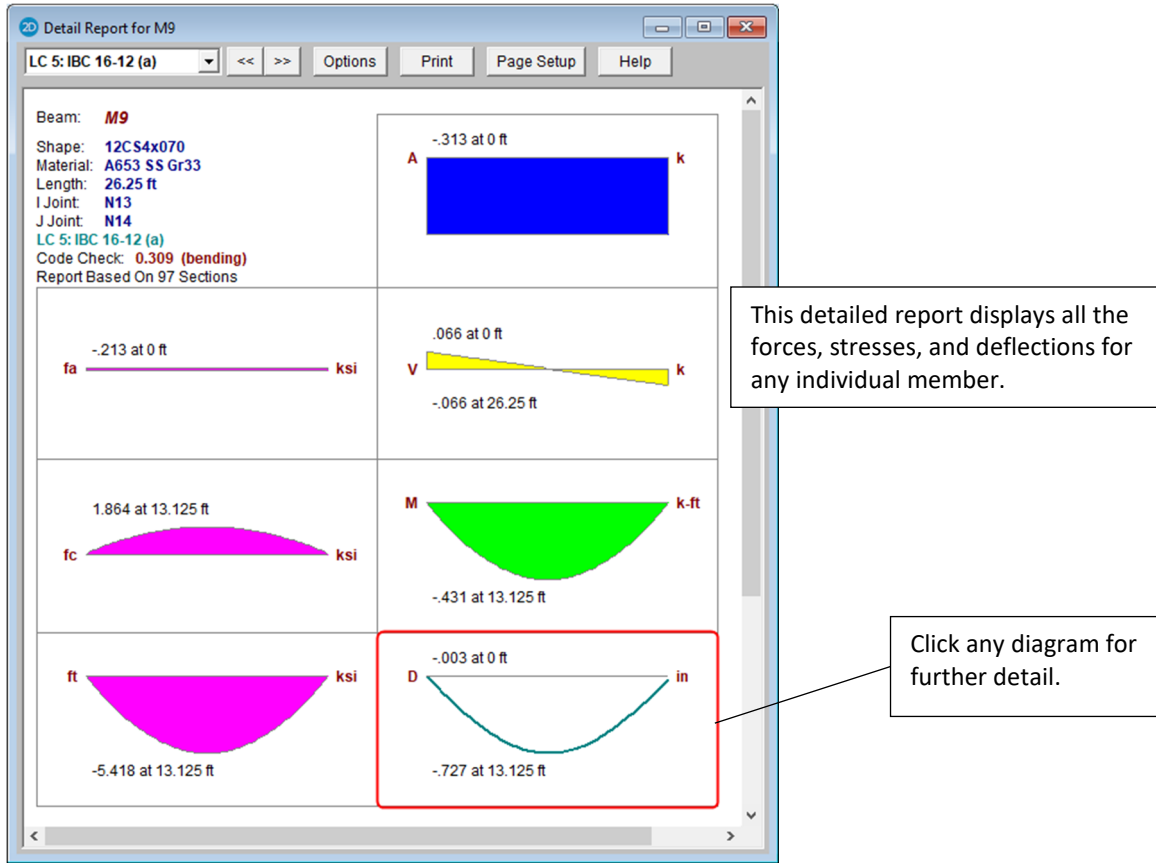

Get even further detail on the deflection diagram:

- ◆ Click the deflection diagram (the lower right diagram).
- ◆ Then press the DOUBLE RIGHT ARROW  two times to display the deflection diagram for Member **M11**.

Tutorial 4 – Solving & Results

The deflection diagram for member **M11** will display:

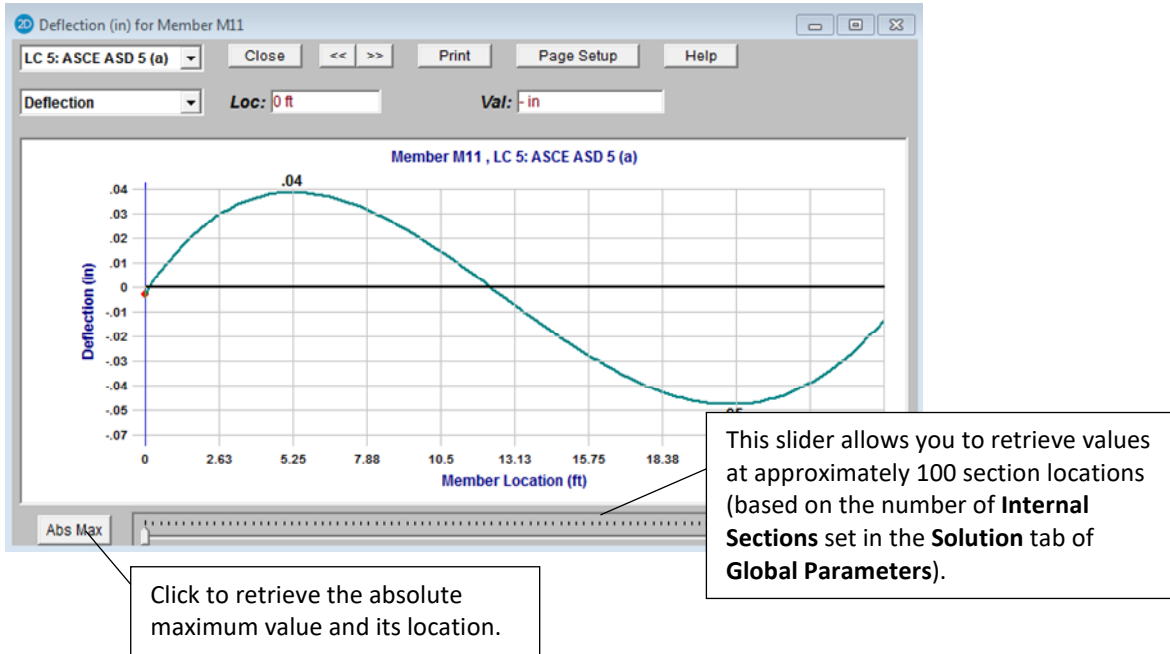

Besides the many ways to navigate these diagrams that are described above, you can also access diagrams for other values without returning to the model view or the detail report.

- ◆ Click the list containing **Deflection**. The entire list of available diagrams will display. Select **Shear Force**.

The shear diagram for member **M11** will display:

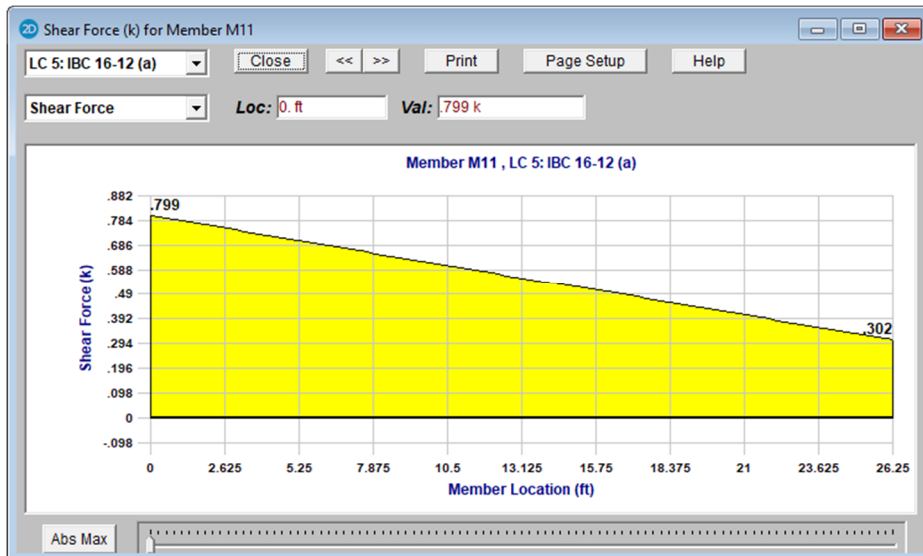

Feel free to try any of the options or view another diagram from the list.

- ◆ When you are finished, click the **Close** button to close any diagrams you may have open.

You will be returned to the member detail report.

- ◆ Scroll down in the detail report to view code check information: code check value along with the controlling equation and all of the design values.
- ◆ Finally, click **Close**  to close the detail report.

You may also open the member detail report by clicking on a member in the model view:

- ◆ On the Selection toolbar, click the **Detail** button. The cursor will now change to . Click any member to generate a report for that member. Try clicking on a few members to see the various detail reports.

You may also open detail reports from within any spreadsheet.



- ◆ From the **Results** menu, select **Members - Design Results**. When the spreadsheet displays, click the **Hot Rolled Steel** tab.
- ◆ On the Window toolbar, click **Detail Report for Current Item**.

Printing Graphic Results

First, return to the model view:

- ◆ On the **Window** menu, select **Single View** to close the extra windows you may have open.
- ◆ Click **Joint Labels**  to turn off the joint labels.

Render the model, then print:

- ◆ On the Window toolbar, click **Model Display Options** . Click the **Members** tab.
- ◆ Under **Draw Members As**, select **Rendered**.
- ◆ Click **OK**.
- ◆ On the RISA toolbar, click **Print** . The **Graphic Print Options** dialog box will appear.
- ◆ Click **Landscape** (paper orientation).

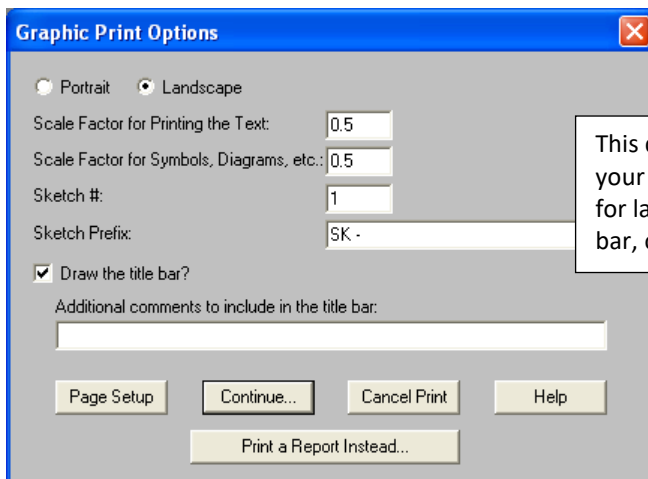

This dialog box allows you to customize your printout by: scaling fonts and symbols for labels and legends, including the title bar, or adding any comments.

- ◆ Click **Continue**. The **Print** dialog box will display. Select your printer, then click **OK** and the plot will be printed.

Tiling Results Windows

RISA-2D provides some very useful window tiling options that will be explored next.

- ◆ On the RISA toolbar, click the **Tiling** button. The **Window Tiling Layouts** dialog box will appear. Use the scroll bar to view the entire list of tiling options. Click **Member Analysis Results**. Click **OK** to accept your tiling selection.
- ◆ On the RISA toolbar, click the **Tiling** button again. This time, select **Three Results Views**. This tiling option allows you to display three views at once. Click **OK**.

Batch Solution

The Batch solution option allows you to solve multiple combinations concurrently, storing the results for all. When using this option, the results for each will be recorded and can then be viewed in the results spreadsheets and organized either by load combination or by item.

- ◆ On the RISA toolbar, click **Solve** again.
- ◆ Select **Batch Solution of Marked Combinations** without Enveloped checkbox checked. Then, click **Solve**. A message will display notifying you that the results will be cleared. Select **Yes**.

Note: Whenever you solve the model, RISA-2D will display a message notifying you that the results will be cleared (you may not want to purge results for a large model that took a fair amount of time to solve). If you would like to disable the warning message, go to the **Tools** menu, click **Application Settings**).

With the Batch solution complete, you may now choose different load combinations when plotting results. Each view may show results from a different combination.

- ◆ Click the lower left view to make it the active window.
- ◆ On the Window toolbar, click **Model Display Options** . You should still be on the **Members** tab.
- ◆ In the **Combination to Use for Results Display** list, select **8: IBC 16-1**. Click **OK**.

The lower left view now shows results for load combination 8.

- ◆ On the **Results** menu, select **Reactions** to display them once again.

For the Batch solution, the spreadsheets display all results for each load combination. Currently, the results are grouped by combination. All reactions for Load Combination 1 are listed first, then for each combination thereafter. The combination number is listed in the first column.

	L...	Joint Label	X [k]	Y [k]	MZ [k-ft]
1	1	N1	.312	6.589	0
2	1	WP1	-.312	26.69	-56.596
3	1	Totals:	0	33.28	
4	1	COG (ft):	X: 29.88	Y: 6.921	
5	2	N1	.312	6.589	0
6	2	WP1	-.312	26.69	-56.596
7	2	Totals:	0	33.28	
8	2	COG (ft):	X: 29.88	Y: 6.921	
9	3	N1	.477	14.887	0
10	3	WP1	-.477	54.393	-202.698
11	3	Totals:	0	69.28	
12	3	COG (ft):	X: 27.994	Y: 17.225	
13	4	N1	.436	12.812	0
14	4	WP1	-.436	47.467	-166.162

You can also group the results so that all the reactions for joint N1 are together, then WP1, etc.

- ◆ On the **Results** menu, select **Results Presentation - Batch Results Listed By Item** to display them joint by joint. The first column shows the load combination.

When performing a batch solution, you have the option to also include a set of envelope results. This is useful when an envelope result is desired to quickly determine a controlling load combination, but when the investigation of that load combination required the greater details given with batch solution results. When using the Batch + Envelope Solution, to view the envelope results, click on a spreadsheet in the Results toolbar. To view the batch results, click on that same spreadsheet in the Results toolbar a second time. Both the envelope and batch solution spreadsheets should now be available simultaneously.

Envelope Solution

An envelope solution differs from a single combination or a batch solution in that it only stores the maximum and minimum values. Each of the spreadsheets will contain minimum and maximum values for each load combination included. Because the rest of the data is not stored, the detail reports and the deflected shapes are not available when this solution type is selected.

Return to the model view, then solve the model again, this time as an envelope solution:

- ◆ On the **Window** menu, click **Single View** to return back to the model view.
- ◆ On the RISA toolbar, click **Solve** .
- ◆ Click **Envelope of Marked Combinations**, then click **Solve**. Click **Yes** to agree to clear the results.
- ◆ Explore several of the spreadsheets to see how the results differ from the batch solution.

Now, take a closer look at your concrete results.

- ◆ On the **Results** menu choose **Members - Design Results**.
- ◆ Click the **Concrete Beams** tab.

Tutorial 4 – Solving & Results

Take a moment to browse these beam results. This spreadsheet presents a maximum code check for the top reinforcing (negative bending), the bottom reinforcing (positive bending), and beam shear, along with the load combination that produced this maximum. In addition, the factored beam capacities are given for each critical location.

◆ Next, click the **Concrete Columns** tab.

The column design results are similar to the beam, except that the bending and shear results are given for *biaxial* loads.

◆ On the Window toolbar, click the **Detail Report for Current Item** button.

This will display an envelope detail report for the concrete column that looks like this:

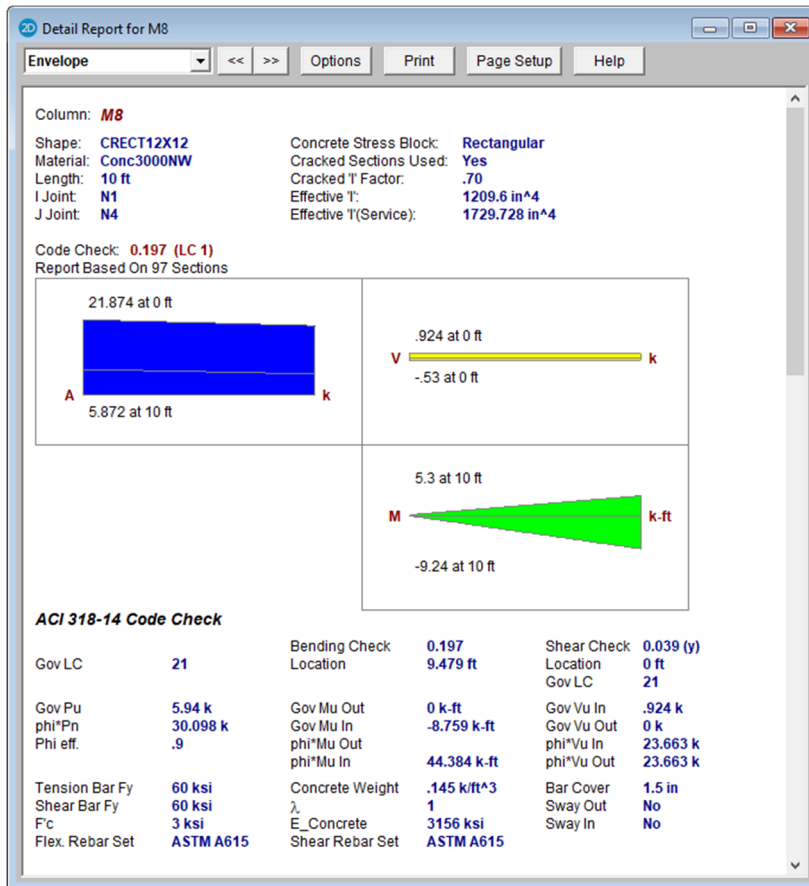

Because this detail report is based on moment and shear envelopes, it is somewhat different than the one you just reviewed for a steel member.

◆ Scroll down to take a look at the interaction diagrams, span information, and reinforcing steel.

In concrete design, each column or beam is divided into spans, depending on how many points of support it has. This portion of the detail report also contains information on the reinforcing steel required for each region of each span.

Code Check Results

RISA-2D offers several ways to review the code check results. You can use a tiling option to organize your screen to include spreadsheet results as well as graphical model views showing the design data.

Change the tiling options:

- ◆ On the RISA toolbar, click **Tiling**. Select **Member Steel Results**, then click **OK**.

Notice the red members in the model view indicate that you have members that are failing the code check. The worst case results are now being reported in the spreadsheet, as a result of the envelope solution you ran. The columns labeled **LC** report the load combination that generated the controlling values. Other results, such as the member forces, display maximum and minimum results in order to capture the worst of both negative and positive results.

Optimizing Member Sizes

The **Suggested Design** spreadsheet reports RISA-2D’s recommendations for alternate shape sizes, along with the member that is controlling the design.

Note: If you are already using the optimum shape for a section set or member, it will not be listed on this spreadsheet.

- ◆ On the **Results** toolbar, click the **Suggested Design** spreadsheet to make it active.

The **Suggested Design** spreadsheet looks like this:

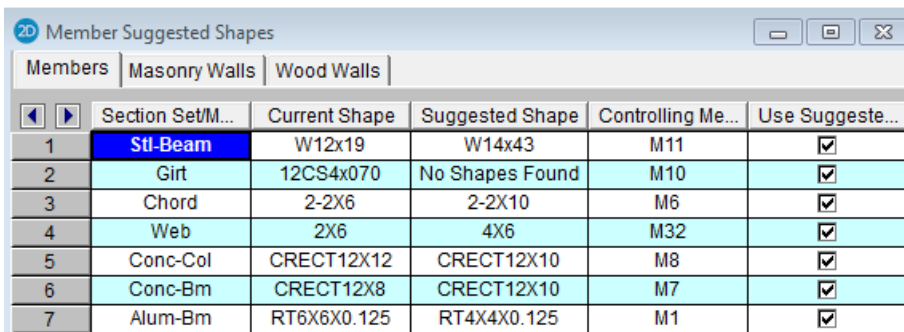

	Section Set/M...	Current Shape	Suggested Shape	Controlling Me...	Use Suggeste...
1	Stl-Beam	W12x19	W14x43	M11	<input checked="" type="checkbox"/>
2	Girt	12CS4x070	No Shapes Found	M10	<input checked="" type="checkbox"/>
3	Chord	2-2X6	2-2X10	M6	<input checked="" type="checkbox"/>
4	Web	2X6	4X6	M32	<input checked="" type="checkbox"/>
5	Conc-Col	CRECT12X12	CRECT12X10	M8	<input checked="" type="checkbox"/>
6	Conc-Bm	CRECT12X8	CRECT12X10	M7	<input checked="" type="checkbox"/>
7	Alum-Bm	RT6X6X0.125	RT4X4X0.125	M1	<input checked="" type="checkbox"/>

Replace and re-solve with the suggested shapes:

- ◆ On the Window toolbar, click **Replace and Resolve** . Then, click **OK** to agree to resolve.

Now only a couple of members are in trouble. For this tutorial, you can simply ignore these last suggestions and move on.

Excluding Spreadsheet Results

Next, you will use the **Wood Code Checks** spreadsheet to sort the members and hide the results for members that have a code check value lower than 0.6. This exemplifies how you can cut down the amount of data for review and verification in your spreadsheets, making it more manageable.

- ◆ On the **Window** menu, click **Single View** to return back to the model view.
- ◆ On the **Results** menu, click **Members**, then click **Design Results**.
- ◆ Click the **Wood** tab. Drag the lower right corner of the window to enlarge it, so that you can view more of the results.

Sort the results based on the maximum code check to reveal which members are closest to failure.

- ◆ On the spreadsheet, click anywhere in the **Code Check** column.
- ◆ On the Window toolbar, click **Sort** , then select **Sort Max to Min**, and click **OK**.

Now, look for the last member with a code check value that is **1.0** or higher (which is in row **4**).

- ◆ Click any cell in row **4**, moving the active cell anywhere on this row.

The active cell is now in row **4**, as shown below:

2D Envelope Wood Code Checks													
Hot Rolled Steel Cold Formed Steel Wood Concrete Beams Concrete Columns Aluminum													
	Member	Shape	Cod...	Lo...	LC	Shea...	Lo...	LC	Fc[ksj]	Ft[ksj]	Fb[ksj]	Fv[ksj]	Eqn
1	M3	2-2X10	1.041	26.25	3	.479	26.25	3	.47	1.38	1.83	.22	3.9-1
2	M4	2-2X10	1.041	0	3	.479	0	3	.47	1.38	1.83	.22	3.9-1
3	M5	2-2X10	1.043	14.06	3	.064	18.75	3	.85	1.38	1.95	.22	3.9-3
4	M6	2-2X10	1.043	4.69	3	.064	0	3	.85	1.38	1.95	.22	3.9-3
5	M16	4X6	.549	0	3	.005	6.16	1	1.09	1.63	2.42	.16	3.6.3
6	M17	4X6	.197	0	3	.005	0	1	1.09	1.63	2.42	.16	3.6.3
7	M18	4X6	.177	0	3	.005	0	1	1.09	1.63	2.42	.16	3.6.3
8	M19	4X6	.564	0	3	.005	6.16	1	1.09	1.63	2.42	.16	3.6.3
9	M20	4X6	.614	0	3	.069	0	3	1.29	1.63	2.43	.22	3.9-3
10	M21	4X6	.564	0	3	.005	6.16	1	1.09	1.63	2.42	.16	3.6.3
11	M22	4X6	.177	0	3	.005	0	1	1.09	1.63	2.42	.16	3.6.3
12	M23	4X6	.197	0	3	.005	0	1	1.09	1.63	2.42	.16	3.6.3

Now, exclude (delete) all the results below row **4**:

- ◆ On the Window toolbar, click **Exclude After** . All rows below the active cell (rows **5** and below) will be deleted from the spreadsheet (keep in mind, you can always click **Unexclude**  to retrieve them).

Printing Results and Spreadsheets

Next, you will explore printing options for the spreadsheets. Because you have excluded some results from the spreadsheet, note that the excluded information will not print.

- ◆ On the RISA toolbar, click **Print**  to open the **Data Printing** dialog box.

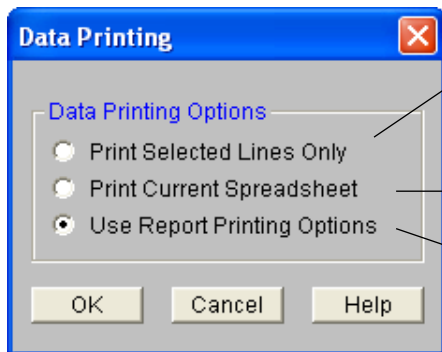

Allows you to print selected lines in a spreadsheet (select the lines you would like printed, then click **Print** .

Select this option to print a single spreadsheet.

This option allows you to print an entire report of your input and/or output.



- ◆ Click **Print Current Spreadsheet**, and click **OK**.

Once you select the printing option you prefer, the **Print** dialog box (for your printer) will display:

- ◆ On the **Print** dialog box, select a printer, and click **OK**. The printer will then print your spreadsheet or report.

Excluding Results Graphically

You can also graphically select items you would like to print using the graphical exclude feature.

- ◆ On the **Window** menu, select **Single View**.
- ◆ On the Window toolbar, click **Member Labels**  to display the member labels.
- ◆ On the Selection toolbar, click **Unselect All** .

Then, make your selection of the items you would like to print:

- ◆ Click one concrete member, one steel member, one wood member, one cold formed steel member, one aluminum member, the wall panel, and two joints.

Your screen should now look something like this:

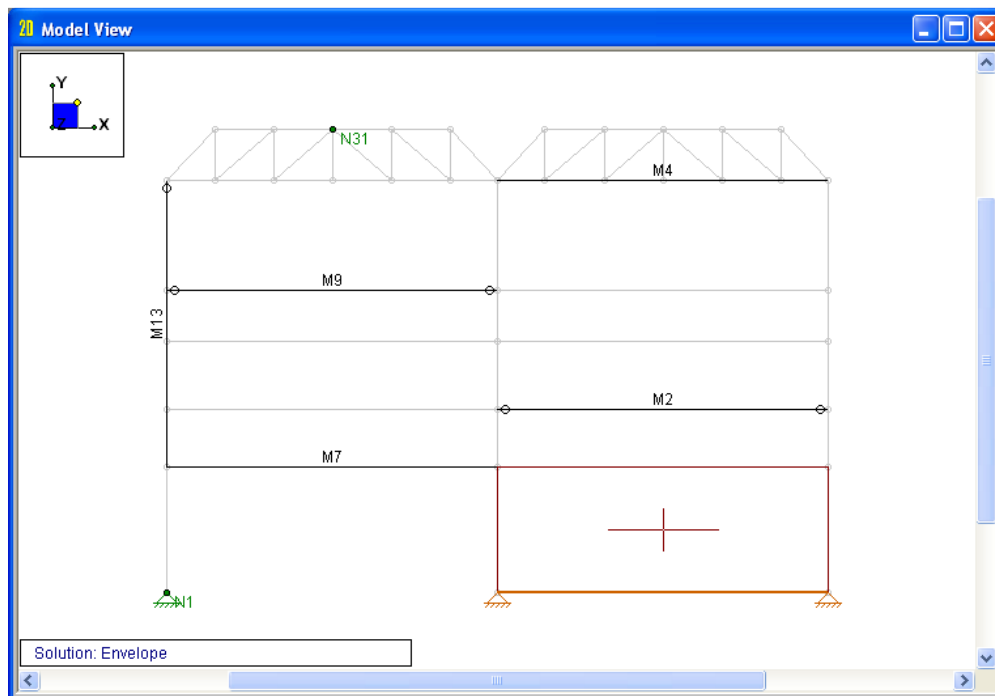

This next step will “exclude” the unselected items from the results:

- ◆ On the Selection toolbar, click **Exclude**. Click **Yes** to exclude the results.

Printing Reports

You have excluded the unselected items from the results spreadsheets. Now it is time to print:

- ◆ On the RISA toolbar, click **Print** .
- ◆ Click **Print a Report Instead**.

The **Report Printing** dialog box will display. As demonstrated below, you can select a standard report (by making a selection from the **Report Name** list) or you can build your own customized report (by making selections from all the available criteria).

- ◆ In the **Report Name** list, select **All Output**.

Notice that when you make this selection, items under **Report Sections** move from the **Available Report Sections** column to the **Sections in Current Report** column. Before you print, remove one more item from the report.

- ◆ Under **Report Sections**, in the **Sections in Current Report** list, double-click **Story Drift, X Service** and **Story Drift, X Strength**. It will now move to the other column, and will not be printed.

The dialog box should now look like this:

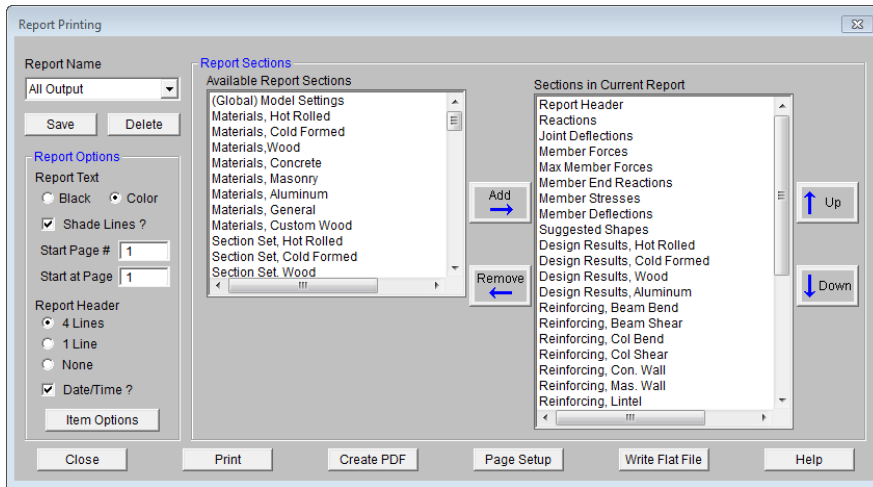

To move a section from one column to the other: highlight the section, and click the **Add** and **Remove** buttons.

Shortcut: Double-click an item to move it from one column to the other.

To adjust the printing order, use the **Up** and **Down** buttons.

Print your customized report:

- ◆ Click the **Print** button (at the bottom of the **Report Printing** dialog box). The **Print** dialog box (for your printer) will display. Click **OK**.
- ◆ Click the **Close** button to close the **Report Printing** dialog box.

This concludes all the tutorials for the RISA-2D User’s Guide. To gain further knowledge, you can go back and increase member sizes, solve different load combinations, or experiment with the plot in other ways.

- ◆ On the **File** menu, click **Exit**.

Conclusion

Congratulations on completing your introductory tour of RISA-2D! The time you invested in performing these tutorials is time well spent. We are confident that the knowledge gained by taking the time to step through these tutorials will increase your productivity, and allow you to complete future projects more quickly and efficiently.

Some features available in RISA-2D, but not covered in this User's Guide are listed below. For more information about any of these features, refer to *RISA-2D General Reference* or the RISA-2D **Help** menu.

























Model Generation	RISA-2D has a library of automatic generators that can quickly generate continuous beams, arcs, trusses, cylinders and numerous mesh layouts of your plate shell element. On the RISA toolbar, click Template  to access this feature.
Moving Loads	The standard AASHTO loads are built into the moving loads database and you can add custom moving loads as well.
Thermal Loads	You can model temperature differentials causing axial expansion or contraction of members.
Dynamics	You can run an eigenvalue solution to determine natural frequencies and mode shapes. You can run a Response Spectra analysis for earthquake loading.
Tension-Compression-Only Members and Springs	These features allow you to model one-way stiffness such as braces that cannot take compression or soil that can only resist compression.
Member Offsets	You may rigidly offset the member ends to model rigid end zones and you may offset the tops of horizontal members to align member tops.
Story Drift, Joint Slaving, and Enforced Displacements	You may calculate and report inter-story drift, slave joints together or specify the displacement at a joint.
Tapered Members and Unequal Flanges	You may specify tapered wide flanges or members with unequal flanges and design them per the Appendix F criteria.

If you have any questions or comments, please contact RISA Technologies by phone at (800) 332-7472, or email at info@risa.com.



























Appendix A – RISA-2D Toolbar Button Quick Reference

RISA Toolbar



Button	Title	Label in RISA-2D	Shortcut
	New Model  Start a new model	Start a new model	(CTRL+N)
	Open Model  Open an existing model	Reload from disk a previous model	(CTRL + O)
	Save  Save current model to disk	Save the current model data to disk	(CTRL+S)
	Copy  Copy to the clipboard	Copy to the clipboard	(CTRL +C)
	Print  Print a report or graphic image	Print a report or graphic image	(CTRL +P)
	Undo  Undo the last operation	Undo the last operation	(CTRL +Z)
	Redo  Reverse the most recent undo operation	Reverse the most recent undo operation	(CTRL +Y)
	Set (Global) Model Settings 	Set (Global) Model Settings	
	Define Units  Define units to be used	Define units to be used	
	Shape Database  Edit the shape database	Edit the shape database	
	Moving Load Patterns  View/edit the moving load patterns	View/Edit the moving load patterns	
	Response Spectra Library  Edit the response spectra library	Edit the Response Spectra Library	

























Appendix A – RISA-2D Toolbar Button Quick Reference

	Rebar Layout  Create and edit a custom rebar layout	Create and edit a rebar layout
	Template  Perform High Level Generation Operations	Perform high level generation operations
	New Model View  Create a new model view	Create a new model view (CTRL+F2)
	Open Spreadsheets  Select spreadsheets to open	Select spreadsheets to open
	Refresh  Refresh all windows with current data	Refresh all open windows with the most current data
	Basic Load Case  Open the basic load case spreadsheet	Basic Load Case (BLC) spreadsheet
	Load Combinations  Open the load combinations spreadsheet	Load Combinations spreadsheet
	Solve  Perform the analysis and design calculations	Perform the analysis and design calculations (F7)
	Browse Results  Select results to browse	Select results to browse
	Erase Results  Erase all solution results	Erase all solution results
	Data Entry toolbar  Turn the spreadsheet shortcuts menu on or off	Turn the spreadsheet shortcuts window off or on
	Results toolbar  Turn the results shortcuts menu on or off	Turn the results shortcuts window off or on
	Help  View Help topics	View help topics (CTRL+F1)
	Tiling	Tile window options















Window Toolbar

...in Model View



Button	Title	Label in RISA-2D	Shortcut
	Model Display Options 	Display Model Display Options	(F2)
	Rotate buttons 	Rotate the view counter-clockwise about the X axis	
		Rotate the view clockwise about the X axis	
		Rotate the view counter-clockwise about the Y axis	
		Rotate the view clockwise about the Y axis	
		Rotate the view counter-clockwise about the Z axis	
		Rotate the view clockwise about the Z axis	
View buttons			
			
	Isometric  Display an isometric view	Snap to an Isometric view	
	XY Planar  Display an XY planar view	Snap to an XY planar view	
	XZ Planar  Display an XZ planar view	Snap to an XZ planar view	
	YZ Planar  Display a YZ planar view	Snap to an YZ planar view	
Zoom buttons			
			
	Zoom In 	Zoom IN (closer view) on the model (+)	PLUS (+)
	Zoom Out 	Zoom OUT (view farther away) on the model (-)	MINUS (-)
	Box Zoom 	Draw a box around the part of the model to be zoomed	

























Appendix A – RISA-2D Toolbar Button Quick Reference

	Redraw  Redraw full model view	Redraw full model view
	Graphic Editing  Activate the Graphic Editing toolbar (also known as Drawing toolbar)	Activate the Graphic Editing (Drawing) toolbar (CTRL +G)
	Save or Recall View  Save or recall view states	Save or recall view states
	Clone View  Make an exact copy of current model view	Clone (make an exact copy of) the current model view
Loads Display buttons		
		
	Display Loads  Toggle display of the loads	Toggle display of the loads (LC or CAT)
	Loads List – lists the available loads 	Select your load display from this list
	Switch Loads  Switch loads display	Switch load display
	Rendering  Toggle between wireframe and rendering of beams and plates	Toggle between wireframe and rendering of beams and plates
	Joint Labels  Joint labels toggle	Toggle the joint labels
	Member Labels  Member labels toggle	Toggle the member labels
	I End-J End  Toggle display of member I end, J end representation	Toggle display of member I End, J ends
	Boundary Conditions  Toggle display of the boundary conditions	Toggle display of the boundary conditions
	Global Axes  Toggle the global axes icon	Toggle the global axes icon

Window Toolbar









...in Spreadsheet View



Button	Title	Label in RISA-2D	Shortcut
	New Line  Insert a new line before the current line	Insert a new line before the current line	(F3)
	Delete Line  Delete the current line	Delete the current line	(F4)
	Repeat Line  Repeat the current line	Repeat the current line	(F8)
	Fill  Fill the currently marked block	Fill the currently marked block of cells	(CTRL+F)
	Math  Perform math on the currently marked block	Perform math on the currently marked block	(CTRL+M)
	Mark Lines  Mark all the lines	Mark all the selected lines	
	Delete Lines  Delete the currently marked lines	Delete the currently marked lines	(CTRL+D)
	Unmark Lines  Unmark all the lines	UNmark all the lines	(CTRL+L)
	Select Marked Lines  Select all marked lines	Select all marked lines	
	Unselect Marked Lines  Unselect all marked lines	Unselect all marked lines	
	Paste  Paste from the clipboard	Paste from the clipboard	(CTRL+V)
	Help  Help on the current window	Help for the current window	(SHIFT+F1)

Appendix A – RISA-2D Toolbar Button Quick Reference

These additional buttons appear after results are generated:

















	Replace and Resolve  Replace current shapes and then solve again	(Only available while in the Suggested Shapes spreadsheet) Replace current shapes and then re-solves	
	Exclude After  Exclude all results after the current item	(Available in most Results spreadsheets) Exclude all results after the current item	
	Unexclude  Un-Exclude all previously excluded results	(Available in most Results spreadsheets) Un-exclude all previously excluded results	
	Sort  Sort based on the values in the current column	(Available in most Results spreadsheets) Sort based on the values in the current column	F9

Drawing Toolbar







































Button	Title	Label in RISA-2D	Shortcut
	Draw New Members 	Draw new members	
	Draw New Plates 	Draw new plates	
	Draw New Wall Panels 	Draw new wall panels	
	Modify Boundary Conditions 	Modify boundary conditions	
	Joint Loads or Moments  Apply joint loads or moments to joints	Apply joint loads or moments to joints	
	Distributed Loads  Apply distributed loads to members	Apply distributed loads to members	
	Point Loads or Moments  Apply point loads or moments to members	Apply point loads or moments to members	
	Moving Point Loads  Apply moving point load to member	Apply moving point load to member	
	Linear Translation Move  Move via linear translation the currently selected part	Move via linear translation the currently selected part of the model	
	Rotational Move  Move via rotation the currently selected part	Move via rotation the currently selected part of the model	
	Scale Factor Move  Move via a scaling factor the locations for the currently selected joints.	Move via a scaling factor the locations for the currently selected joints	
	Linear Offset Copy  Copy the currently selected part using linear offsets	Make copies of the currently selected part of the model using linear offsets	
	Rotational Offset Copy  Copy the currently selected part using rotational offset	Make copies of the currently selected part of the model using rotational offset	

Appendix A – RISA-2D Toolbar Button Quick Reference

	Mirror Image Copy  Mirror image copy of the selected part	Make a mirror image copy of the currently selected part of the model
	Model Merge  Perform a model merge on all or part of the model	Perform a model merge on all or part of the model
	Trim  Trim the member	Trim the member
	Extend  Extend the member	Extend the member
	Delete  Delete parts of the model	Delete parts of the model
	Modify Drawing Grid  Modify the drawing grid and snap points	Modify the drawing grid and snap points
	Drawing Grid  Toggle the drawing grid on or off	Toggle the drawing grid on or off
	Universal Snap Points  Toggle the universal snap points on or off	Toggle the universal snap points on or off

Selection Toolbar

	Button	Title	Label in RISA-2D	Shortcut
		Select All  Select the entire model	Make the entire model selected	CTRL+A
		Box Select  Draw a box around the part to be selected	Draw a box around the part of the model to be selected	
		Polygon Select  Draw a polygon around the part to be selected (double click to end)	Draw a polygon around the part to be selected (double click to end)	
		Line Select  Draw a line through the beams and plates to be selected	Draw a line through the beams and plates to be selected	
		Unselect All  Unselect the entire model	Make the entire model UNselected	CTRL+U
		Box Unselect  Draw a box around the part to be unselected	Draw a box around the part of the model to be UNselected	
		Polygon Unselect  Draw a polygon around the part to be unselected (double click to end)	Draw a polygon around the part to be UNselected (double click to end)	
		Line Unselect  Draw a line through the beams and plates to be unselected	Draw a line through the beams and plates to be UNselected	
		Invert Selected  Invert the selected areas of the model	Invert the selected state of the model	CTRL+I
		Criteria Selection  Select or unselect	Select or Unselect based on other criteria	
		Save/Recall Selection  Save or recall selections of the model	Save or Recall Selection States for the Model	
		Lock Unselected Lock the unselected parts of the model	Lock the unselected part of the model	CTRL+L