

RISASection

Rapid Interactive Structural Analysis - Sectional Property Calculator

Version 2.1 - General Reference



26632 Towne Centre Drive, Suite 210
Foothill Ranch, California 92610

(949) 951-5815
(949) 951-5848 (FAX)

www.risa.com

Copyright © 2018, RISA Tech, Inc. All rights reserved. RISA is part of the [Nemetschek Group](#).

RISA, the RISA logo and RISASection are registered trademarks of RISA Tech, Inc. All other trademarks mentioned in this publication are the property of their respective owners.

No part of this publication may be reproduced or transmitted in any form or by any means, electronic or mechanical, including photocopying, recording, or otherwise, without the prior written permission of RISA Tech, Inc.

Every effort has been made to make this publication as complete and accurate as possible, but no warranty of fitness is implied. The concepts, methods, and examples presented in this publication are for illustrative and educational purposes only, and are not intended to be exhaustive or to apply to any particular engineering problem or design. The advice and strategies contained herein may not be suitable for your situation. You should consult with a professional where appropriate. RISA Tech, Inc. assumes no liability or responsibility to any person or company for direct or indirect damages resulting from the use of any information contained herein.

Table of Contents

Before You Begin	1		
Minimum System Requirements	1		
License Agreement	1		
Technical Support	3		
Application Interface	4		
Title Bar	4		
Menus	4		
Hot Keys	6		
Toolbars	6		
Database	9		
Status Bar	9		
Shape Library	10		
Workspace	10		
Rendered View	11		
Section Information	11		
Properties Window	12		
Building Sections	13		
How it Works	13		
Some Basic Terms and Notations	13		
Basic Steps	13		
Selecting Shapes	14		
Moving and Editing Shapes	15		
Shape Editor	16		
Shape Layout Editor	17		
Solving for Properties	19		
Saving Section Files	19		
Property Calculations	20		
Important Assumption!	20		
Calculation Methodology	21		
Section Properties	22		
Assumptions and Limitations	24		
Editable Properties	30		
Integration with RISA-3D, RISA-2D, and RISAFloor	33		
		Interaction with RISA-3D, RISA-2D, and RISAFloor	33
		Troubleshooting Integration	34
		DXF Import	37
		DXF Import Procedure	37
		Import DXF Options	37
		Invalid DXF Shapes	38
		Options	39
		General Options	39
		View Options	41
		Section Property Options	42
		Printing	43
		Preparing Report and Printing	43
		Examples	45
		Built-Up Shapes Examples	45
		Multi-Material Shapes Examples	52
		Technical Support	61

Before You Begin

RISASection is a general-purpose built-up section properties calculator program. This program has been developed to make the definition and calculation of built up sections as fast and easy as possible.

The sections that you create will be made up of individual basic shapes. You may double-click or drag-and-drop these shapes from the shape library onto the workspace where you build the overall section. You may then use the drawing grid to reposition and resize the basic shapes to achieve the desired cross section. Alternatively, you may import a more complicated shape directly from your DXF file and then build upon it, or use it to import into RISA-2D, RISA-3D, or RISAFloor for design in your analysis model.

The properties of the section may be continuously updated as you edit and refine your section. Once you are satisfied with your section, you may build a report for printing.

Minimum System Requirements

One of the following operating systems is required:

- Microsoft Windows 10 (64 bit only)
- Microsoft Windows 8.1 (64 bit only)
- Microsoft Windows 7 SP1 (64 bit only)

One of the following hardware is required:

- 1 GHz or faster processor (x86 or x86-64)
- 1024x768 or higher monitor resolution
- 2 (or more) button mouse
- 1 GB of RAM
- 4 GB of hard disk space

Note

- The amount of space needed by RISASection to solve a particular structural model depends on the size of the file. RISASection has been written such that it will use as much RAM as is available. If this isn't enough, RISASection will start using hard drive space until enough memory is obtained to solve the problem. Of course, if RISASection is required to use hard drive space, the solution will be much slower. So, the more memory you have available, the better.

License Agreement

END-USER LICENSE AGREEMENT FOR RISA TECH, INC. SOFTWARE

The RISASection software product (SOFTWARE PRODUCT) includes computer software, the associated media, any printed materials, and any electronic documentation. By installing, copying, accessing or otherwise using the SOFTWARE PRODUCT, you agree to be bound by the terms of this agreement. If you do not agree with the terms of this agreement RISA Tech, Inc. is unwilling to license the SOFTWARE PRODUCT to you. In such event, you must delete any installations and destroy any copies of the SOFTWARE PRODUCT and return the SOFTWARE PRODUCT to RISA Tech, Inc. within 60 days of purchase for a full refund.

Copyright © 2018 by RISA Tech, Inc. All rights reserved. RISA is part of the [Nemetschek Group](#). The SOFTWARE PRODUCT is protected by United States copyright laws and various international treaties. All rights not specifically granted under this agreement are reserved by RISA Tech, Inc. "RISA" as applied to structural engineering software is a registered trademark of RISA Tech, Inc.

1. **SOFTWARE LICENSE.** The SOFTWARE PRODUCT is licensed, not sold. All right, title and interest is and remains vested in RISA Tech, Inc. You may not rent, lease, or lend the SOFTWARE PRODUCT. You are specifically granted a license to the use of this program on no more than one CPU at any given time. The Network Version of the SOFTWARE PRODUCT is licensed for simultaneous use on a certain maximum number of network stations that varies on a per license basis. The Subscription Version of the SOFTWARE PRODUCT is licensed for simultaneous use on a certain maximum number of CPU's that varies on a per license basis. As part of the license to use the SOFTWARE PRODUCT, the program user acknowledges the reading, understanding and acceptance of all terms of this agreement. The SOFTWARE PRODUCT may not be reviewed, compared or evaluated in any manner in any publication without expressed written consent of RISA Tech, Inc. You may not disassemble, decompile, reverse engineer or modify in any way the SOFTWARE PRODUCT. If the SOFTWARE PRODUCT was purchased at a discounted price for educational purposes it may in no event be used for professional design purposes. The terms of this license agreement are binding in perpetuity.

2. **DISCLAIMER.** We intend that the information contained in the SOFTWARE PRODUCT be accurate and reliable, but it is entirely the responsibility of the program user to verify the accuracy and applicability of any results obtained from the SOFTWARE PRODUCT. The SOFTWARE PRODUCT is intended for use by professional engineers and architects who possess an understanding of structural mechanics. In no event will RISA Tech, Inc. or its officers be liable to anyone for any damages, including any lost profits, lost savings or lost data. In no event will RISA Tech, Inc. or its officers be liable for incidental, special, punitive or consequential damages or professional malpractice arising out of or in connection with the usage of the SOFTWARE PRODUCT, even if RISA Tech, Inc. or its officers have been advised of or should be aware of the possibility of such damages. RISA Tech, Inc.'s entire liability shall be limited to the purchase price or subscription price of the SOFTWARE PRODUCT.

3. **LIMITED WARRANTY.** RISA Tech, Inc. warrants that the SOFTWARE PRODUCT will operate but does not warrant that the SOFTWARE PRODUCT will operate error free or without interruption. RISA Tech, Inc.'s sole obligation and your exclusive remedy under this warranty will be to receive software support from RISA Tech, Inc. via telephone, email or fax. RISA Tech, Inc. shall only be obligated to provide support for the most recent version of the SOFTWARE PRODUCT. If your version of the SOFTWARE PRODUCT is not the most recent version RISA Tech, Inc. shall have no obligation to provide support in any form. Except as stated above the SOFTWARE PRODUCT is provided without warranty, express or implied, including without limitation the implied warranties of merchantability and fitness for a particular purpose.

4. **PROTECTION DEVICE.** In the event the SOFTWARE PRODUCT requires the use of a PROTECTION DEVICE to operate, you are specifically prohibited from attempting to bypass the functionality of the PROTECTION DEVICE by any means. A lost or stolen PROTECTION DEVICE will not be replaced by RISA Tech, Inc.

5. **SUBSCRIPTION SERVICE.** In the event the SOFTWARE PRODUCT is accessed via a SUBSCRIPTION SERVICE, RISA Tech, Inc. shall make the SUBSCRIPTION SERVICE available for your use via an internet connection for the Term of the Subscription Agreement. At the end of the Term of the Subscription Agreement your right to access the SOFTWARE PRODUCT via the SUBSCRIPTION SERVICE will terminate unless the Subscription Agreement is renewed. RISA Tech, Inc. does not guarantee the SUBSCRIPTION SERVICE will be available error-free or uninterrupted. You acknowledge RISA Tech, Inc. does not control the transfer of information over the internet and that the SUBSCRIPTION SERVICE may be subject to interruptions or delays beyond the control of RISA Tech, Inc. RISA Tech, Inc. is not responsible for any delivery failures or any other damages resulting from any problems with the SUBSCRIPTION SERVICE.

6. **TERMINATION.** RISA Tech, Inc. may terminate your right to use the SOFTWARE PRODUCT if you fail to comply with the terms and conditions of this agreement. In such event, you must delete any installations and destroy any copies of the SOFTWARE PRODUCT and promptly return the SOFTWARE PRODUCT to RISA Tech, Inc.

7. **CHOICE OF LAW.** By entering into this Agreement in accordance with Paragraph 1, above, you have agreed to the exclusive jurisdiction of the State and Federal courts of Orange County, California, USA for resolution of any dispute you have relating to the SOFTWARE PRODUCT or related goods and services provided by RISA Tech, Inc. All disputes therefore shall be resolved in accordance with the laws of the State of California, USA and all parties to this Agreement expressly agree to exclusive jurisdiction of, and venue in, the courts in Orange County, California, USA. No choice of law rules of any jurisdiction apply.

8. **PRIVACY POLICY.** All information you provide and have provided, or which we otherwise collect and have collected, through or in connection with the SOFTWARE PRODUCT, including personally identifiable information about you, is subject to, and will be treated in accordance with, the then-current Privacy Policy located at <http://risa.com/privacy>, which is incorporated herein by this reference. By accessing, downloading, installing, using and providing information to or through the SOFTWARE PRODUCT, you consent to all actions taken by us with respect to such information in compliance with the Privacy Policy.

Technical Support

Complete program support is available to registered owners of RISASection and is included in the purchase price. This support is provided for the life of the program. The "life of the program" is defined as the time period for which that version of the program is the current version. In other words, whenever a new version of RISASection is released, the life of the previous version is considered to be ended. Technical support is a limited resource; first priority will always be given to those clients who are current.

See [Technical Support](#) for a list of your support options.

Application Interface

Modeling features in RISASection may be accessed through the main menu, shortcut menus, toolbars, and shortcut keystrokes. You may use any or all of these vehicles to interact with the software. The main menu has the advantage of containing all of the program options and features and may initially be the simplest to use, letting you learn just one system. The toolbars contain more common options and invoke with one click. The shortcut menus present options relevant to the task at hand. The shortcut keys provide a fast way to access features should you use the program often enough to make them familiar to you. All of these features are discussed in the sections below. There are many ways to access features and the method that you will use will simply be a matter of personal preference. The good news is that you have the options.

Title Bar

The bar along the top of the screen is called the title bar, which displays the name of the file that is currently open. The three buttons  on the far right side of the title bar are used to control the main window. The left button will shrink the main application window to a button on the task bar. The middle button will shrink or maximize the window on your screen. The right button will close the window, prompting you to save changes if necessary. You will also see these buttons in other windows and they have the same functions there as well.

The actual work that you do will be in the main area on the screen, which is called the workspace. When you open a model view, spreadsheet, or a dialog, it will be opened in the workspace and listed in the **Window** menu. You may have as many windows open as you like.

Menus

Main Menu

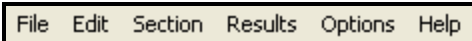

All of the program features may be accessed through the main menu toolbar at the top of the screen.

File Menu

New Section File will close the current file, prompting for saving if necessary, and will open a new file.

Open Section File will close the current file, prompting for saving if necessary, and will open an existing file.

Save Section File will save the current file, prompting for a name if necessary.

Save Section File As... will save the current file, prompting for a name.

Import DXF File will prompt the user to select the DXF file to import.

Export will allow the user to save the file as a Legacy.nms (old file format) file.

Project Information will allow you to enter information such as project name, job number, company name, designer name, and any additional remarks. It will put this information as a header on the pages of your reports.

Print Current Section will access RISASection printing options.

Page Setup... will access RISASection printing options.

Exit will close RISASection, prompting for saving if necessary.

Edit Menu

Undo will undo the last edit that was applied to the model, whether it was made graphically or in the spreadsheets. You may continue to apply Undo to remove up to 100 model edits.

Redo will reverse the last undo that was applied to the model. You may continue to apply Redo to remove up to 100 undo operations.

Cut will remove the selected spreadsheet cells or model view from the active window, but it will copy (see below) them to the clipboard so you can paste them elsewhere.

Copy will copy the selected spreadsheet cells or model view from the active window to the clipboard.

Paste will paste data from the clipboard to the spreadsheet cells.

Select All will select the entire model.

Delete Selected Shapes will delete the selected portion of the model.

Section Menu

Add New Section to File creates a new (blank) section in the file.

Rename Section prompts for a new name of the current section.

Remove Section from File deletes the current section from the file.

Shape Layout lets you view and edit the labels, positions, and multipliers for each individual shape in the section.

Edit Current Shape lets you view and edit the labels, dimensions, and the modulus of elasticity of the currently selected shape in the workspace.

Show Dimensions toggles the dimensions in the workspace on and off.

Rotate and Flip provides tools to move selected shapes relative to their local axes.

Align and Stack provides tools to move selected shapes relative to other selected shapes.

Merge Shapes lets you merge together individual shapes into one section. This can ensure that you get an appropriate calculation of Torsional J.

Explode Shapes lets you explode a previously merged section back to the original individual shapes.

Add to Report adds the current view of the section to your report.

Results Menu

Compute General Properties computes all properties except for the torsional constant J.

Compute Torsional Constant J computes the torsional constant J.

Report Creation Wizard builds reports for printing.

Preview Current Report shows the current report on the screen.

Print Current Report prints the current report, which consists of all of the sections in the file and anything else that you have manually added to the report.

Print Current Section prints the properties, basic properties and diagram of the current section.

Options Menu

General Options... provides options for units and file locations.

View Options... provides for color choices as well as automatic refresh or recalculation.

Section Property Options... provides options for calculation of transformed section properties.

Help Menu

Contents opens the help file so that you may search the contents and the index.

Send Email to RISA initiates an e-mail to RISA.

Go to RISA Web Site opens the default Internet browser to the RISA website.

About RISASection provides version and serial number information.

Shortcut Menu

Undo	Ctrl+Z
Redo	Ctrl+Y
Cut	Ctrl+X
Copy	Ctrl+C
Paste	Ctrl+V
Select All	Ctrl+A
Delete Selected Shapes	Del

The shortcut menu is also referred to as the **Right-Click** menu. This is because to access the shortcut menu you simply click the RIGHT mouse button where you are working to see options that are relevant to what you are doing. For example if you right click in the workspace a menu will pop up and provide options to help you modify the section.

Perhaps the most important feature of this menu is that it is located wherever you RIGHT click the mouse. This way you do not need to move away from where you are working to select the features you want to use.

Hot Keys























Hot Keys allow you to use the keyboard to quickly access the following features:

Key Combination	Function
CTRL + N	New Section File
CTRL + O	Open Section File
CTRL + S	Save Section File
CTRL + P	Print Current Section
CTRL + Z	Undo
CTRL + Y	Redo
CTRL + X	Cut
CTRL + C	Copy
CTRL + V	Paste
CTRL + A	Select All
F7	Calculate General Properties
F8	Calculate Torsional J
F1	Access Help Menu Contents



Toolbars























The available toolbar buttons are listed below. There are equivalent menu options available for almost all toolbar buttons. The options have been grouped into two toolbars (the RISA toolbar and the Window toolbar) from the point of view of common and specific usage. The Window toolbar will affect only the current section in the workspace, but the buttons on the RISA toolbar can be used for tasks common to all views, properties, windows, etc.



RISA Toolbar

	New	Creates a new Section file.
	Open	Opens an existing Section file.
	Save	Saves the current Section file.
	Print Current	Prints the current Section report.
	Add Section	Adds a new Section to the current file.
	Rename Section	Allows renaming of a Section.
	Remove Section	Removes selected Section from file.
	Cut	The selected Shapes in the workspace will be cut by pressing this button and then placed in the Clipboard.
	Copy	The selected Shapes in the workspace are copied to the Clipboard. These copied Shapes can be pasted using the Paste button.
	Paste	The Shapes placed in the Clipboard using Copy button or Cut button will be pasted in the workspace.
	Delete	Deletes the selected part of the Section.
	Undo	Undo previous action. This can be used to undo multiple previous actions.
	Redo	Redo the previous Undo. This can be used to redo multiple previous actions.
	Section Props	Computes basic properties of the Section.
	Torsion Props	Computes the Torsional Constant (J) of the Section.
	Report Wizard	Opens the Report Creation Wizard.
	Preview	Allows you to preview the current report.
	Print Report	Prints the current report for all of the Sections in the file.
	Help	Opens the Help menu.
	E-mail	Opens an E-mail to RISA. An Internet connection is needed for this option.
	Web Site	Opens the RISA web site. An Internet connection is needed for this option.
	About	Reports program info such as version number and copyright date.





Window Toolbar

	Edit Layout	Opens Edit Shape Layout to locate the shapes by specifying coordinates and angles.
	Shape Editor	Opens the Shape Editor Form for the current shape. The Shape Editor is used to modify the dimensions and properties of the current shape.



	Toggle Dims	Toggles the display of overall dimensions of the Section in the Main Drawing Area.
	Rotate Group	This command will rotate the selected group of Shapes by the amount you specify.
	Rotate Right	Rotates the selected Shape by 90 degrees in the clockwise direction.
	Rotate Left	Rotates the selected Shape by 90 degrees in the counter-clockwise direction.
	Flip Horizontal	Flips the selected shape about a vertical axis.
	Flip Vertical	Flips the selected shape about a horizontal axis.
	Align Left	Aligns the selected Shapes on their left edge. The alignment is done with respect to the least value of the x-coordinate of the first selected shape.
	Align Center	Aligns the selected Shapes along the vertical centerline. The alignment is done with respect to the x-centroid of the first selected shape.
	Align Right	Aligns the selected Shapes on their right edge. The alignment is done with respect to the highest value of the x-coordinate of the first selected shape.
	Align Top	Aligns the selected Shapes on their top edge. The alignment is done with respect to maximum value of the y-coordinate of first selected shape.
	Align Middle	Aligns the selected Shapes along the horizontal centerline. The alignment is done with respect to the y-centroid of first selected shape.
	Align Bottom	Aligns the selected Shapes along bottom edge. The alignment is done with respect to the lowest value of the y-coordinate of the first selected shape.
	Stack Vertically	Stacks the selected Shape vertically, one on top of the other. The x-coordinates are not changed.
	Stack Horizontally	Stacks the selected Shape horizontally, side-by-side. The y-coordinates are not changed.
	Parallel Align	Allows you to select a line in the currently selected shape and align it to another (parallel) line of a different shape.
	Merge Shapes	This will merge together all your individual shapes into one section.
	Explode Shapes	This will explode previously merged shapes back to the original individual shapes.
	Reset View	Resets the view. This will reset the view in such a way that the whole Section is visible with all shapes on the workspace.
	Zoom In	This button will enlarge the view and you may then scroll using the horizontal and vertical scroll bars to any required view.
	Zoom Out	This button will zoom out to see more of the section in the view.
	Show/Hide Grid	Show/Hide the grid lines. This may be used to hide grid lines for a clear view of the Shapes and the Sections in the workspace.
	Modify Grids	Opens the paper grid size dialog which allows you to modify grid size and spacing.

	Snap to Grid	Toggles the Snap to Grid option. If Snap to Grid is activated then all movements of the mouse are locked to the nearest grid. This includes drawing of shapes, moving shapes or resizing the shapes. For more precise control, you may modify the grid sizes, switch off the Snap to Grid option or use Shape Layout Editor.
	Add Current View	Add the current view to the Main Report.

Rendered View Window Toolbar

	Activate 3D View	Switches from a section view to a rotating isometric three dimensional view.
	Reset 3D View	Resets the view. This will reset the view in such a way that the whole Section is visible with all shapes on the workspace.
	Zoom In	This button will enlarge the view and you may then scroll using the horizontal and vertical scroll bars to any required view.
	Zoom Out	This button will zoom out to see more of the section in the view.
	Add Current View	Add the current view to the Main Report.

Properties Window Toolbar

	Copy	The selected properties are copied to the Clipboard. These copied property values can then be pasted using the Paste button.
	Add Current View	Add the current view to the Main Report.

Database

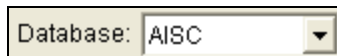

At the far right side of the RISA Toolbar is the **Database** selection menu. This menu is only available if you have selected the **RISA HR Database** tab from the [Shape Library](#). The Database menu controls which Hot Rolled Steel shape database (AISC, Canadian, Euro Shapes, etc.) is displayed in the RISA HR Database menu on the Shape Library.

Status Bar

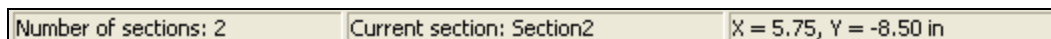

The status bar passes useful information to you as you work. It is divided into three parts located along the bottom of the main application window, just beneath the workspace.

1. The first box gives the number of sections that are in the file. Note that you can create multiple sections and save them within a single file.
2. The second box gives the name of the shape that is currently shown in the workspace.
3. The last box on the status bar indicates the coordinates where the cursor is currently located.

Shape Library

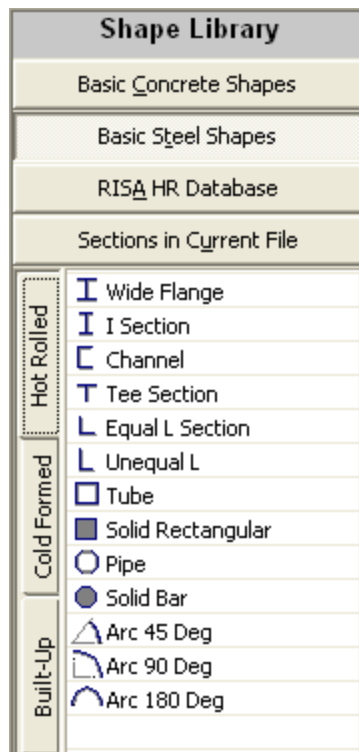

The shape library provides basic shapes that are used for building sections. Located on the left side of the application, the library is divided into four categories: Basic Concrete Shapes, Basic Steel Shapes, RISA HR Database, and Sections in Current File.

Basic Concrete Shapes: This tab contains concrete sections with different geometric shapes. These shapes may be modified by editing the dimensions in the shape editor or by simply resizing with the mouse. The resizing with mouse will modify the overall dimension of the section and proportionally change the component dimensions.

Basic Steel Shapes: This tab contains general steel shapes that can be modified in the same way that Basic Concrete Shapes can be. It has been further subdivided with vertical tabs on the left into the following three groups: hot rolled shapes, cold formed shapes and built-up shapes.

RISA HR Database: This tab contains a database of Hot Rolled Steel members that is taken from the designated [Database](#). These shapes can not be manipulated.



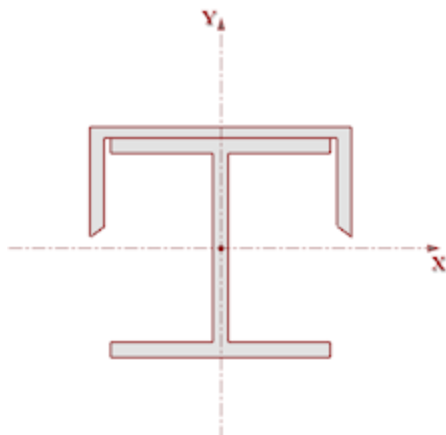

Sections in Current File: This tab contains the current sections that the user has created in this file. Note that you can create multiple sections within one file. You need to be careful with naming of your sections. See [Section File Names](#) and [Toolbars](#) to get more information on this.



Workspace



The workspace is the main (center) portion of the application where you actually build and edit your section. To do this, drag basic shapes from the libraries on the left and then resize and reposition those shapes to define the section. The main axes help to place shapes graphically. The shape editor assists you with the basic dimensioning of the basic shapes that you add to the section from the libraries. The layout editor gives exact coordinates and orientation for each shape for fine adjustments. The layout grid with snapping, dimensions and layout tools may be used to help you position shapes.

Workspace Options

- **Grid Toggle:** The workspace grid may be turned on and off by clicking the  button on the Window Toolbar.
- **Grid Increments:** Click  to edit the grid increments.
- **Grid Snapping:** Grid snapping may be turned on and off by clicking . When snapping is turned on the movement and resizing of shapes is restricted to the nearest grid lines.
- **Dimension Toggle:** Overall dimensions of the section may be turned on and off by clicking .

- **Zoom:** Use  and  to zoom the view of the workspace in and out.
- **Reset View:** Click  to reset to a full view.
- **Color Options:** The colors used in the workspace may be adjusted in the **View Options...** under the **Options** menu.

Rendered View

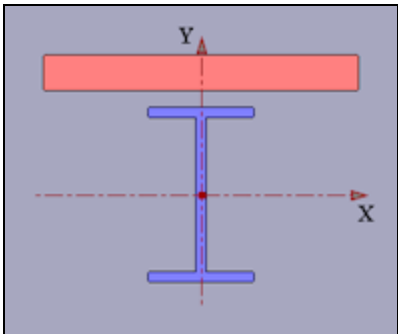

The rendered view is the upper right window that shows the rendered (solid) form of the section created in the workspace. This view has its own toolbar. The colors used in the rendering may be adjusted in the **Options** menu.

Shapes are filled with appropriate color. The void in a pre-defined shape and in any shape assigned a negative shape multiplier is drawn in the background (or shown in opaque color in the rendered view).

By default, different colors are used to draw and fill shapes of different material or type. Separate colors are used for Concrete, Hot Rolled and Cold Formed shapes. To change the colors used in drawing these shapes, select **View Options** from the **Options** menu. You can specify the border and fill colors for various types of shapes as shown here.

Section Information

Just beneath the rendered view is the **Section Information** window. This window displays the basic information of the selected section.

Section Information	
File Name:	Built Up Column.nmsx
Section Name:	Section1
Material Type:	Hot Rolled Steel
Shape Type:	Tapered WF

This information includes:

File Name - This is the name of the RISASection file (.nmsx file). It cannot be edited from this window; if you'd like to re-save the file with a different name please select **Save Section File As** from the [File](#) menu.

Section Name - This is the name of the current Section. Since each RISASection file (.nmsx file) can contain multiple Sections, this entry allows you to name them individually.

Material Type - This selection allows you the ability to assign a Material Type to your section in order to then select an appropriate Shape Type (please see below). This information is only used for integration with RISA-3D and RISAFloor and will *not* effect the Property Multiplier information. Currently the only options are General and Hot Rolled Steel. More Material Type options will be added to a future version of RISASection.

Shape Type - Depending on your Material Type selection (please see above), this menu changes to offer you material specific shape types. This information is used in the integration with RISA-3D and controls which sections of the code are used to perform code check calculations. Currently the only options are General (Arbitrary)

and Hot Rolled Steel (Wide Flange, Channel, Tube, etc.) material shape types. More material and shape type options will be added to a future version of RISASection.

Properties Window

The **Properties** window is located at the lower right portion of the screen. It shows the summary of the geometric properties of the current Section (the one displayed in the [Workspace](#)).

This window displays all of the calculated cross sectional shape properties for the current Section. These entries change depending on the **Material** and **Shape Type** selected in the [Section Information](#) window. Please see the [Section Properties topic](#) for more information on the individual properties.

Auto	Properties		
	Total Width =	10.000	in
	Total Height =	20.000	in
	Centroid, Xo =	-0.000	in
	Centroid, Yo =	-0.000	in
	X-Bar (Right) =	6.974	in
	X-Bar (Left) =	3.026	in
	Y-Bar (Top) =	10.000	in
	Y-Bar (Bot) =	10.000	in
	Area, Ax =	42.667	in ²
	Inertia, Ixx =	2650.07	in ⁴
	Inertia, Iyy =	379.30	in ⁴
	Inertia, Ixy =	0.000	in ⁴
	Sx (Top) =	265.01	in ³
	Sx (Bot) =	265.01	in ³
	Sy (Left) =	125.35	in ³
	Sy (Right) =	54.389	in ³
	rx =	7.881	in
	ry =	2.982	in
	Plastic Zx =	311.85	in ³
	Plastic Zy =	105.78	in ³
<input checked="" type="checkbox"/>	Flange Thick =	1.212	in
<input checked="" type="checkbox"/>	Web Thick =	1.000	in
	Shear Center, Xs =	-6.343	in
	Shear Center, Ys =	0.000	in
	ro =	10.894	in
<input checked="" type="checkbox"/>	Torsional J =	19.959	in ⁴
	Cw =	2.522E+004	in ⁶
	eo =	3.234	in

Important Note:

The values above the solid black line are calculated per the actual geometry in the workspace. The values below the line (except Torsional J) are [approximate](#) values based on the Flange Thick, Web Thick, Leg Thick values. Since RISASection cannot guarantee the calculation of these Thickness values, you can edit these and see how they change the other torsional properties which are calculated using approximate formulas.

The only exception to this is the Torsional J value. Torsional J is always calculated using a finite element solution of the actual geometry in the workspace. However, you can always [edit](#) this value if you choose.

Building Sections

How it Works

The sections that you create will be made up of basic shapes. You may double-click or drag-and-drop these shapes from the shape library to the workspace where you build the overall section. Working on the optional drawing grid you may reposition and resize the basic shapes to achieve the desired cross section.







The properties of the section may be continuously updated as you edit and refine your section. Once you have completed the section you may build a report for printing or save the file for future use in RISASection or for importing by RISA-2D, RISA-3D, and RISAFloor.

Some Basic Terms and Notations

- A *Shape* is the basic component that can be used to create *Sections*. The properties of an individual Shape can be determined and its dimensions can be modified. New Shapes can be created and predefined Shapes from standard libraries can also be used and modified.
- A [Shape Library](#) is an area on the program interface where standard Shapes can be obtained.
- A Section is a combination or collection of Shapes placed together to act as a single cross-section.
- A [Property Multiplier](#) is used to specify the relative weight of the Shape in the over all Section. Generally, it is the ratio of the Modulus of Elasticity of a particular shape and the **Base Modulus of Elasticity** (you can adjust this in the **Section Properties** tab of the **Options** menu). However, any positive, negative or zero value may be specified.

Basic Steps

To Build and Solve a Section

1. When you open the program, you are given a window that allows you to open an existing project, or, if you close the window, you can begin a project from scratch.
 - a. If you begin a project from scratch, you are ready to begin building your section. Remember, RISASection allows you to build multiple sections within a single file name. To add a new section to an existing file click  and click  to rename the section.
2. Select common shapes from the database of shapes in the [Shape Library](#) on the left side of the application. Double-click or drag-and-drop shapes from the libraries to the workspace.
3. If using generic shapes (from the "Basic" libraries) you may re-size the shapes in the Shape Editor once they are in the workspace by double-clicking the shape edge and entering the basic dimensions.
4. Reposition the shapes using the stacking and aligning tools or click  to use the [Shape Layout Editor](#).
5. Click  and  to calculate the properties if they aren't updating automatically.
6. Click  to print the current section or click  to build a report.

Notes:

- Alternatively you can import a shape from a DXF. Please see the [DXF Import](#) topic for more information on how to import these shapes.
- See the following sections to learn how to manipulate the shapes once you have added them to the section. It is important to give unique, descriptive names to each section so that you can discern them for use in RISA-2D, RISA-3D, and RISAFloor. Sections will be displayed by the Section name as well as the File name.

Selecting Shapes

After shapes have been added to the workspace from the library you may select one or more to move and edit in order to properly define the section.

Single Shapes

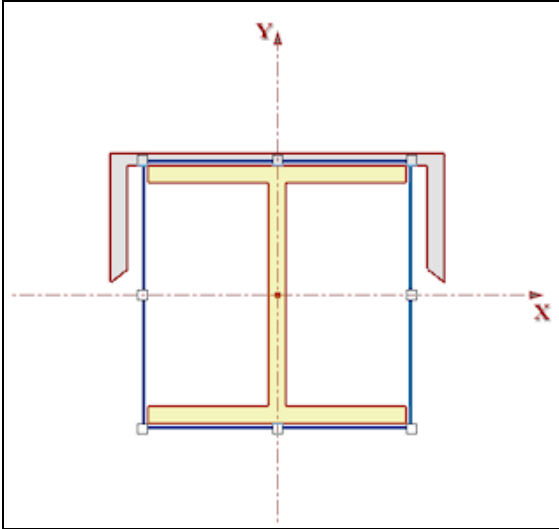

To select a single shape you may either click the edge of the shape or draw a box that contains only one entire shape (the box may contain part of another shape). The selected shape will be shown as above (outlined with a dashed line with sizing handles that may be used to stretch the shape).

Multiple Shapes

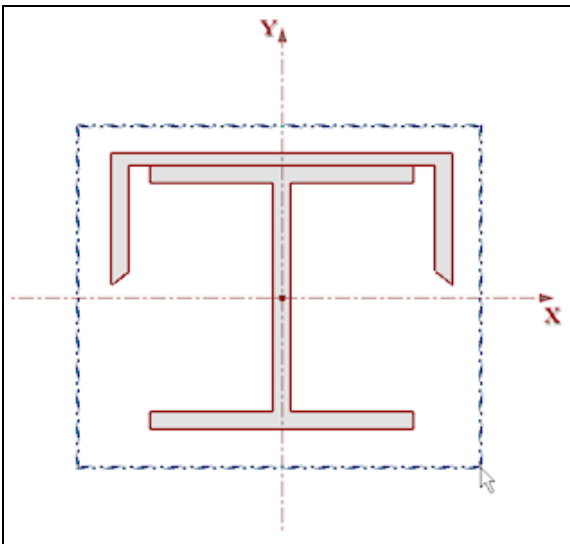

To select multiple shapes you may either hold down the shift key while clicking on the individual shapes, or draw a box that entirely contains the multiple shapes, as shown above. Shapes not entirely within the box will not be selected. The selected shapes will be shown outlined with a dashed line.

How to Use Shape Draw and Color Notation

All Shapes are drawn in true proportions on the screen as well as on the paper. The drawing area is automatically scaled to fit the Shapes. To create extra space around the Section or Shape drawing, you can use the zoom down button.

Closed Shapes are filled with appropriate color in the [Rendered](#) view. The open Shapes are drawn as single lines, irrespective of the actual thickness of the plate or sheet.

By default, different colors are used to draw and fill Shapes of different material or type. Separate colors are used for Concrete, Hot Rolled and Cold Formed Shapes. To change the colors used in drawing these Shapes, use the **View** tab in the **Options** menu. You can specify the border and fill colors for various types of Shapes. See [View Options](#) for more information.

Moving and Editing Shapes

There are a number of ways that you can edit the shapes after they are added from the Library to the Section. Some actions may be performed on multiple shapes simultaneously by first selecting the desired shapes. Snapping may also be used in conjunction with some of the methods to restrict stretching and moving to the nearest grid line. Grid snapping may be turned on and off by clicking .

Dragging Shapes

Dragging may be performed on individual shapes or selected multiple shapes by clicking and dragging the edge of a shape.

Note: This may be easier if you turn off the Snap to Grid option. Simply click the **Snap to Grid** button  to toggle this option on and off.

Stretching Shapes

Stretching (resizing) a single shape may be done by clicking the shapes edge to display resizing handles and then clicking and dragging the handles.

Note: You cannot stretch pre-defined shapes from one of the Hot Rolled Shape [Databases](#) or any [merged](#) shapes.

Rotating Shapes

The graphic editing rotate buttons are provided on the **RISA Toolbar**:



These buttons help you rotate and flip the selected shapes in the workspace.

Note: Because you can rotate a single shape, or a group of shapes, the rotate is always in reference to the centroid of the *selection rectangle*, not necessarily the centroid of the selected shape.

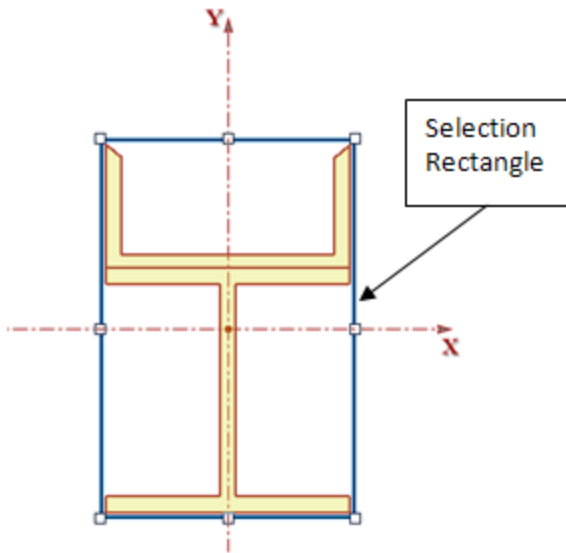

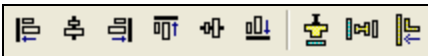

Aligning and Stacking Shapes

The graphic editing rotate buttons are provided on the **RISA Toolbar**:

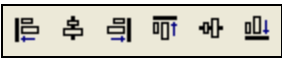



The **Alignment** buttons  help you align the sides or centers of selected shapes.

The **Stacking** buttons  help you stack selected shapes on top of one another or side-by-side.

The **Parallel Alignment** button  helps you align shapes per their parallel edges.



Merge and Explode

The general properties will automatically update to include all shapes in the section. However, you may want to merge the sections in order to get a more accurate Torsional J calculation. To do this, simply click the **Merge** button . If you want to un-merge the shapes, simply click the **Explode** button .

Note:

- Only shapes of the *same* material will merge.
- Shapes with a Property Multiplier of -1 (designating a void) will not merge.

Cutting and Pasting Shapes

You may cut and paste single or multiple shapes by selecting the shapes and then clicking cut , copy , or paste .

Shape Editor

The Shape Editor may be used to adjust the dimensions of a single shape.

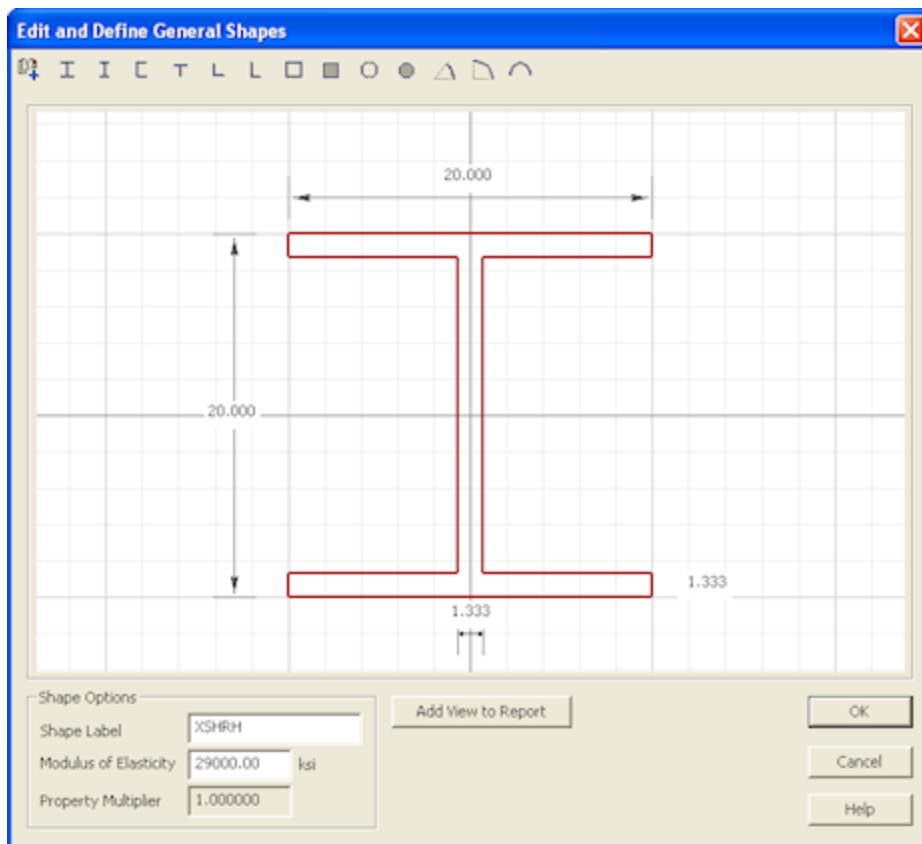

Double-click the edge of the shape or select the shape and click  to open the **Shape Editor**. This editor may be used to redefine the basic dimensions of the shape, shape label and modulus of elasticity.

The main part of the editor displays the shape and its dimensions. You can edit the dimensions by highlighting the values and specifying new dimensions. You can show the modified shape by pressing the **Refresh** button. You can also change the shape type by choosing from the toolbar on the top. The toolbar presents shapes from the same shape family such as **Basic Concrete Shapes** and **Basic Steel Shapes**.

You may also edit the Shape Label and Modulus of Elasticity. The Property Multiplier is a ratio between the input Modulus of Elasticity and the Modulus of Elasticity of Steel (29000 ksi).

Note

- You may not edit shapes in the RISA HR Databases. To specify custom shapes, choose the shape from the **Basic Steel Shapes** or **Basic Concrete Shapes** options in the [Shape Library](#) and edit the shape dimensions to define the custom size.

Shape Layout Editor

The Shape Layout Editor may be used to adjust the position of the individual shapes based on their centroid coordinates relative to the origin of the workspace.

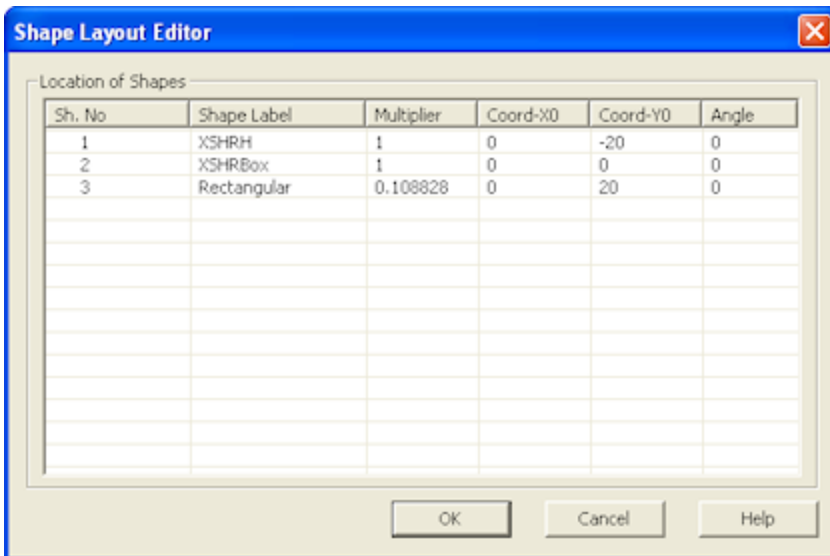

Click  to open the **Shape Layout Editor**. The Shape Layout Editor lists all shapes currently in the section and lets you view and edit the Label, Multiplier and position of each shape. The editor is a spreadsheet with each shape listed on it's own line and the columns are as follows:

Column Label	Description
Sh. No	Shape number (non-editable)
Shape Label	Description of the basic shape
Multiplier	Multiplier used for transformed section properties (1.0 implies the modulus of elasticity of steel)
Coord-X0	X-coordinate of the shape centroid
Coord-Y0	Y-coordinate of the shape centroid.
Angle	Rotation of the shape in the counter-clockwise direction.

Note: If your Section contains merged shapes, the Shape Layout Editor will by default only display the information pertaining to the overall (merged) Section. However, you can expand this to also show the properties of the individual merged shapes.

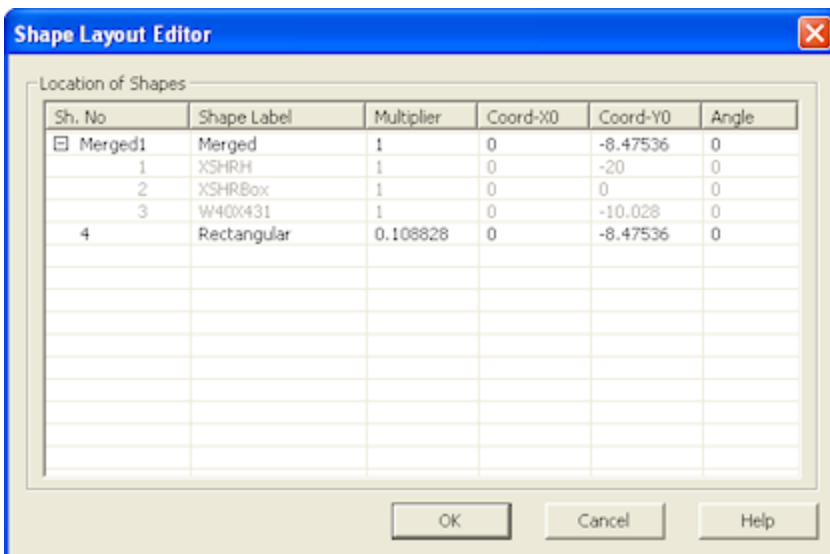

Solving for Properties

RISASection calculates most properties automatically as you edit the section. See the [Property Calculations](#) section for more information about what properties are calculated.

Saving Section Files

Sections are saved in files with a .nmsx extension by default. Multiple sections may be created and saved in one file, so you could have a file called STEEL.nmsx and one called CONCRETE.nmsx that store your steel and concrete shapes separately. You might name your files by project instead. That is completely up to you. All sections in a file are saved together by clicking  just once.

RISA-3D, RISAFloor, and RISA-2D look for all .nmsx files in the directory specified under **Tools - Application Settings- File Locations** tab and simultaneously provide a list of all sections that exist in any of the .nmsx files. You can see which sections are available by clicking on the shape database within RISA-3D, RISAFloor, or RISA-2D. Then click on the **General** tab or the **Hot Rolled** tab (depending on which Material you selected in RISASection). Under **Database/Manufacturer** you can select **RISASection**. You will then be able to see the sections available to you. The list provided is of the names of the sections within each section file, so it is important to use unique, descriptive names for each section you create.

See the [Integration](#) topic for more information.

Property Calculations

RISASection calculates most properties per *flat plate theory*. These properties are calculated automatically as you edit the section. If you notice that editing is going slowly for a larger file you can turn off automatic calculation in the **View** tab of the **Options** menu to manually calculate.

Note:

- The torsion constant J is not calculated automatically to allow for faster editing. To calculate the torsion constant click **J=**.

Important Assumption!

In order to use flat plate theory, RISASection relies on the input **Shape Type** (in the [Section Information](#) box) to calculate many of the properties. Therefore, it is especially important to designate your Shape Type properly. This is also used when exporting shapes for design in RISA-3D, RISA-2D, or RISAFloor. The member capacity checks are also dependent on Shape Type information so it is very important to know the assumptions.

It is important to set this properly!

Section Information	
File Name:	Built Up Column.nmsx
Section Name:	Section1
Material Type:	Hot Rolled Steel
Shape Type:	Tapered WF

Shape Type

The table below lists the assumptions for each Shape Type:

- General Material** -
 - Arbitrary** - This can be used for any shape type. No flat plate theory is used, so it is applicable for any and all shape types.. These shapes can be exported to RISA-3D, RISA-2D, and RISAFloor for analysis but they will not be able to be designed. This is because it is a catch-all shape and the other RISA programs will not know what code provisions would apply.
- Hot Rolled Steel Material** -
 - Channel** - This shape type assumes a typical *singly symmetric* channel section.
 - Wide Flange** - This shape type assumes a typical *doubly symmetric* wide flange section. Note: this assumes equal flanges. If you have a wide flange with unequal flanges, you want to designate it as a **Tapered WF**.
 - Single Angle** - This shape type assumes a typical non-symmetrical single angle section.
 - Double Angle** - This shape type assumes a typical *singly symmetric* double angle section.
 - Pipe** - This shape type assumes a typical *doubly symmetric* round pipe section.
 - Tube** - This shape type assumes a typical *doubly symmetric* square or rectangular tube section.
 - WT** - This shape type assumes a typical *singly symmetric* WT section.
 - Solid Round** - This shape type assumes a typical *doubly symmetric* solid round bar section.
 - Solid Rectangle** - This shape type assumes a typical *doubly symmetric* solid square or rectangular bar section.
 - Tapered WF** - This shape type assumes a *singly symmetric* wide flange section. This includes wide flange shapes with unequal flanges.

Note:

- For all of the Hot Rolled Steel shapes above, we assume also that the shape is in the default orientation. Rotating it may also effect the calculation of flange and web thicknesses, as well as other properties. See [Assumptions and Limitations](#) below.

Calculation Methodology

Closed Shapes

The geometric properties are computed with the Polygon method. All closed shapes are represented by closed polygons. Curvilinear and circular shapes or edges are represented by several straight line segments. The properties of the overall shape are computed by geometric summation of the properties.

Accuracy of the Polygon Method

The above method for computation of geometric properties is generally adequate for shapes of usual dimensions and proportions. The method may lose some of its accuracy for very oblong shapes, highly curvilinear shapes and for shapes with very small or very large dimensions. These errors are introduced due to numerical round-off and may be more pronounced in the results of for second moment of area. Every closed shape is defined by a set of lines and its properties can be calculated by combining the properties of the component individual lines.

Plastic Modulus, Z_x and Z_y

An iterative procedure is used to compute the plastic section modulus. The location of a "neutral axis" is determined that weighted areas above and below this line are equal. The plastic modulus is then computed as the moments of area about this neutral axis.

Torsional Constant J

For all general shapes, besides circles and pipes, a full finite element solution of the torsional stress distribution is used. The section is meshed with finite elements and solved to determine J . For circles and pipes, the exact formula for torsional constant J is used.

If you select a shape from the [RISA HR Database](#), then RISASection will instead read in the J value directly from the database.

Unless you merge your shapes using the [Merge](#) tool, the Torsional J calculation will simply be a summation of the individual shape's J values. Therefore it is recommended that you merge your Section for the most accurate results.

Additional Torsional Properties, C_w , W_{no} , S_w

When a section is designated as a pre-defined Hot Rolled [Shape Type](#), additional torsional properties (i.e. C_w , W_{no} , S_w , etc.) are calculated in order for the shape to be exported for design code checks in RISA-3D, RISAFloor, or RISA-2D. These properties calculated using the approximate formulas from [Formulas for Stress, Strain, and Structural Matrices](#) by Walter D. Pilkey. This is done to save in solution time and to match as accurately as possible with hand calculation methods.

Important Note:

- These approximate formulas used to calculate C_w , W_{no} , etc. depend on the Flange Thickness and Web Thickness values. This means that if your shape is far from the pre-defined shape type, or if the orientation is different than the default, the thickness values can be calculated very wrong. See [Assumptions and Limitations](#) below for details on how the thickness values are calculated.
- Since the program cannot guarantee these values, we make them editable for the user. Simply highlight the value in the **Properties** window and type in another value. If you are changing these, it is important to

also uncheck the **Auto** buttons associated with them because you will need to click the **Solve** button once more to recalculate the torsional properties with these values. See [Editable Properties](#) below.

Thin Walled Assumption

Most of the approximate formulas used to calculate the torsional properties are also dependent on the assumption that the section applies to thin-walled theory. To check this, RISASection internally checks that:

$$\frac{t_{max}}{b} \leq 0.1$$

If the section does not meet this limit, you will be presented with a Warning Message at solution.

Built-up and Composite Sections

The properties of a built-up or composite section are computed by weighted summation and transformation of individual shape properties to the section centroid. The weight of the shapes is based on the relative ratio of the modulus of elasticity of individual shape to that of the base material.

For additional advice on this topic, please see the RISA News website: www.risanews.com. Type in Search keyword: **Composite**.

A **Property Multiplier** is used to specify the relative weight of the shape's Modulus of Elasticity in the overall section. It is the ratio of the Modulus of Elasticity of a particular shape to the Base Modulus of Elasticity (which may be edited in the **Section Properties** tab of the **Options** menu). This factor may be assigned a fixed value for each shape, or it may be computed automatically by the program as the ratio of the Modulus of Elasticity of the shape material and that of the Base Material.

Any positive, negative or zero value may be specified:



- 1 or a positive value = Solid or positive Shape
- 0 = Ignore the Shape in properties calculations
- 1 or a -negative value = Void or hole or a negative Shape

Note that when using a negative value for a hole, you want to make sure that the negative property value that you use is the negative of the property multiplier that you are putting your hole onto. For example, if steel is your material and you are punching a hole into a solid section, you want your modulus of elasticity for your steel to be 29000 ksi and the modulus of elasticity for your hole to be -29000 ksi.

For additional advice on this topic, please see the RISA News website: www.risanews.com. Type in Search keywords: **RISASection Void**.

You may specify the property multiplier in one of two ways. Double-click a shape, in the workspace to open the editor and specify the modulus of elasticity and we will modify the property multiplier accordingly. Alternatively, click  to view the layout of all shapes currently in the section. The table also shows the multiplier for each shape, which you can modify manually.

Section Properties

The calculated [Section Properties](#) (described below) are listed on the lower right window. With the **View Options** on the **Option** menu you may have properties calculated automatically as you build and edit a section or manually by clicking . Click  to calculate the torsional constant J, which may not be calculated automatically. You may print the properties for the current section by clicking  or create a report that contains multiple sections.

You may calculate transformed properties for composite sections that have shapes of different materials. To do this use the [property multiplier](#) to distinguish between the different material types.

Basic Calculated Properties

These properties are calculated for all shapes, regardless of Material or Shape Type.

Property Label	Description
Total Width and Height	Total overall width and height of the section.
Centroid, X _o	Horizontal distance from the global X-axis origin to the centroid of the section.
Centroid, Y _o	Vertical distance from the global Y-axis origin to the centroid of the section.
X-bar (Right and Left)	Distance from the centroid of the section to the extreme right and left fiber.
Y-bar (Top and Bot)	Distance from the centroid of the section to the extreme top and bottom fiber.
Area, A _x	Total area of the section.
Inertia, I _{xx} and I _{yy}	Moment of inertia about the global X and Y axes.
Inertia, I _{xy}	Product moment of inertia.
Torsional J	Torsion constant.
S _x (Top and Bot)	Elastic section modulus of the extreme top and bottom fibers.
S _y (Left and Right)	Elastic section modulus of the extreme left and right fibers.
r _x and r _y	Radius of gyration about x and y.
Plastic Z _x and Z _y	Plastic section modulus about x and y.

Additional Calculated Properties

In addition to the properties above, the following properties may also be calculated. Their inclusion depends on the **Material** and **Shape Type** selection in the [Section Information](#) window.

Property Label	Description
Max Thick	Maximum thickness of the section.
Flange Thick	Thickness of the flange.
Web Thickness	Thickness of the web.
Leg Thickness	Thickness of the leg of a single angle.
Space	Space in between the back to back legs of a double angle.
Thickness	Wall thickness (such as for a tube or pipe section).
As-xx Def	Shear deformation factor about the xx axis.
As-yy Def	Shear deformation factor about the yy axis.
As-xx Stress	Shear stress factor about the xx axis.
As-yy Stress	Shear stress factor about the yy axis.
Shear Center, X _s	Horizontal distance between the centroid and the shear center.
Shear Center, Y _S	Vertical distance between the centroid and the shear center.
eo	Distance from the outside web of a channel to the shear center.
ro	Polar radius of gyration about the shear center.
r _T	Radius of gyration of a portion of the section including the upper flange plus 1/3 of the web area, taken about the X axis.
r _Z	Radius of gyration about the Z axis (principal axes for single angles).

Cw	Warping constant for the section.
Wno	Normalized warping function at a point on the flange edge.
Sw	Warping statical moment.
Qf	Statical moment of the flange.
Qw	Statical moment of the cross section.
Total Width (Top)	Tapered wide flange top flange width.
Total Width (Bot)	Tapered wide flange bottom flange width.
Flange Thick (Top)	Tapered wide flange top flange thickness.
Flange Thick (Bot)	Tapered wide flange bottom flange thickness.

Assumptions and Limitations

There are some properties (Flange and Web Thickness, Flange Width, Shear Center) whose values are dependent on the shape's orientation. For example, the internal calculation for the Flange Thickness of a Wide Flange shape assumes that the shape is oriented in its default position.

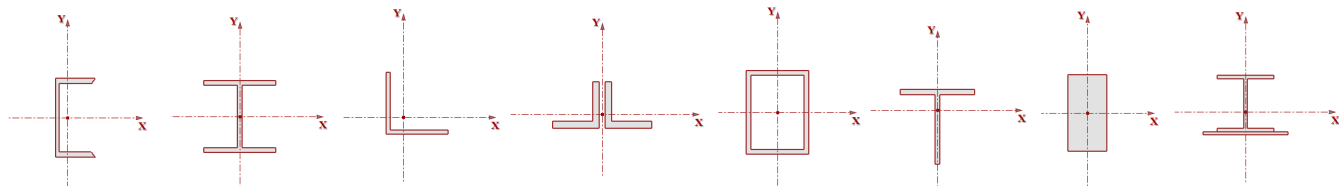

Even in the correct orientation, it sometimes can be difficult for the software to determine some of the property values. The most obvious of these is thicknesses. Thicknesses can be difficult to determine for built-up shapes and sometimes require engineering judgment. Therefore, you may manually edit these properties in the [editable properties](#) region of the property grid.

RISASection uses the following methods to determine the following properties:

Flange Thickness

The Flange Thickness value for Channel, Wide Flange, and W_Tee shapes is determined by taking 10 vertical cuts through the entire section. RISASection then finds the smallest non-zero thickness and divides by two.

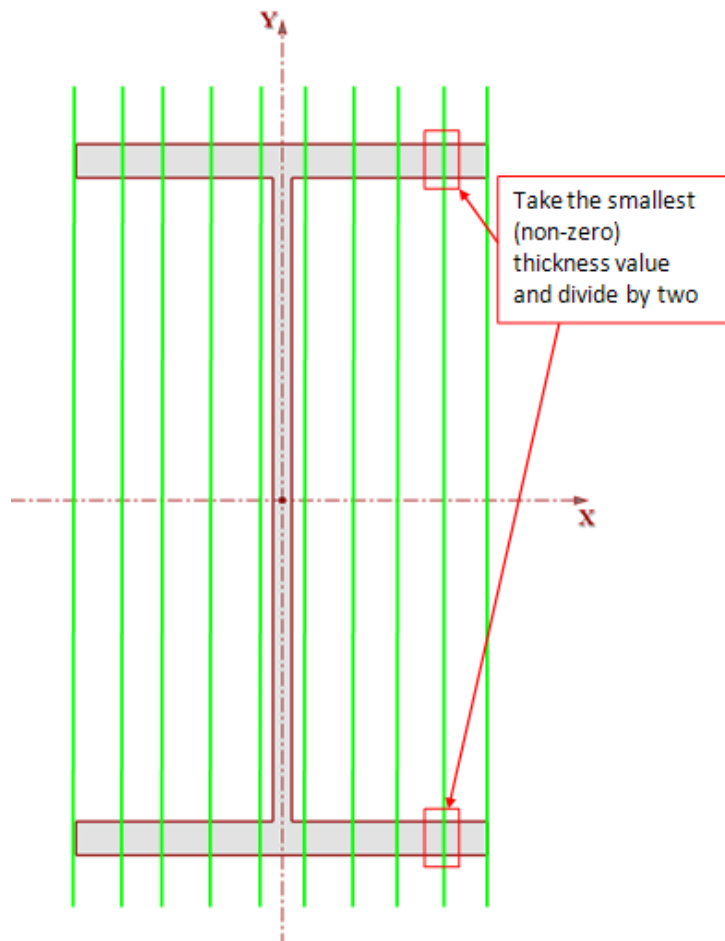

Web Thickness

The Web Thickness value for Channel, Wide Flange, and W_Tee shapes is determined by taking a horizontal cut at the mid-height of the entire section. The thickness at this location is taken as the web thickness.

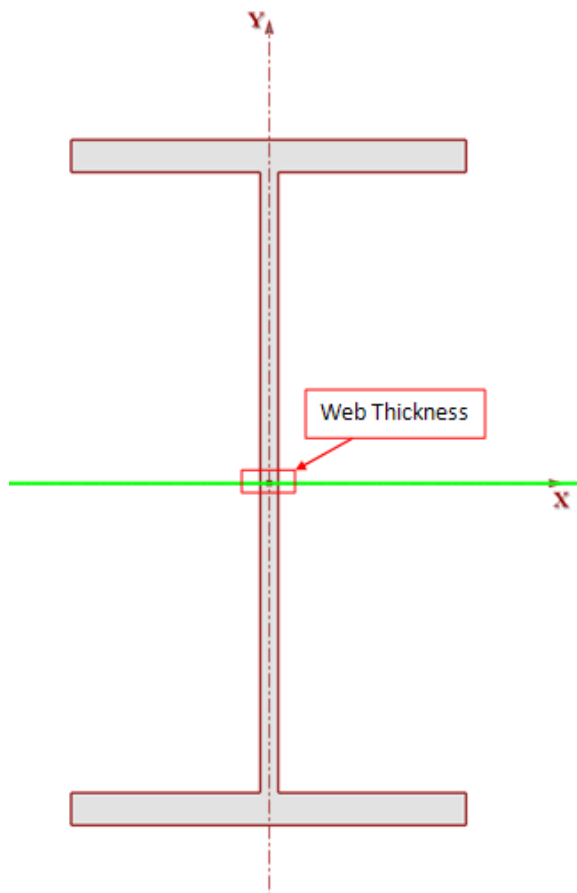

r_T

r_T is only available for Wide Flange sections that are assumed to be doubly symmetrical. This is taken as the radius of gyration of the *top* flange plus one third of the web area, taken about the X axis. This calculation is done using the Web and Flange Thicknesses defined above.

Leg Thickness

The Leg Thickness value for Single and Double Angles is determined by taking 10 vertical cuts across the width of the entire section. RISASection then takes the smallest non-zero value as the Leg Thickness.

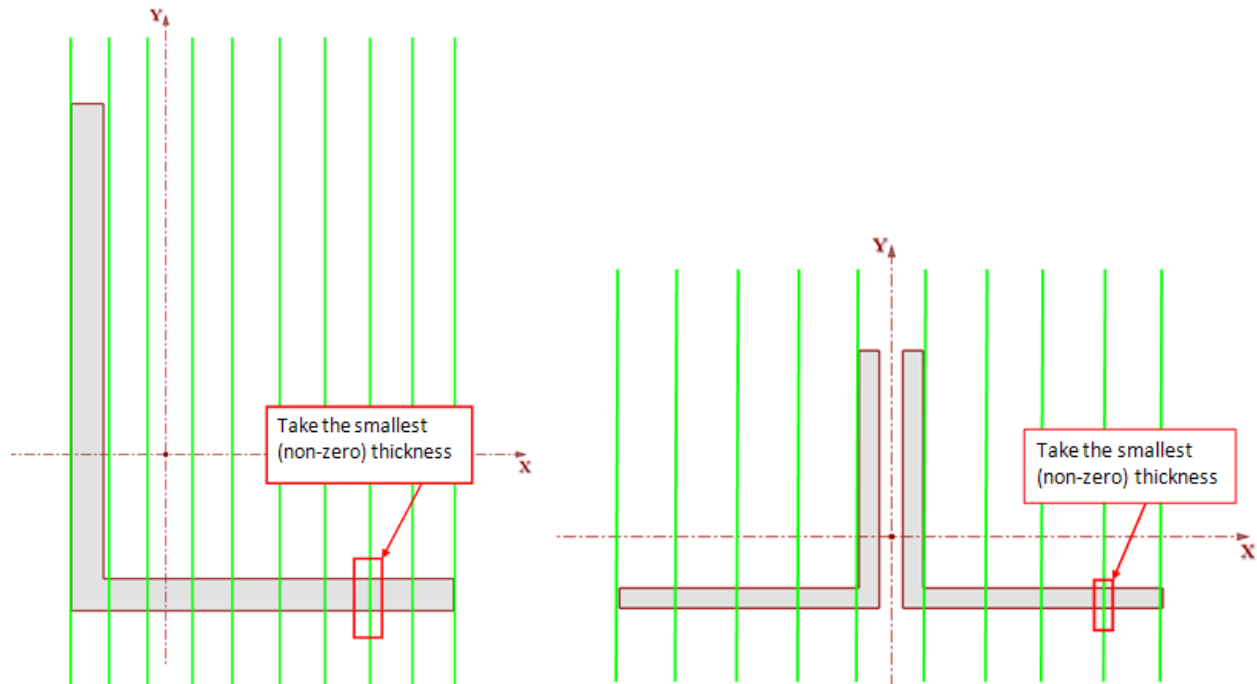

Space

RISASection makes no attempt to determine the space between a Double Angle shape. Therefore, the automated value for this will always be set to zero.

Thickness

The Thickness value for Pipe and Tube shape types is determined by taking 10 horizontal cuts along the height of the entire section. RISASection then takes the smallest value and divides by two for the Thickness.

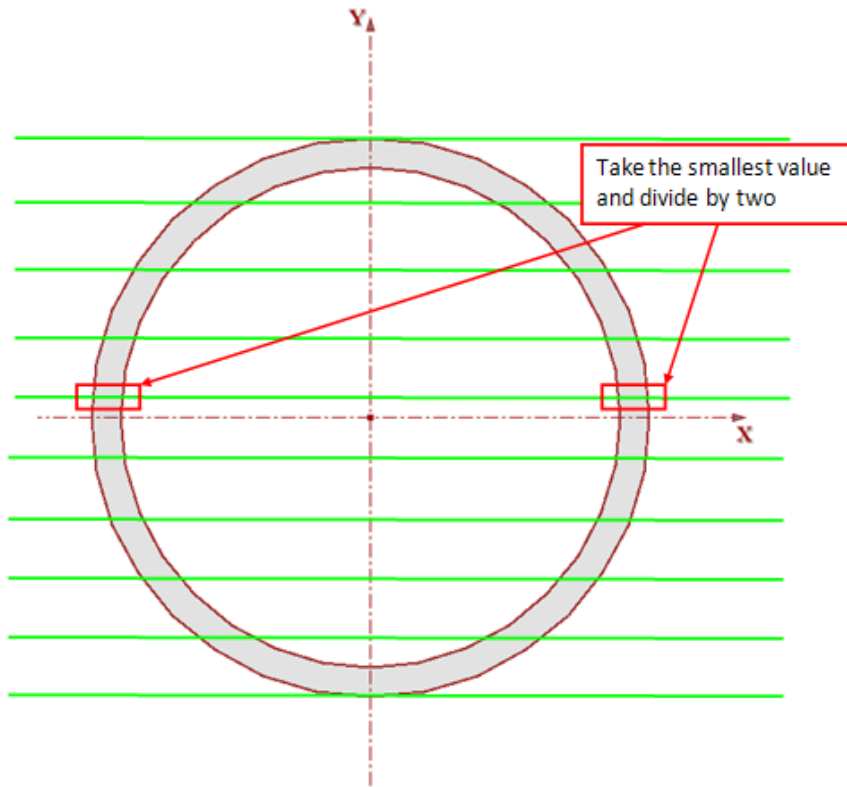

Total Width (Top) and Total Width (Bot)

The Total Width (Top) and Total Width (Bot) values for Tapered Wide Flange shapes are determined by taking 10 horizontal cuts along the height of the entire section. RISASection then takes the width at the top cut as the Total Width (Top) value and the width at the bottom cut as the Total Width (Bot) value.

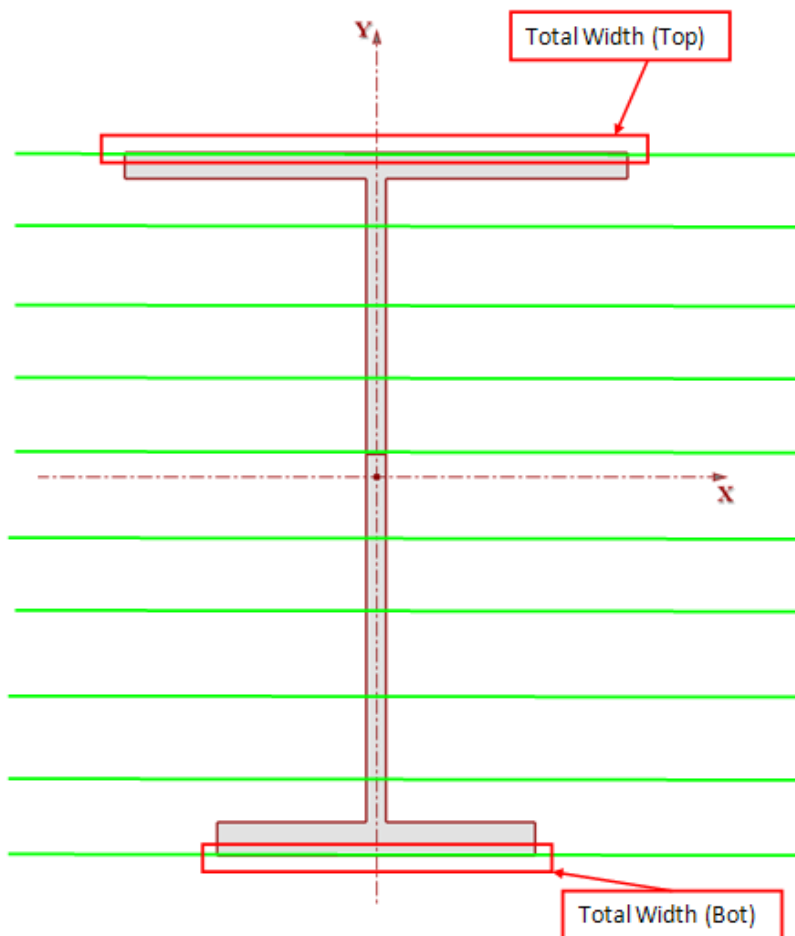

Flange Thick (Top) and Flange Thick (Bot)

The Flange Thick (Top) and Flange Thick (Bot) values for Tapered Wide Flange shapes will always be equal, unless the user overwrites them with manually entered values. RISASection determines the Auto value by taking 10 vertical cuts along the width of the entire section. Then, it takes the smallest non-zero thickness value and divides by two for the Flange Thick (Top) and Flange Thick (Bot) values.

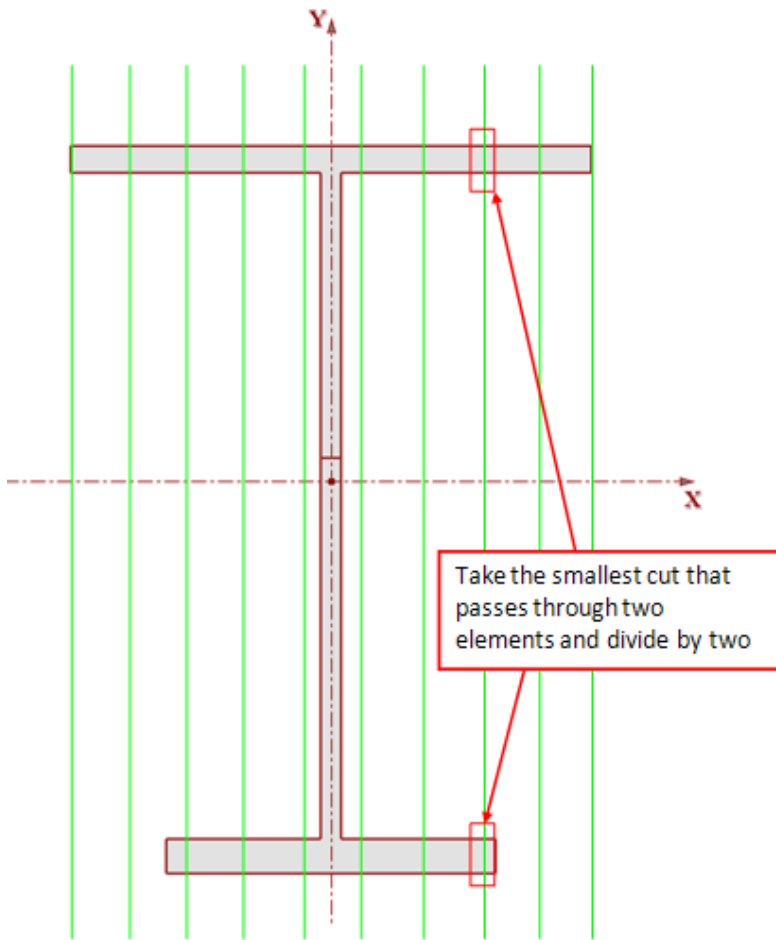

Editable Properties

RISASection uses approximate calculations to calculate the torsional properties C_w , W_{no} , S_w , Q_w , and Q_f for Hot Rolled shapes. These approximate formulas depend on the assumed properties above. Due to complex built up shapes, there may be times where these are not quite accurate. Therefore, we recommend that you always verify these values against your shape. If our simplified method does not capture the correct value, simply edit it in the **Properties** window. All the properties that are effected by these values are grouped beneath the solid black line, so you should be able to quickly see the changes take effect.

Auto	Properties		
	Total Width =	10.000	in
	Total Height =	20.000	in
	Centroid, X _o =	-0.000	in
	Centroid, Y _o =	-0.000	in
	X-Bar (Right) =	6.974	in
	X-Bar (Left) =	3.026	in
	Y-Bar (Top) =	10.000	in
	Y-Bar (Bot) =	10.000	in
	Area, A _x =	42.667	in ²
	Inertia, I _{xx} =	2650.07	in ⁴
	Inertia, I _{yy} =	379.30	in ⁴
	Inertia, I _{xy} =	0.000	in ⁴
	S _x (Top) =	265.01	in ³
	S _x (Bot) =	265.01	in ³
	S _y (Left) =	125.35	in ³
	S _y (Right) =	54.389	in ³
	r _x =	7.881	in
	r _y =	2.982	in
	Plastic Z _x =	311.85	in ³
	Plastic Z _y =	105.78	in ³
<input checked="" type="checkbox"/>	Flange Thick =	1.212	in
<input checked="" type="checkbox"/>	Web Thick =	1.000	in
	Shear Center, X _s =	-6.343	in
	Shear Center, Y _s =	0.000	in
	r _o =	10.894	in
<input checked="" type="checkbox"/>	Torsional J =	19.959	in ⁴
	C _w =	2.522E+004	in ⁶
	e _o =	3.234	in

Auto Resolve Options

Some of the additional calculated Properties offer a **Auto** checkbox in the **Properties** window.

Auto	Properties		
	Total Width =	20.000	in
	Total Height =	20.000	in
	Centroid, Xo =	0.000	in
	Centroid, Yo =	-8.475	in
	X-Bar (Right) =	10.000	in
	X-Bar (Left) =	10.000	in
	Y-Bar (Top) =	10.000	in
	Y-Bar (Bot) =	10.000	in
	Area, Ax =	76.444	in ²
	Inertia, Ixx =	5184.53	in ⁴
	Inertia, Iyy =	1368.23	in ⁴
	Inertia, Ixy =	0.000	in ⁴
	Sx (Top) =	518.45	in ³
	Sx (Bot) =	518.45	in ³
	Sy (Left) =	136.82	in ³
	Sy (Right) =	136.82	in ³
	rx =	8.235	in
	ry =	4.231	in
	Plastic Zx =	595.16	in ³
	Plastic Zy =	235.65	in ³
<input type="checkbox"/>	Flange Thick =	1.000	in
<input checked="" type="checkbox"/>	Web Thick =	0.500	in
<input checked="" type="checkbox"/>	rT =	5.569	in
	Shear Center, Xs =	0.000	in
	Shear Center, Ys =	0.000	in
<input checked="" type="checkbox"/>	Torsional J =	59.700	in ⁴
	Cw =	1.204E+005	in ⁶
	Wno =	95.000	in ²
	Sw =	475.00	in ⁴
	Qf =	92.625	in ³
	Qw =	210.25	in ³

This checkbox controls which of the editable properties will be determined automatically per the shape graphic. RISASection will attempt to calculate these values upon solution, but because they are not always exact, you have the ability to overwrite the RISASection value with your own. Simply click on the value in the **Properties** window to highlight the entry and then type in your value.

The **Auto** checkbox controls whether or not these values will be re-populated if you click the **Solve**  button after overwriting these values.

Integration with RISA-3D, RISA-2D, and RISAFloor

Interaction with RISA-3D, RISA-2D, and RISAFloor

RISA-3D, RISA-2D, and RISAFloor programs may all read in RISASection custom shapes. These programs all "look" for RISASection (.nmsx) files in the directory specified under **Tools -Application Settings-File Locations** tab.

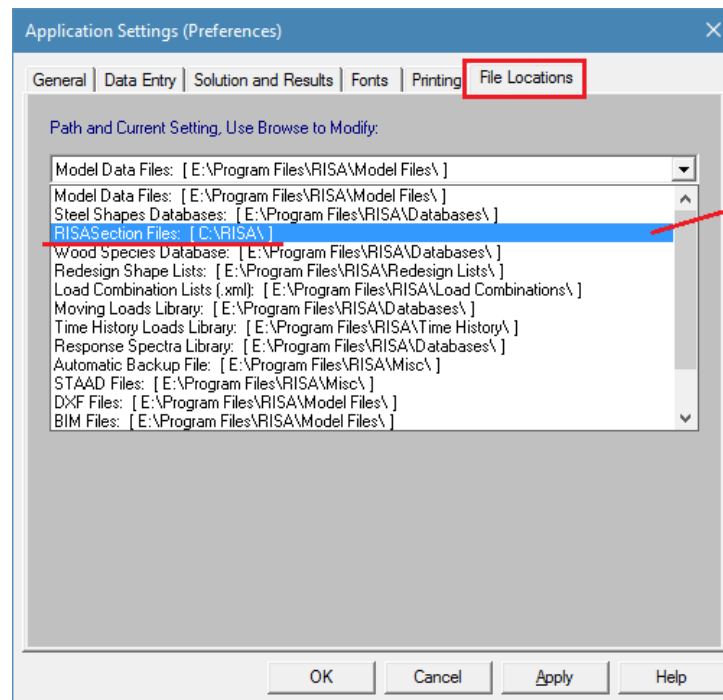

You can see which sections are available in your design program by clicking on the **Shape Database** button . Shapes that are designated as Hot Rolled Steel Material Type in RISASection will be found in the **Hot Rolled** tab of the Shape Database under the RISASection **Database/Manufacturer**.

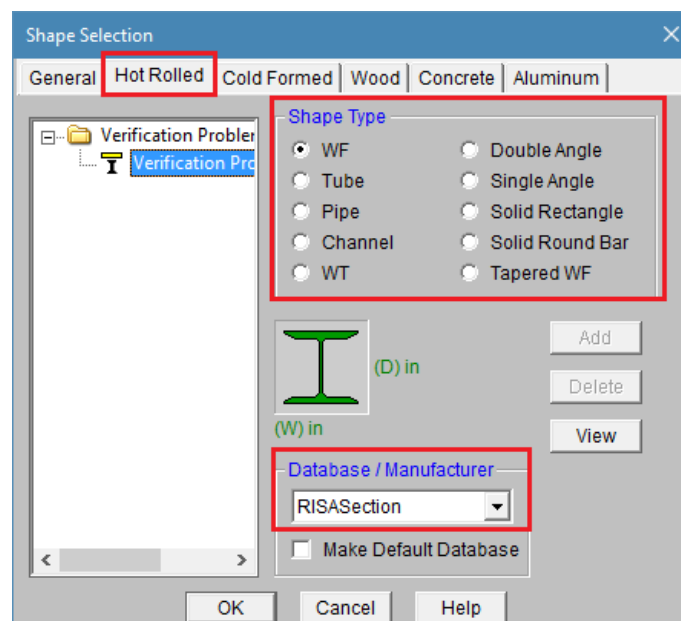

Shapes that are designated as General Material Type in RISASection will be found on the **General** tab under the RISASection **Database/Manufacturer**.

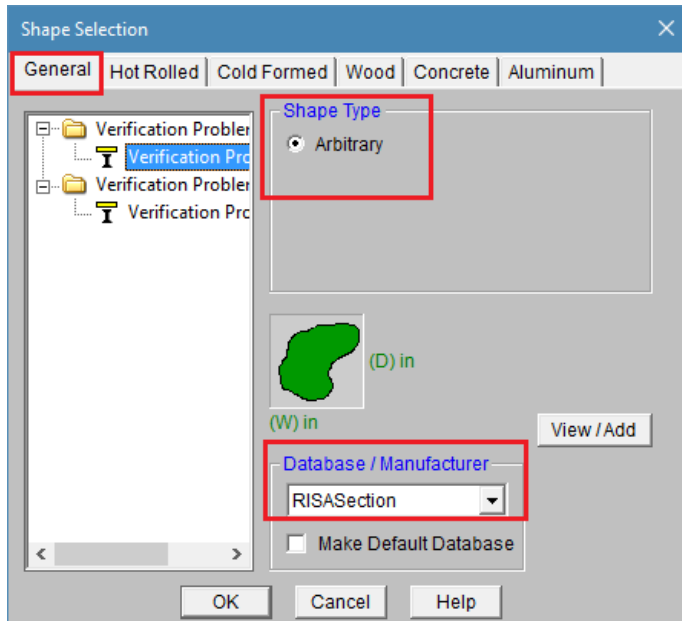

Make sure to select the proper material tab, Shape Type, and Database

Troubleshooting Integration

If you are having trouble finding your RISASection shape within RISA-3D, RISA-2D, or RISAFloor, please refer to the following troubleshooting suggestions.

Common RISASection Mistakes:

1. Be sure to give both the **Section Name** and the **File Name** unique labels. Each RISASection file can contain multiple Sections so it is important to give them all individual names. Both the Section names and the File names show up in the Shape Database, so you will be able to see what Sections are contained in each File.
2. Make sure that you have properly assigned each Section a **Material Type** and **Shape Type**. Your Section will show up in the proper location of the Shape Database depending on these designations.

Section Information	
File Name:	Verification Problem 3.nmsx
Section Name:	Verification Problem 3_C9X20
Material Type:	Hot Rolled Steel
Shape Type:	Channel

Common RISA-3D/2D/Floor Mistakes:

1. Make sure that you are running version 9.1.0 or higher of RISA-3D, version 5.1.0 or higher of RISAFloor, or version 10.1 or higher of RISA-2D. integration with RISASection version 2.0 and 2.1 is only available in these versions or newer.

2. Make sure that you have selected the correct **Material** tab (**General** or **Hot Rolled**), and Shape Type, as

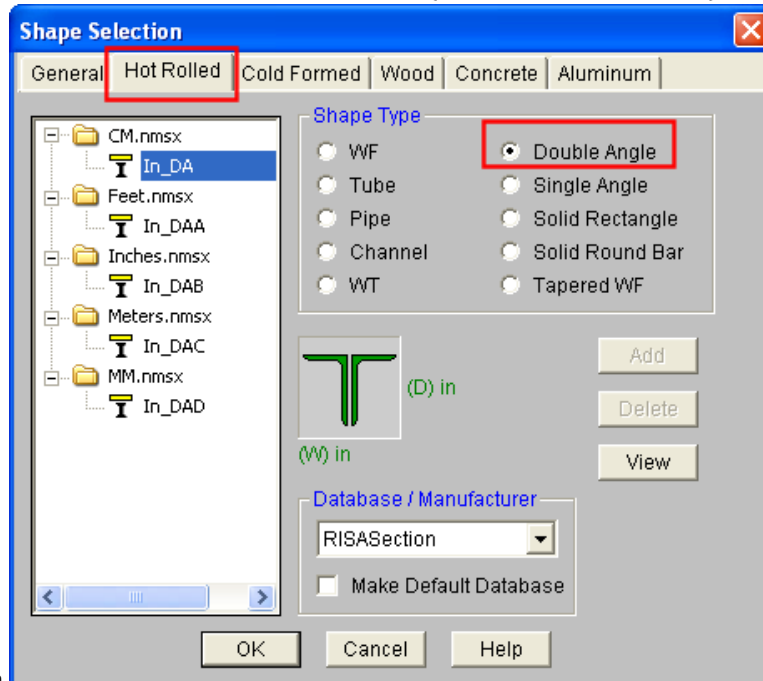

assigned in RISASection.

3. Make sure that you have **"RISASection"** selected from the **Database/Manufacturer** menu.

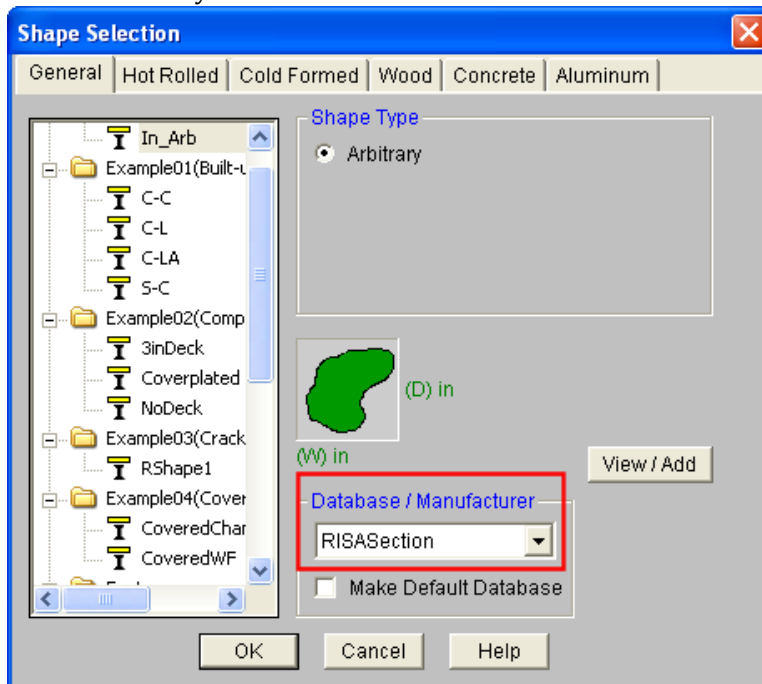

4. Go to **Tools – Application Settings– File Locations** and check the location for RISASection files. Make sure that you have saved your RISASection files to this location since RISA-3D/2D/Floor will only search

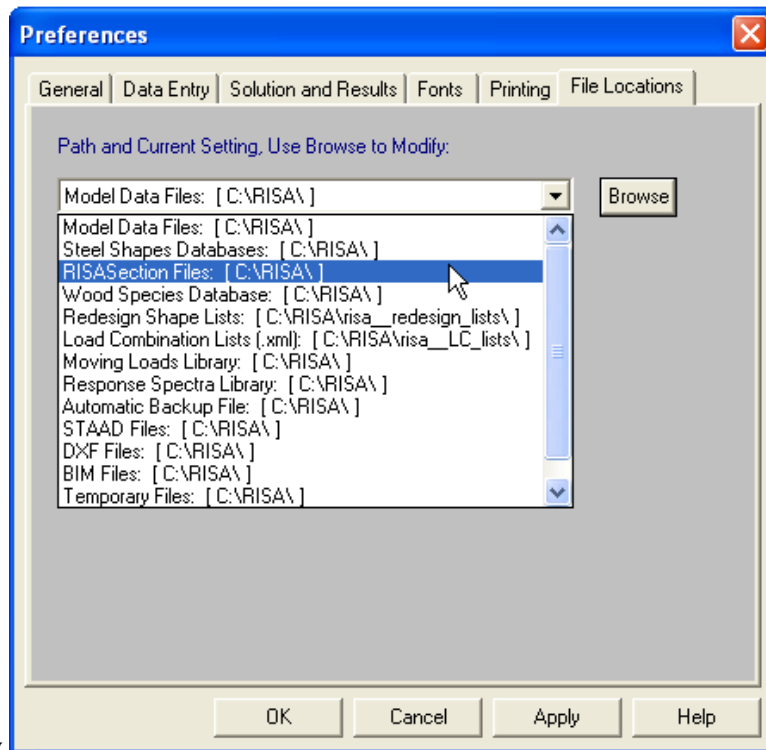

for RISASection files in this directory.

5. RISA-3D/2D/Floor only read in RISASection files when the program is first launched. Therefore, be sure to close and restart the program after creating and saving the file in RISASection.

DXF Import

DXF Import Procedure

To Import a DXF Section

1. Draw the outline of the section in your CAD program. If you have multiple shapes defined in one DXF file, we recommend that you place them on separate layers in your CAD program.
2. Save the file as a DXF file.
3. Open RISASection (you can open a new file or an existing file).
4. Go to **File - Import DXF File** and browse to select your DXF file.

Notes:

- RISASection will only import 2D shapes from your CAD model.
- It is recommended that you separate any built up sections onto separate layers in the DXF file. For instance, if you are modeling a cap channel, you should model the wide flange shape on one layer and the channel on another. This helps the import function to clearly separate the shared lines between the two for a more accurate import.
- The program will warn you if your DXF, or part of your DXF cannot be imported.
- The program will always import a DXF section as a New Section in your file. Therefore, if you want to add shapes to it within the program you must import first and then add shapes later.

For additional advice on this topic, please see the RISA News website: www.risanews.com. Type in Search keywords: **DXF Import**.

Import DXF Options

After selecting your DXF file, the program will offer you options for the import in the Import DXF File dialog so that you insure an accurate import.

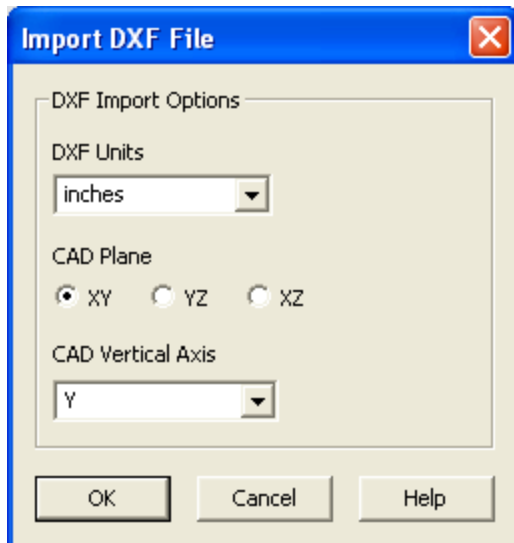

The options are as follows:

DXF Units

This selection allows you to define which units you used in the CAD model. Therefore, if your CAD model was created using millimeters and the RISASection file defaults to inches, the import feature will automatically convert

the dimensions.

In addition to the standard unit options, you may also chose **None** as your DXF Units. This simply means that no unit conversion will be taken into account. The dimension magnitudes that you entered in CAD will be taken as they are for the RISASection model. These magnitudes will then be assigned units based on the default units set in RISASection.

CAD Plane

This selection defines which plane you drew your two dimensional section in the CAD model.

CAD Vertical Axis

The implied default vertical axis in AutoCAD is the positive Z-axis of the current User Coordinate System. The default vertical axis in RISASection is the positive Y-axis. Therefore, when you import your model from a DXF file, you can have the program automatically rotate your geometry so that the Y axis is now the vertical axis for your RISASection model.

Invalid DXF Shapes

RISASection currently only imports Lines, Polylines, Arcs, and Circles. The program will NOT import the following shapes from DXF:

- Single line segments (try a polyline instead)
- Open outlines (such as a U shape)
- Spline line types
- Ovals / Ellipses.

Options

You can edit the program options by using the **Options** menu.

General Options

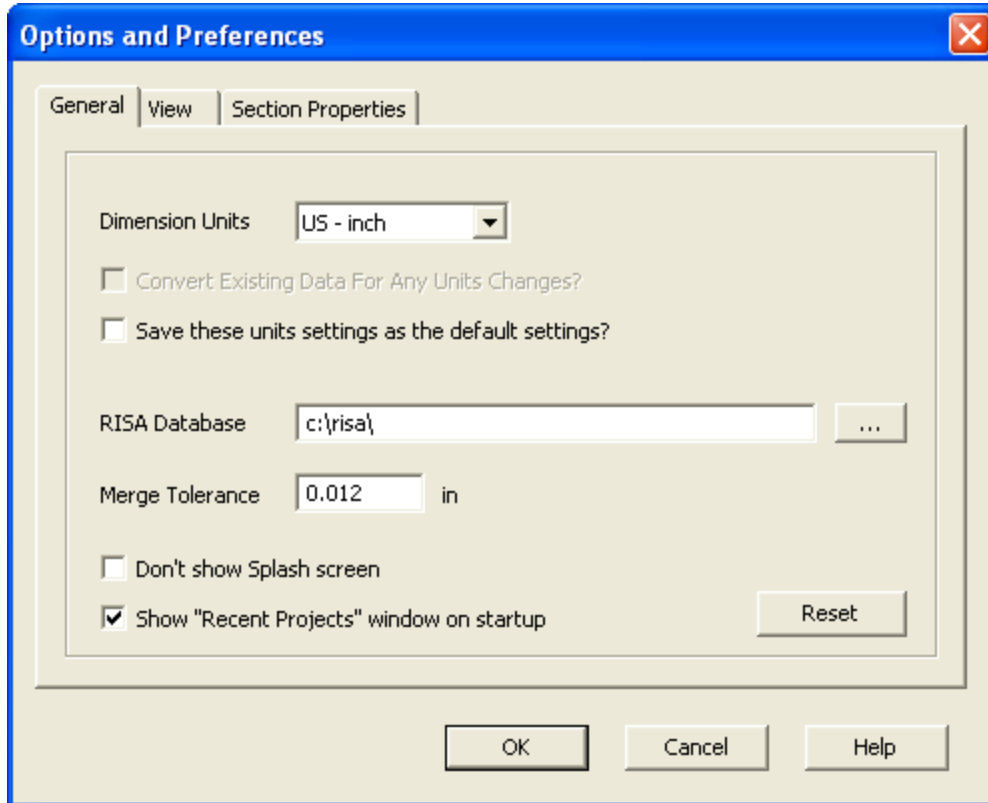

Dimension Units

You may adjust the units at any time by selecting the units system from the drop down list.

You can work with imperial (inches, feet, etc.) or metric (centimeters, millimeters, etc.) units. You may also change units at any time and RISASection will automatically perform the conversion.

RISA Database

The RISA Database designates where your RISASection files are being read from and written to. The Hot Rolled Steel database files (AISC, Canadian, Euro Shapes, etc.) are read in from this location, and any RISASection file that you save will by default, save to this location.

It is a good idea to check the location of where your RISA-2D, RISA-3D, and RISAFloor programs look for RISASec- tion files and then set this to the same location. To check this, open RISA-2D, RISA-3D, or RISAFloor and go to **Tools - Application Settings - File Locations**. Find the file path where **RISASection** files are located.

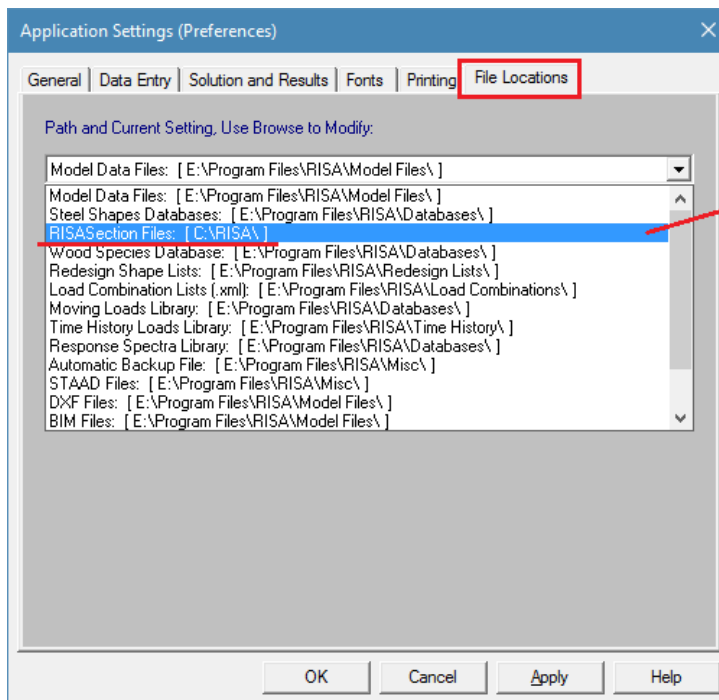

Merge Tolerance

This distance controls how close two shapes have to be to one another in order to be merged together using the [Merge](#) tool.

Startup Checkboxes

The other two checkboxes refer to startup options.

View Options

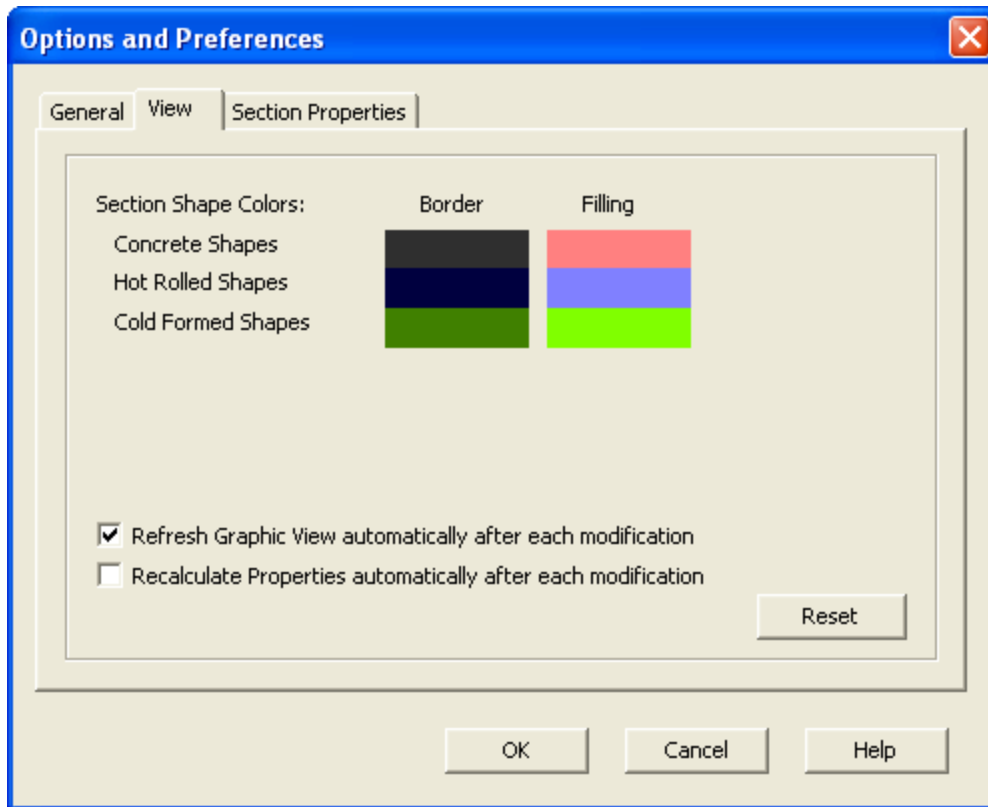

Colors

Change the **Border** colors to change the colors used in the workspace and the **Filling** colors to change the rendered view. Simply click on the color that you want to change and you will be offered a palette from which to choose your new color.

Views

By default the views update automatically. If you disable automatic features, then the Rendered window and the Properties window will not update until you click the solve button.

Section Property Options

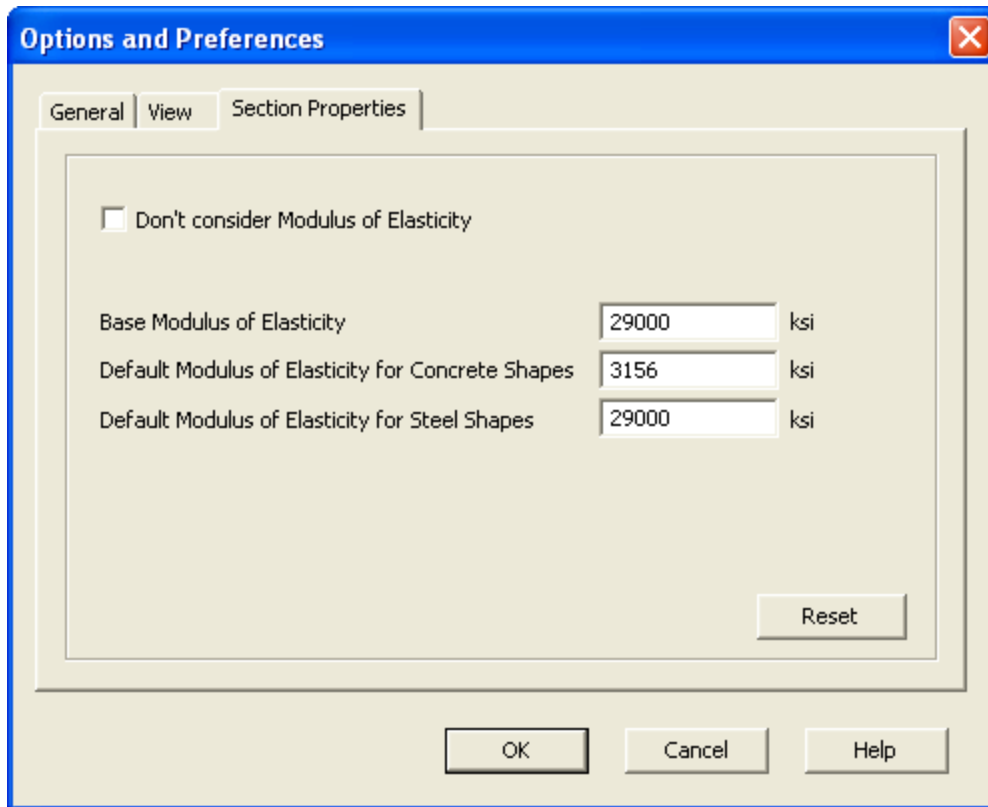





To compute transformed section properties for sections that contain different materials you may specify the **Base Modulus of Elasticity**. This value represents the property for the base material and other materials will be converted to align with the base value. Here you can also define default values for concrete or steel. Note that when creating shapes you can always manually modify this value as well. If you don't want the program to consider differences in stiffnesses for different materials, you can select **Don't consider Modulus of Elasticity**. For more information on stiffnesses and property multipliers, see [Property Multiplier](#).

Printing

Preparing Report and Printing

You may print one section at a time or print a report that contains multiple sections.

- To print the properties and a diagram of the current section click the **Print Current Section** button .
- To create a report, activate the **Report Wizard** by clicking .
- To add a view to a report click .
- To preview a report that has already been created click **Preview Current Report** .
- To print a report that has already been created click **Print Current Report** .

Report Creation Wizard

As the name indicates it helps us to prepare the report in a systematic way. It may be opened by the Report Creation Wizard button  or by selecting **Report Creation Wizard** from the **Results** menu. As shown in the following screen capture, different check boxes are provided to select the items of interest. These items are divided into two groups. Once the required items have been added/selected we can press the **Generate Report** button to finish the report generation process.

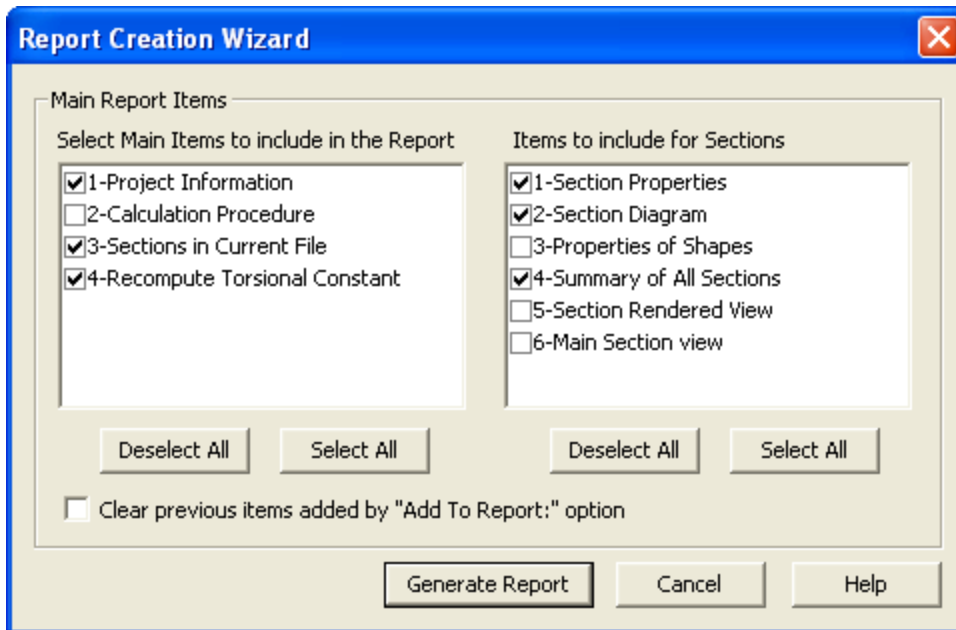

Main Report Items are listed on the left side of the Report Creation Wizard.

Main Report Items	Description
Project Information	Includes the project information at the top of the report.
Calculation Procedure	Includes the calculation procedure at the beginning of the report.
Sections in Current File	Includes the items selected in the right pane (see below) for each section in the current file.
Re-compute Torsional Constant	Will re-compute the torsional constant again at the time of report generation.

Section Items are listed on the right side of the Report Creation Wizard.

Section Items	Description
Section Properties	Includes the calculated properties for each section.
Section Diagram	Includes the diagram for each section.
Properties of Shapes	Includes the properties for the basic shapes in each section.
Summary of All Sections	At the end of the report this summarizes each section in one line that includes the name, width, height, centroid, area and inertias for each section.
Section Rendered View	Includes a graphic image of the Rendered View .
Main Section view	Includes a graphic image of the main Section view (what is visible in the Workspace).



Previewing Current Report

To preview a report that has already been created click . Once the preview is open you can adjust the view and print the report. The toolbar along the top provides options to print, move page by page or jump to the start and end of the report and zoom in and out. You may also close the report without printing. The same options are available on the small toolbar along the bottom left of the preview.

Add Current View to Report

To add the current view in the report it may be done by the clicking  or by selecting **Add to Report** from the **Section** menu. The added view then can be viewed and printed by the Report Manager.

Print Current Report

Any graphic view, currently being displayed on any port, can be sent for printing by clicking  located on a toolbar appearing at the top of the respective view port. This is useful for quick printing of the current view without having to go through the Report Manager/ Wizard. The current view can be added to the report by pressing **Add Current View to the Report**  button, which can be customized and printed later.

Examples

These examples are designed to teach you about the features that are available so that you may then build any shape that you need. The process is similar for all sections you will use basic shapes from the library to describe each section. The shapes will be taken from the library and placed in the workspace. You will then rotate, align and stack the shapes to configure the section. This process will be repeated for each section that you want to describe in the file and then you will simply print a report and save the file.

Because each file can contain multiple sections, you will also learn how to rename sections and designate them with Material and Shape Type for [import](#) into RISA-2D, RISA-3D, or RISAFloor.

Built-Up Shapes Examples

In this example we will define two steel sections in one file. The first will be a tapered wide flange, and the second will be a wide flange with a cap channel.

Tapered Wide Flange Example

Note - You may click the Undo button at any time to correct mistakes.

1. Start RISASection by clicking the shortcut on your desktop or selecting it from the Windows **Start** menu. RISASection will open a new file and present you with the **Starting a Model** dialog.

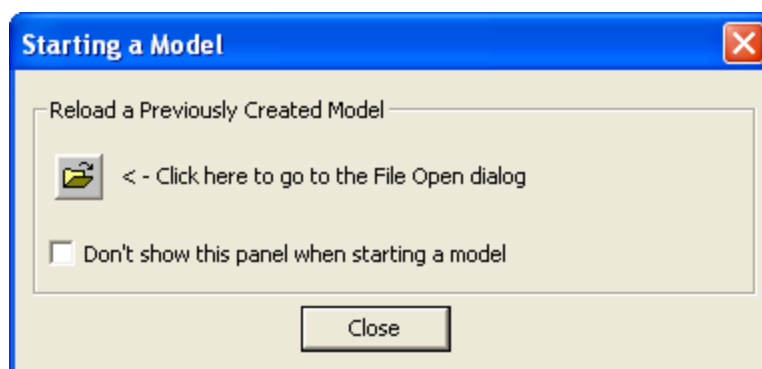

2. This dialog allows you to quickly access previous files. However, you will be starting a fresh model in this example, so click **Close** to close the dialog.

3. Click the **Rename Section** button  from the RISA Toolbar. Type in "Tapered Wide Flange" and click **OK**.

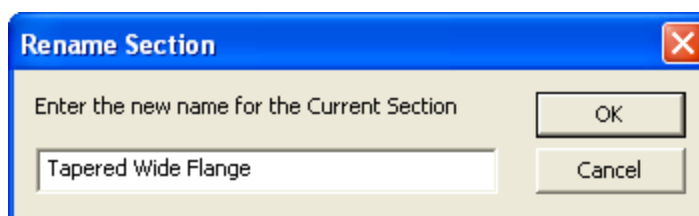

4. On the left side of the application, under **Shape Library**, click **Basic Steel Shapes**. Double-click the **Tee Section** shape it will be added to the workspace.

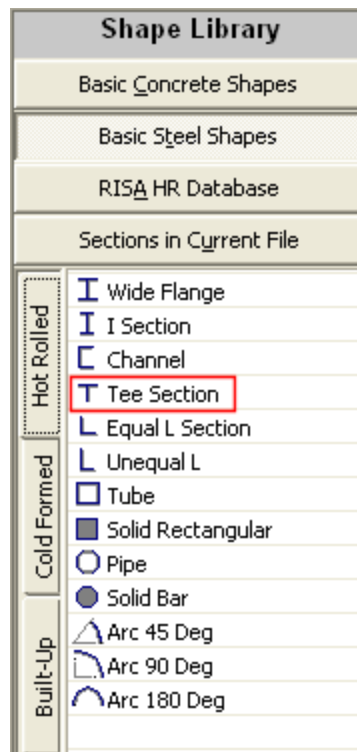

5. Edit the shape properties in the **Shape Editor**. To open the **Shape Editor**, double-click the edge of the shape that is now in the workspace.

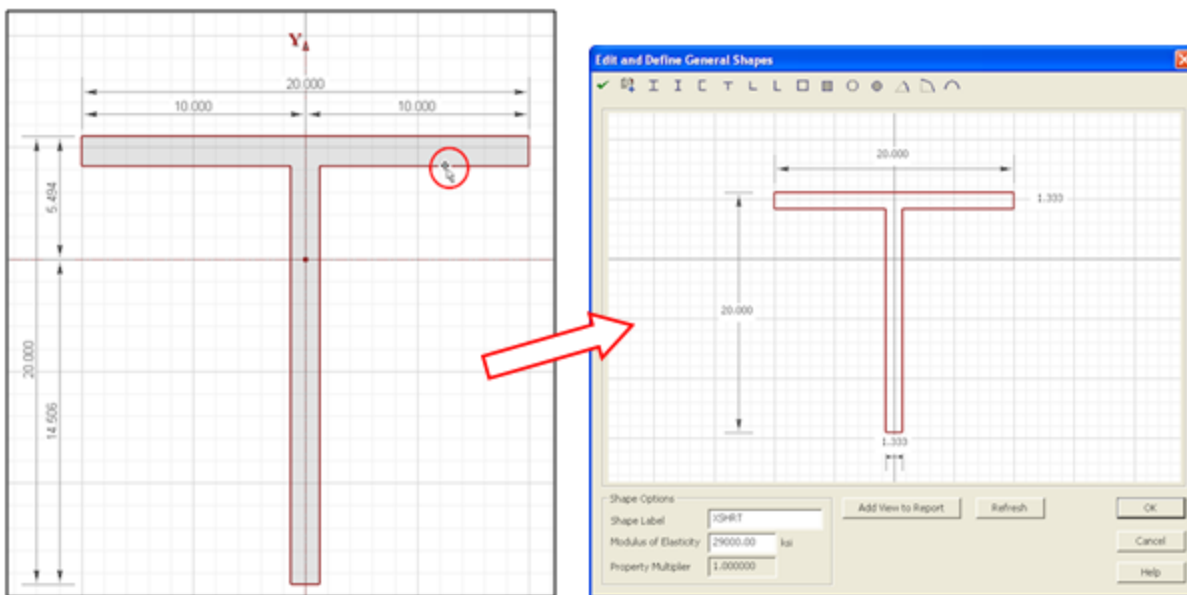

6. Change the flange width by clicking in the top dimension box and type "12". Repeat to change the flange thickness to 1", the depth to 11" and the web thickness to 0.75". Click **OK** to close the editor.

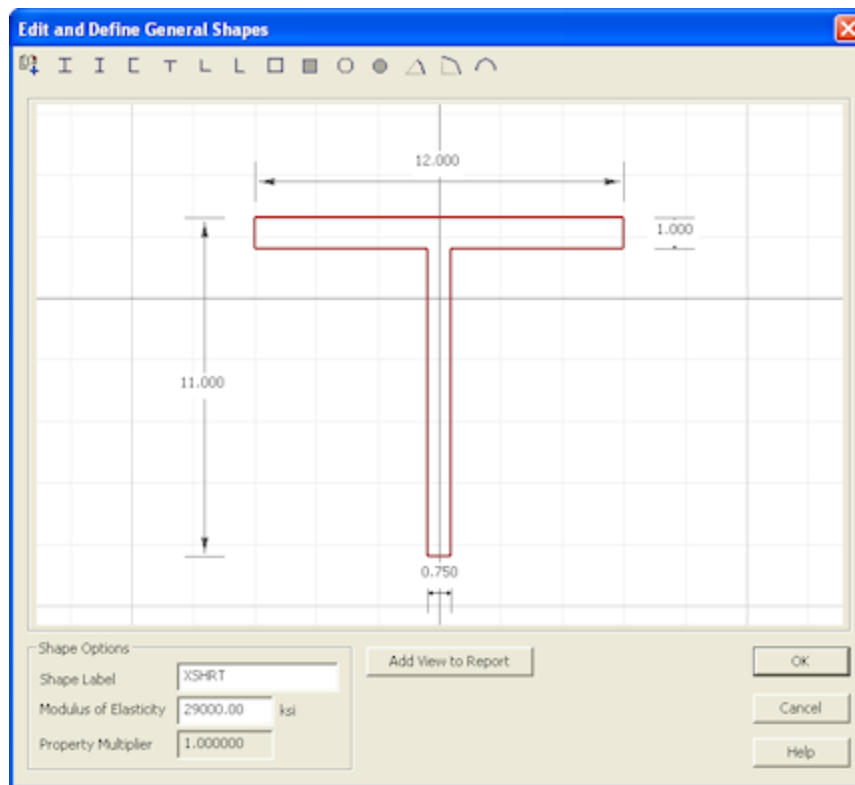

7. Next, double-click the **Solid Rectangular** shape from the **Basic Steel Shapes Library** to add it to your section.

8. Double click the edge of the **Solid Rectangular** shape to open the **Shape Editor**. Change the width to **8"** and the depth to **0.75"**. Click **OK** to close the editor.

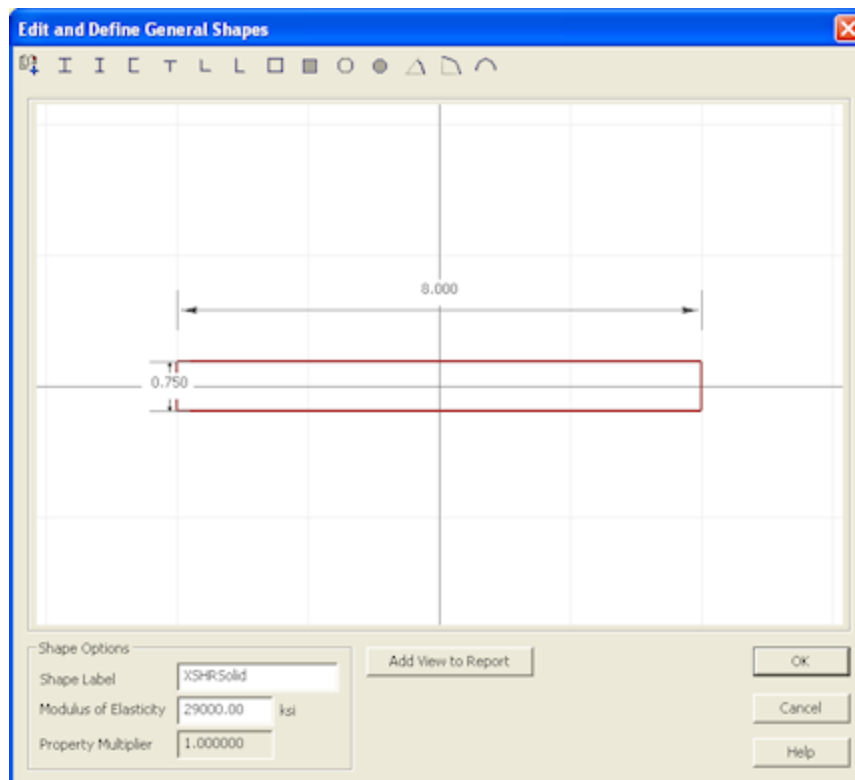

9. Next, you will move the shapes into the appropriate locations. In RISASection, you can always drag and drop sections manually, but for this example, you will use the **Alignment and Stack** tools to move the bottom flange.

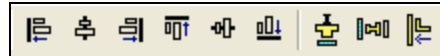

Start by selecting both shapes: click on **Select All** from the **Edit** menu.

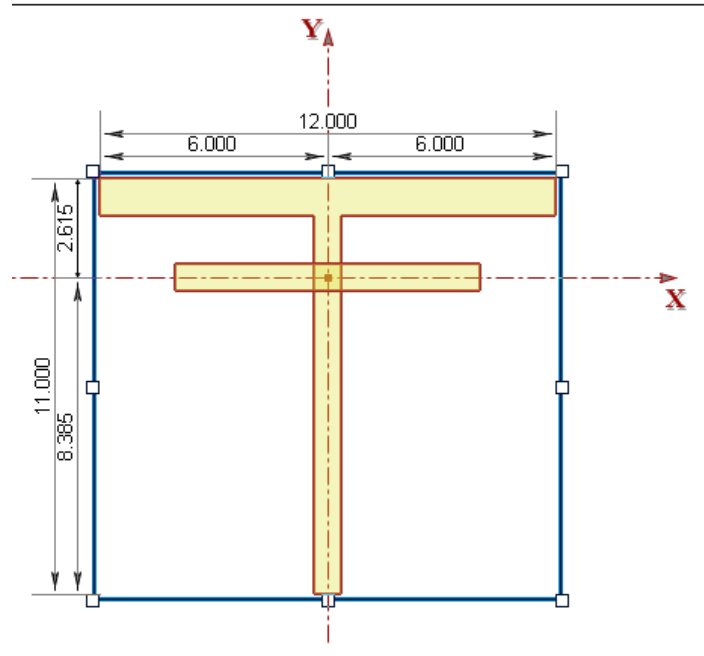

10. Click the **Align Bottom** button  first.

11. Next, click on the **Stack Shapes Vertically** button .

12. The next step is to assign the section the appropriate **Material** and **Shape Types** for integration with RISA-2D, RISA-3D, or RISAFloor.

In the **Section Information** window, select **Hot Rolled Steel** from the **Material Type** drop down menu. Then, select **Tapered WF** from the **Shape Type** menu.

Section Information	
File Name:	Tapered Wide Flange.nmsx
Section Name:	Tapered Wide Flange
Material Type:	Hot Rolled Steel
Shape Type:	Tapered WF

13. Click the **Merge** button  to merge together the two shapes into a single shape. This will ensure that you get the most accurate Torsional J calculation.

14. Click the **Solve** button  and the **Torsional J Solve** button  to update the results.

15. Finally, save the file by selecting **Save Section File** from the **File** menu. Continue with the next example to learn how to add multiple sections to one file.

Cap Channel Example

- Continuing from the previous example, you will now add a new section to the existing file. Click the **Add New Section** button  from the RISA Toolbar. This will automatically open a new section with a blank workspace.
- Under the **Shape Library**, click on **RISA HR Database**.

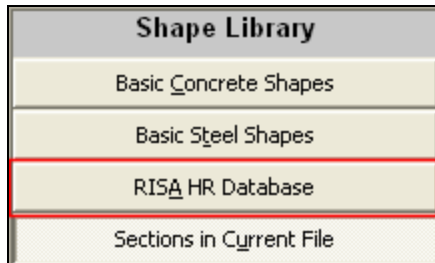

- Make sure that the **Database** selection (on the Window toolbar) is set to **AISC**.

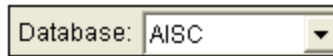

- In the database on the left, double-click **W14X30** in order to add it to your workspace. Since this is a shape taken directly from the program databases, the dimensions are all preset and so you do not need to modify anything.



- Next, click on the **Channel** tab  and double-click on the **C12X20.7** to add it to the section.

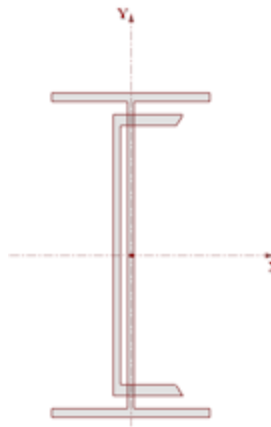

6. Click on the edge of the channel section to select it.

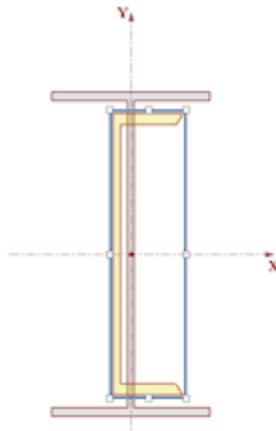

7. Click the **Rotate Right** button  to flip the channel 90 degrees.

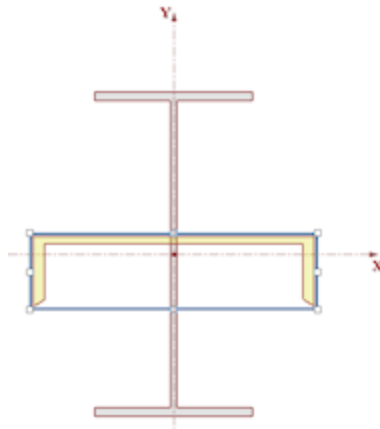

8. Click CTRL + A on your keyboard to select all shapes.

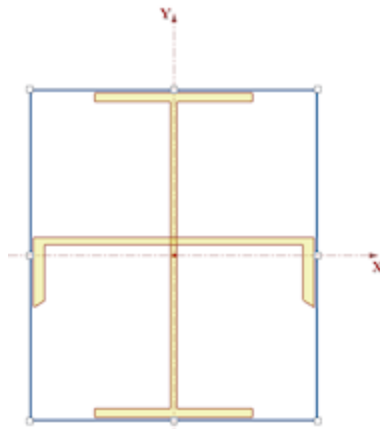

9. Select the **Align Center** button . Notice that this snaps the vertical axis of the wide flange to the centroid location of the channel. This is a bit off from the origin, so next, you will manually move these back.

10. Select **Shape Layout** from the **Section** menu. This will open the **Shape Layout Editor**.

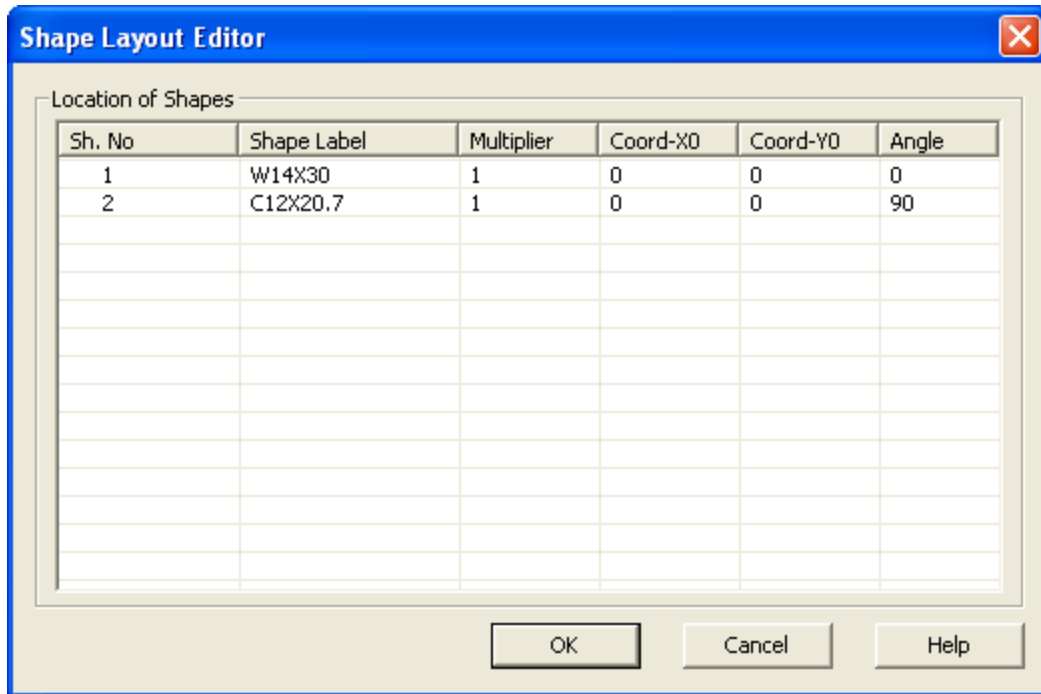

11. Make sure that the **Coord-Y0** value of both Shape Number 1 (**W14X30**) and Shape Number 2 (**C12x20.7**) to **0**. Click **OK** to close the dialog and make the changes.

12. Next, click on the channel, so just that one shape is selected. Click the **Parallel Align** button  on the Window Toolbar. Then, click on the inside edge of the channel web. Last, click on the upper edge of the top flange on the wide flange shape.

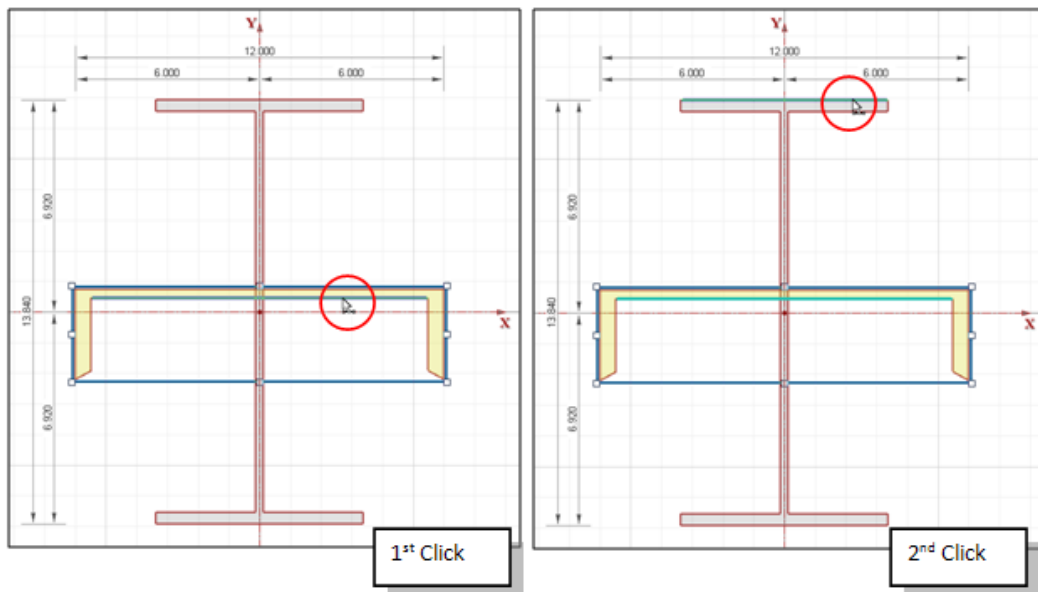

13. This will move the channel shape up so that it is now sitting on top of the wide flange.

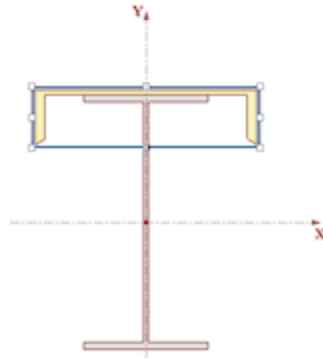

14. Finally, rename the section by clicking the **Rename Current Section** button  and then typing in “**Cap Channel**”.

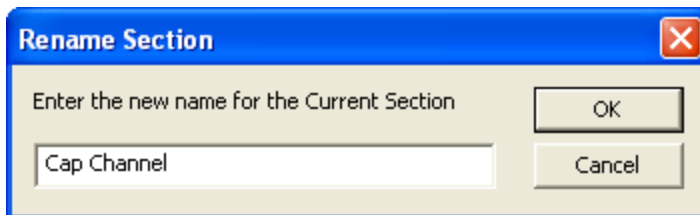

Since this shape does not fall within one of the predefined Hot Rolled Steel Shape Types, leave it designated as a **General Material, Arbitrary Shape**.

Section Information	
File Name:	Tapered Wide Flange.nmsx
Section Name:	Cap Channel
Material Type:	General
Shape Type:	Arbitrary

Multi-Material Shapes Examples

These example explore building shapes with multiple materials.

Composite Beam Example

Note - You may click the Undo button at any time to correct mistakes.

1. Start RISASection and open a new file.
2. Click **Close** to close the **Starting a Model** dialog.

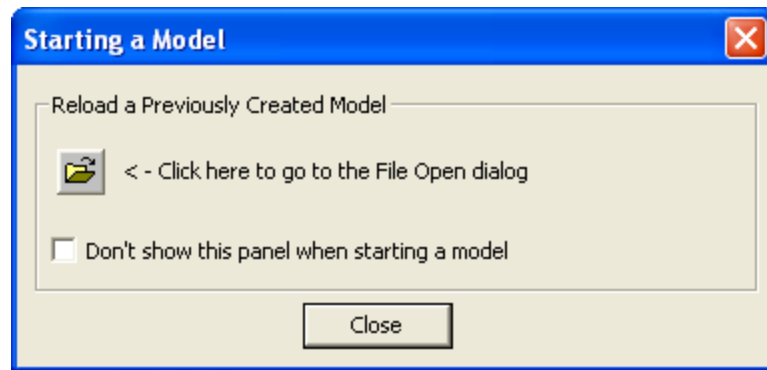

3. Click the **Rename Section** button  from the RISA Toolbar. Type in "**Composite Beam**" and click **OK**.

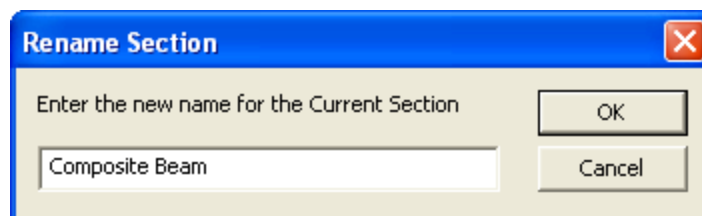

4. Under the **Shape Library**, click on **RISA HR Database**.

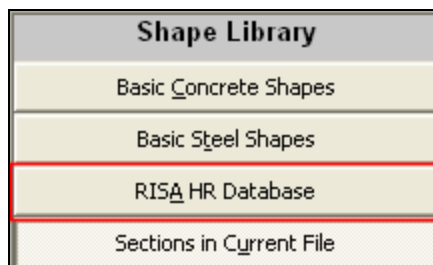

5. Make sure that the **Database** selection (on the Window toolbar) is set to **AISC**.

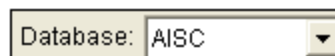

6. In the database on the left, double-click **W36X150** in order to add it to your workspace. Since this is a shape taken directly from the program databases, the dimensions are all preset and so you do not need to modify anything.



7. Next, click on the **Basic Concrete Shapes Library**. Double-click on the **Rectangular** shape to add it to your section.

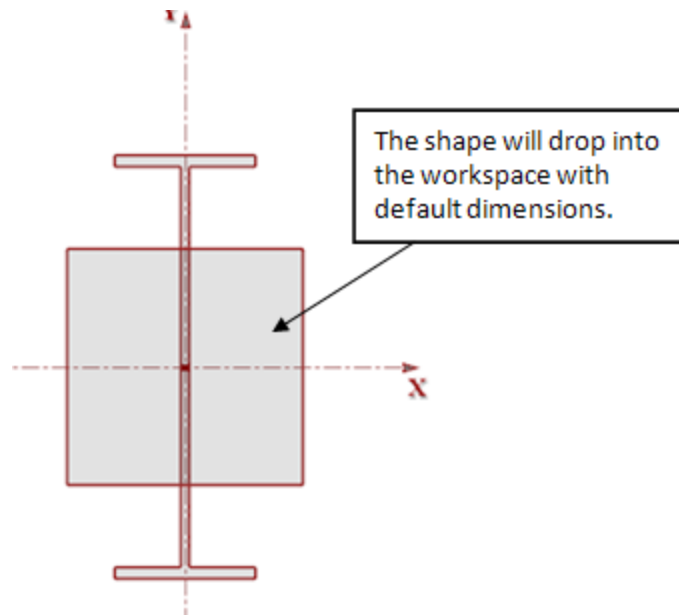

8. Double click the edge of the **Rectangular** shape to open the **Shape Editor**. Change the width to **36"** and the depth to **4"**. Click **OK** to close the editor.

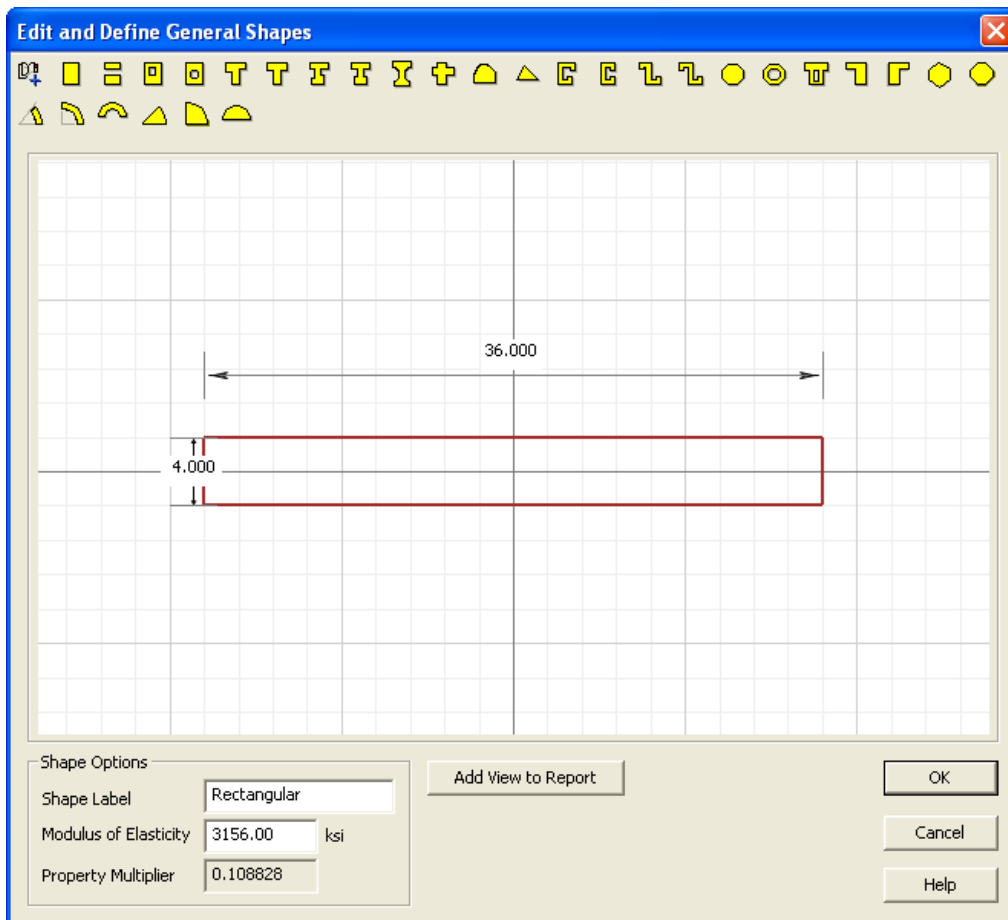

9. Next, you will move the shapes into the appropriate locations. In RISASection, you can always drag and drop sections manually or use the **Alignment and Stack** tools, but for this example you will manually adjust the centroid location in the **Shape Layout Editor**.

Select **Shape Layout** from the **Section** menu. This will open the **Shape Layout Editor**.

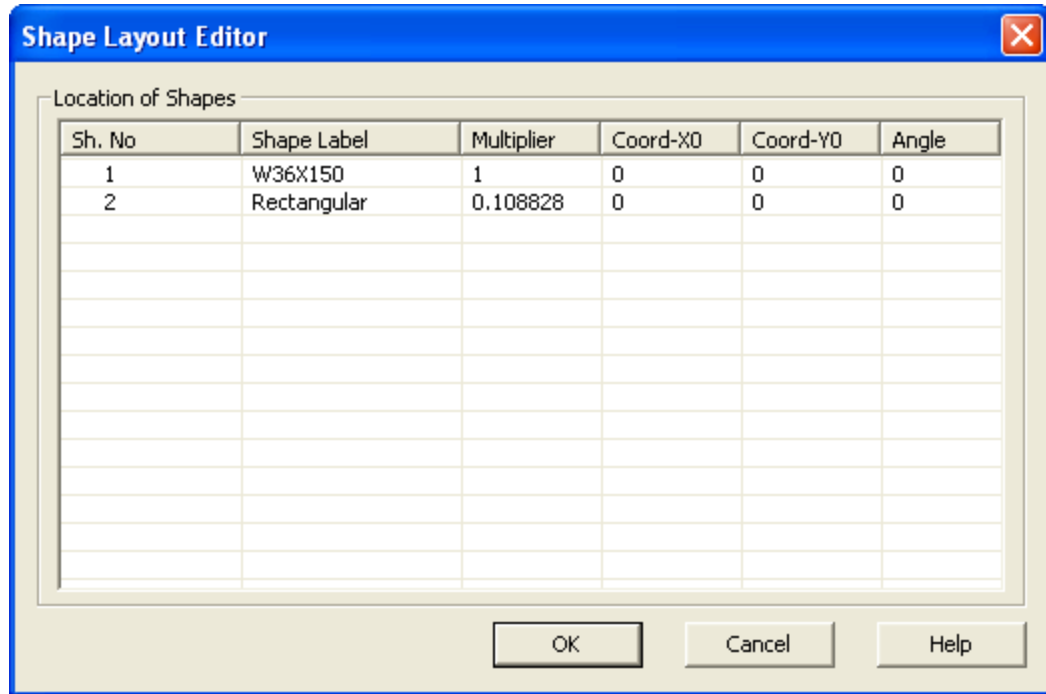

Notice that the Rectangular shape has a **Multiplier** of **0.108828**. This is because you selected it from the **Basic Concrete Shapes** library. This means that the Rectangular shape has a Modulus of Elasticity equal to $0.108828 \times 29000 \text{ ksi} = 3156 \text{ ksi}$.

10. Change the **Coord-Y0** value of Shape Number 2 (**Rectangular**) to **22.925**. Click **OK** to close the dialog and make the changes.

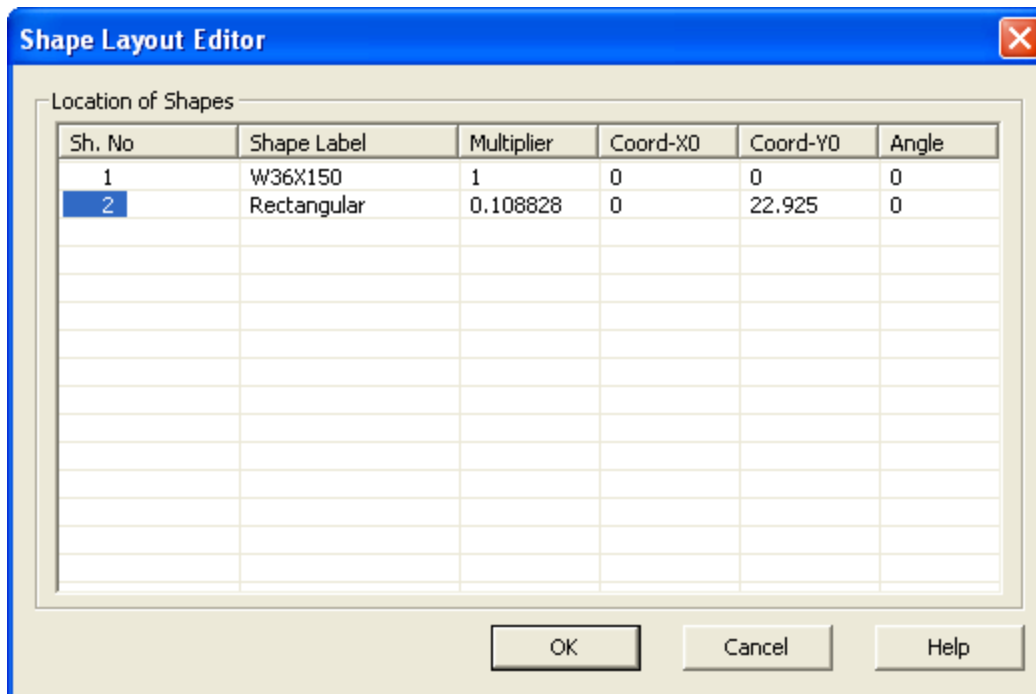

11. Click the **Reset View** button  to see the full section.

12. Next, define the **Material** and **Shape Type** in the **Section Information** window.

Since this shape does not fall within one of the predefined Hot Rolled Steel Shape Types, leave it designated as a **General Material, Arbitrary Shape**.

Section Information	
File Name:	Multi-Material Examples.nmsx
Section Name:	Composite Beam
Material Type:	General
Shape Type:	Arbitrary

13. Click the **Solve** button  and the **Torsional J Solve** button  to update the results.

14. Finally, save the file by selecting **Save Section File** from the **File** menu. Continue with the next example to add another section to the file.

Cracked Section Example

1. Continuing from the previous example, you will now add a new section to the existing file. Click the **Add New Section** button  from the RISA Toolbar. This will automatically open a new section with a blank workspace.

2. Under the **Shape Library**, click on **Basic Concrete Shapes**.

3. Double-click **Rectangular** to add it to your workspace.

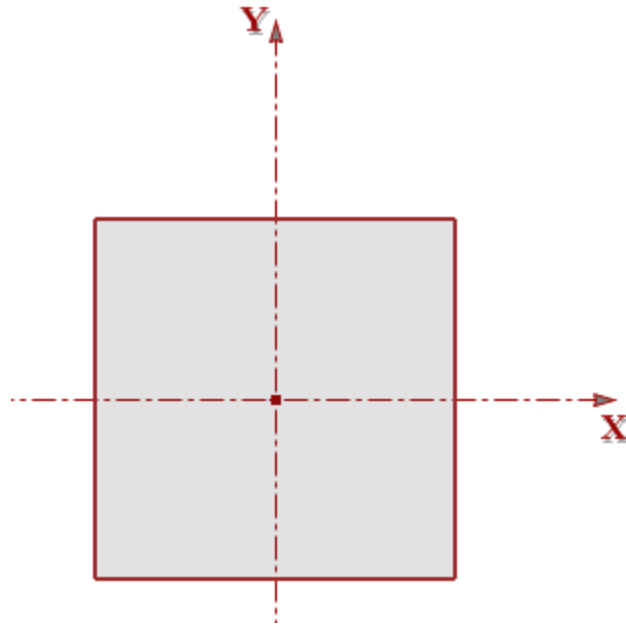

4. Double click the edge of the Rectangular shape to open the **Shape Editor**. Change the width to **10"** and the depth to **5.58"**. Click **OK** to close the editor.

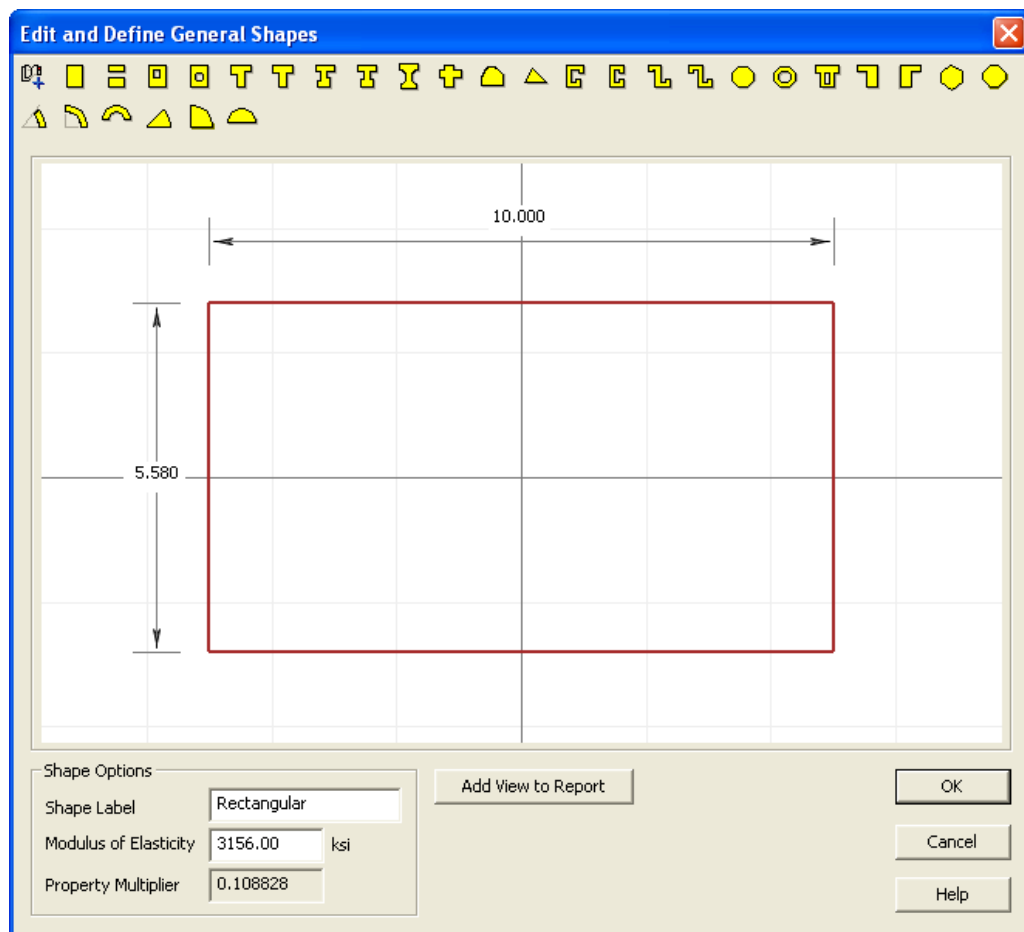

5. Next, click on the **Basic Steel Shapes** database under **Shape Library**.

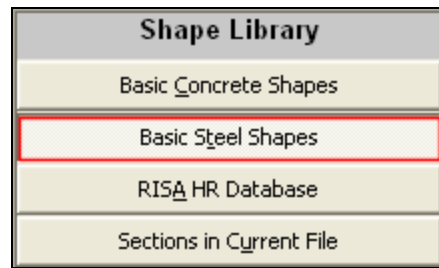

6. Double-click on the **Solid Bar** shape to add it to your section.
7. Double click the edge of the Solid Bar shape to open the **Shape Editor**. Change the diameter to **0.79"**. Click **OK** to close the editor.

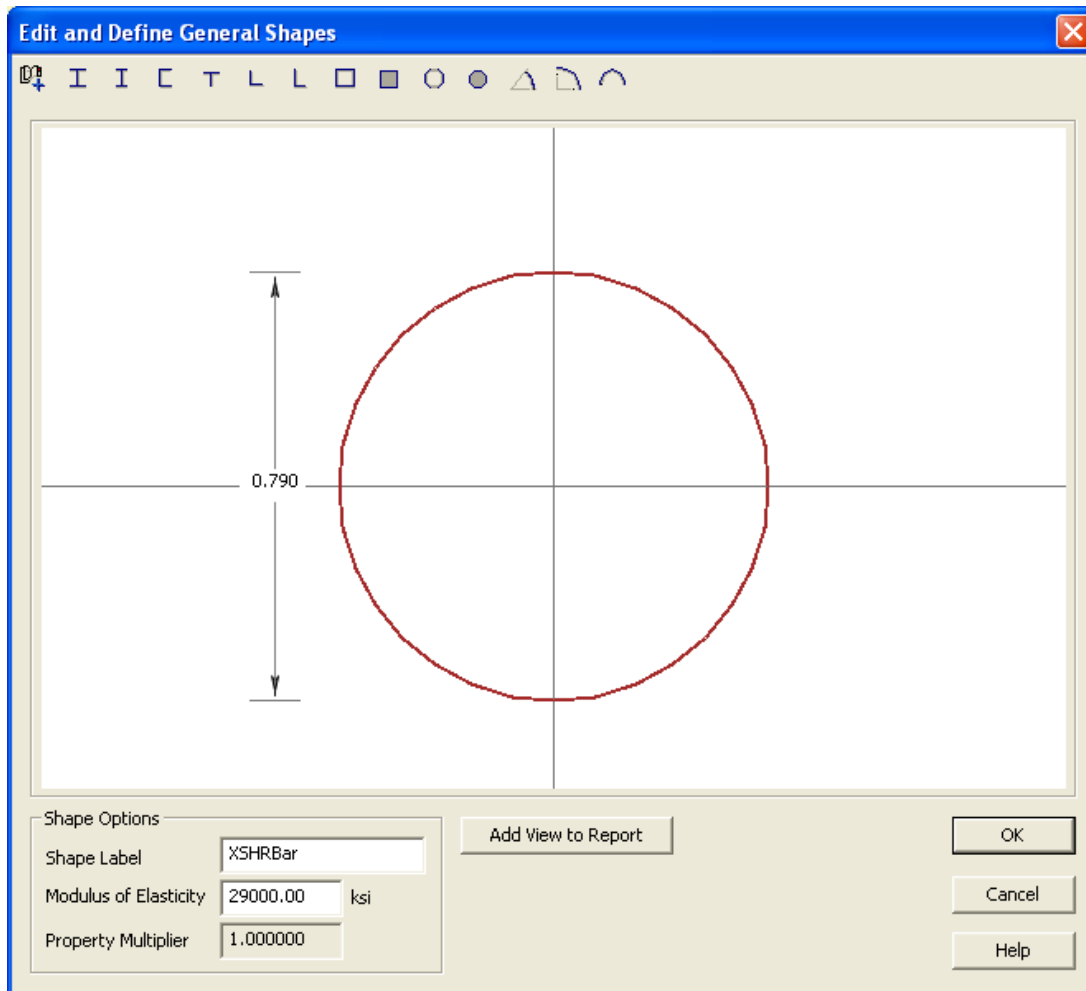

8. Next, move the Solid Bar down to the correct location. Open the **Shape Layout Editor**  and change the **Y0** coordinate of Shape No. 2 (**XSHRBar**) to **-17.21**.

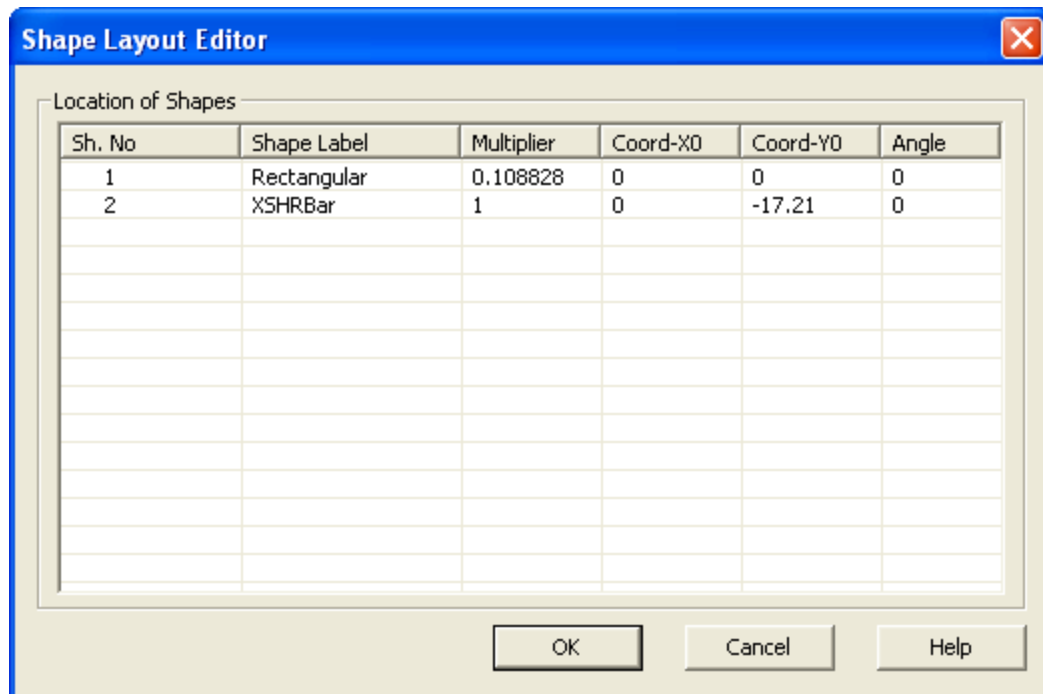

Click **OK** to close the editor.

9. Next, you will copy the Solid Bar shape twice to add the remaining shapes. Select the Solid Bar shape by clicking on its edge.

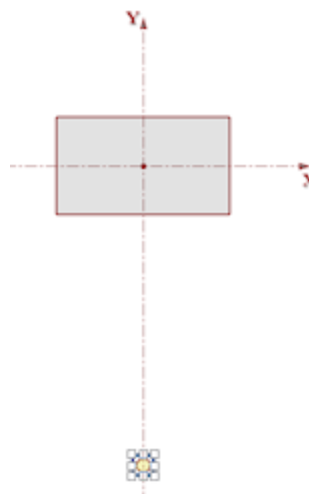

10. Use the right-click menu to first **Copy** the selection and then **Paste** it twice.

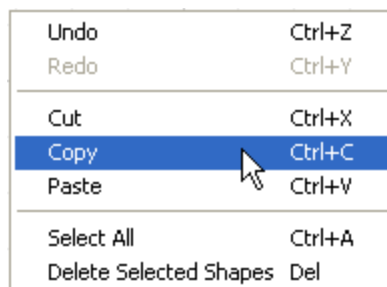

11. Reopen the **Shape Layout Editor** and change the coordinates of the two new bars to match the following:

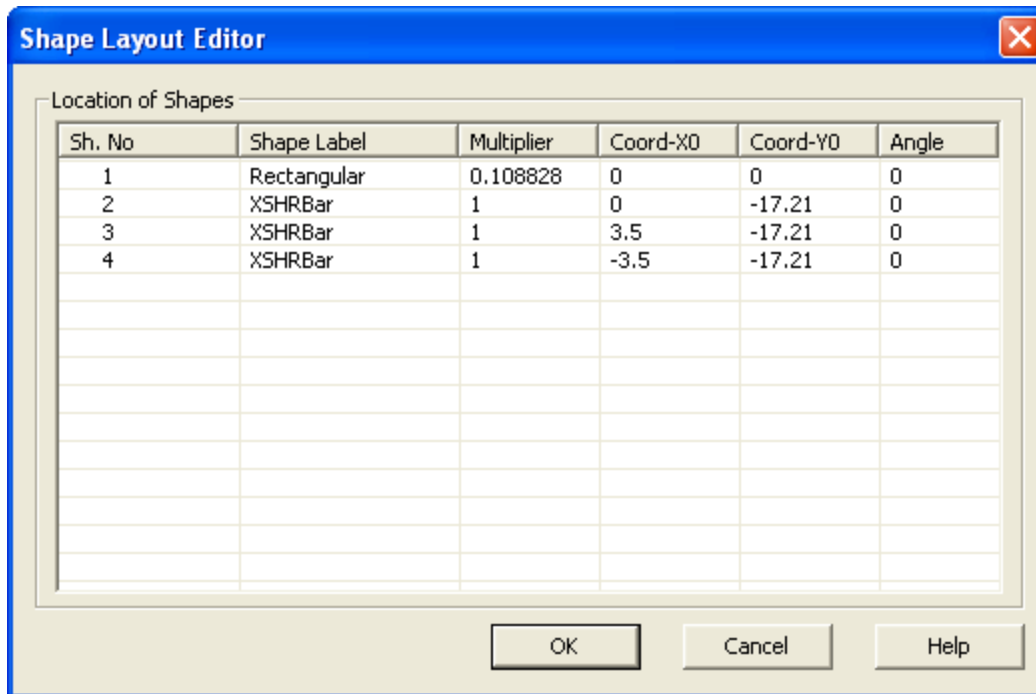

12. Finally, rename the section by typing “**Cracked Section**” into the **Section Name** entry in the **Section Information** window.

Section Information	
File Name:	Multi-Material Examples.nmsx
Section Name:	Cracked Section
Material Type:	General
Shape Type:	Arbitrary

Since this shape does not fall within one of the predefined Hot Rolled Steel Shape Types, leave it designated as a **General Material, Arbitrary Shape**.

13. Save the file by clicking on the **Save Section File** button  .

Technical Support

Technical support is an important part of the RISASection package. There is no charge for technical support for all licensed owners of the **current** version of RISASection. Technical support is very important to the staff at RISA. We want our users to be able to reach us when they are having difficulties with the program. However, this service is not to be used as a way to avoid learning the program or learning how to perform structural modeling in general.

Hours: 6AM to 5PM Pacific Standard Time, Monday through Friday

Before contacting technical support, you should typically do the following:

1. **Please search the Help File or General Reference Manual.** Most questions asked about RISASection are already answered in the Help File or General Reference Manual. Use the table of contents or index to find specific topics and appropriate sections. We go to great lengths to provide extensive written and on-line documentation for the program. We do this in order to help you understand the features and make them easier to use. Also be sure to go through the entire General Reference Manual when you first get the program.
2. If you have access to the Internet, you can visit our website at www.risa.com and check out our **Support** page for release notes, updates, downloads, and frequently asked questions. We list known issues and product updates that you can download. So, if you think the program is in error you should see if the problem is listed and make sure you have the latest release. The **FAQ (Frequently Asked Questions)** section may also address your question.
3. Make sure you understand the problem, and make sure your question is related to the program or structural modeling. Technical Support does not include free engineering consulting. RISA does provide a consulting service. If you are interested in inquiring about this service, please call RISA.
4. Take a few minutes to experiment with the problem to try to understand and solve it.

For all modeling support questions, please be prepared to send us your model input file via email or postal mail. We often will need to have your model in hand to debug a problem or answer your questions.

Email: support@risa.com: This method is the **best** way to send us a model you would like help with. Most email packages support the attachment of files. The input file you would send will have a .nmsx extension. Make sure you tell us your name, company name, serial number or Key ID, phone number, and give a decent problem description.

Phone Support:(949) 951-5815: Feel free to call, especially if you need a quick answer and your question is not model specific and therefore doesn't require us to look at your file.

Index

A

Add Current View to Report 44
Additional Calculated Properties 23
Additional Torsional Properties 21
Aligning and Stacking Shapes 16
Application Interface 4
Assumptions and Limitations 24
Auto 31

B

Base Modulus of Elasticity 42
Basic Steps 13
Build a Section 13
Built-up Sections 22
Built-Up Shapes Example 45

C

CAD Plane 38
CAD Vertical Axis 38
Calculated Properties 23
Calculation Methodology 21
Cap Channel Example 49
Closed Shapes 21
Color Notation 15
Colors 41
Composite Sections 22
Cracked Section Example 56
Cutting and Pasting Shapes 16

D

Database 9
Dragging Shapes 15

DXF Import 37
DXF Procedure 37
DXF Units 37

E

Editable Properties 30
Editing Shapes 15
Email (support) 61
Examples 45

G

General Options 39

H

Help 5
Hot Keys 6
How it Works 13

I

Import DXF Options 37
Important Assumption! 20
Interaction with RISA3-D and 2-D 33
Interface 4
Invalid DXF Shapes 38

L

Library 10
License Agreement 1

M

Manuals 1
Menus 4
Merge and Explode 16

Merge Tolerance 40
Minimum System Requirements 1
Moving and Editing Shapes 15
Multi-Material Shapes Examples 52

O

Options 5, 39

P

Phone (support) 61
Plastic Modulus 21
Polygon Method 21
Preparing Report 43
Previewing Current Report 44
Print Current Report 44
Printing 43
Project Information 4
Properties 12
Properties Window 12
Property Calculations 20
Property Multiplier 22

R

Rendered 11
Report Creation Wizard 43
Report Main Items 43
Report Section Items 44
Results 5
RISA-2D 33
RISA-3D 33
RISA Database 39
RISAFloor 33
Rotating Shapes 15

S

Saving 19

Section 5
Section Information 11
Section Properties 22
Section Property Options 42
Selecting Shapes 14
Shape Editor 16
Shape Layout Editor 17
Shape Library 10
Shape Type 20
Shortcut 6
Solving 19
Startup Checkboxes 40
Status Bar 9
Stiffness Defaults 42
Stretching Shapes 15

T

Tapered Wide Flange 45
Technical Support 61
Thin Walled Open Shapes 22
Title Bar 4
Toolbars 6
Torsion Constant J 21
Troubleshooting Integration 34
Tutorial 1

U

Units 39

V

View Options 41
Views 41

W

Workspace 10